

Condair CP3

Electrode Humidifiers



TECHNICAL DOCUMENTATION

Contents

1	Introduction	4	6	Operation	46
1.1	To the very beginning	4	6.1	Commissioning	46
1.2	Notes on the technical documentation	4	6.2	Notes on operation	47
2	For your safety	6	6.2.1	Function of the display and operating elements	47
3	Product Overview	8	6.2.2	Remote operating and fault indication	47
3.1	Models overview	8	6.2.3	Inspections during operation	48
3.2	Identification of the unit	9	6.2.4	Carrying out manual draining	48
3.3	Steam humidifier construction	10	6.3	Taking the unit out of operation	48
3.4	Functional description	11	6.4	Overview and operating of the menu	49
3.5	Humidification system overview	12	6.5	Interrogation functions	50
3.6	Overview unit interconnection	13	6.5.1	Interrogation of the operating information in the indication level	50
3.7	Options	14	6.5.2	Interrogation of unit information	51
3.7.1	Options overview	14	6.5.3	Interrogation of the malfunction list	52
3.7.2	Option details	15	6.6	Unit settings	53
3.8	Accessories	16	6.6.1	Launching the unit settings menu	53
3.8.1	Accessories overview	16	6.6.2	Selecting the dialogue language	53
3.8.2	Accessory details	17	6.6.3	Control settings	53
3.9	Standard delivery	18	6.6.4	Cylinder settings	55
3.10	Storing/Transportation/Packaging	18	6.6.5	Setting the capacity limitation	56
4	Notes for the planning engineer	19	6.6.6	Configuring the On/Off timer	57
4.1	Selecting the unit version	19	6.6.7	Activating/Deactivating fault current relay operation	57
4.1.1	Calculating the maximum required steam capacity	19	6.6.8	Setting the operation mode for multiple units	58
4.1.2	Selecting the unit	20	6.6.9	Water management settings	58
4.2	Selecting the options an accessories	20	6.6.10	Performing remote relay tests	59
4.3	Selecting the control system	21	6.6.11	Setting the date	59
5	Mounting and installation work	24	6.6.12	Setting the time	59
5.1	Important notes for mounting and installation work	24	6.6.13	Setting the display contrast	60
5.2	Installation overview	25	6.7	Modbus settings	60
5.3	Mounting the unit	26	7	Maintenance	61
5.3.1	Notes on locating the unit	26	7.1	Important notes on maintenance	61
5.3.2	Mounting the humidifier	28	7.2	Maintenance list	62
5.3.3	Inspecting the installed unit	29	7.3	Removing and installing parts for maintenance	63
5.4	Steam installation	30	7.3.1	Removal and installation of the steam cylinder	63
5.4.1	Overview steam installation	30	7.3.2	Disassembly and assembly of the cleanable steam cylinder type D...	65
5.4.2	Positioning and mounting of the steam distribution pipes	31	7.3.3	Removal and installation of the water cup and the water hoses	66
5.4.3	Installing the steam distributors	34	7.3.4	Removal and installation of the drain pump	67
5.4.4	Positioning and mounting of the fan unit	35	7.3.5	Removal and installation of the inlet valve	67
5.4.5	Installing the steam hose	36	7.4	Notes on cleaning the unit components	68
5.4.6	Installing the condensate hose	37	7.5	Notes on cleaning agents	69
5.4.7	Inspecting the steam installation	38	7.6	Resetting the maintenance indication	70
5.5	Water installation	39	8	Malfunctions	71
5.5.1	Overview water installation	39	8.1	Malfunction list	71
5.5.2	Notes on water installation	40	8.1.1	System faults	71
5.5.3	Inspecting the water installation	41	8.1.2	Unit faults	72
5.6	Electric installation	42	8.2	Notes on fault elimination	74
5.6.1	Wiring diagram Condair CP3 Basic/Pro	42	8.3	Resetting the error indication (red LED lights)	74
5.6.2	Wiring diagram Link Up systems	43	9	Taking out of service/Disposal	75
5.6.3	Fuses F3 for heating voltage supply	44	9.1	Taking out of service	75
5.6.4	Inserting the CP3 Card	45	9.2	Disposal/Recycling	75
5.6.5	Notes on electric installation	45	10	Product specifications	76
5.6.6	Inspecting the electrical installation	45	10.1	Technical data	76
			10.2	Unit dimensions	77

1 Introduction

1.1 To the very beginning

We thank you for having purchased the **steam humidifier Condair CP3**.

The steam humidifier Condair CP3 incorporates the latest technical advances and meets all recognized safety standards. Nevertheless, improper use of the Condair CP3 may result in danger to the user or third parties and/or impairment of material assets.

To ensure a safe, proper, and economical operation of the steam humidifier Condair CP3, please observe and comply with all information and safety instructions contained in the present technical documentation as well as the instructions given in the manuals for the components used in the humidification system.

If you have questions, which are not or insufficiently answered in this documentation, please contact your Condair supplier. They will be glad to assist you.

1.2 Notes on the technical documentation

Limitation

The subject of this technical documentation is the steam humidifier Condair CP3 in its versions "Basic" and "Pro". The various accessories (e.g. steam distributor, steam distribution system, etc.) are only described insofar as this is necessary for proper operation of the equipment. Further information on accessories can be obtained in the respective instructions.

This technical documentation is restricted to the **installation, commissioning, operation, servicing and trouble shooting** of the steam humidifier Condair CP3 and is meant for **well trained personnel being sufficiently qualified for their respective work**.

The technical documentation is supplemented by various separate items of documentation (spare parts list, manuals for accessories, etc.). Where necessary, appropriate cross-references are made to these publications in the technical documentation.

Symbols used in this manual

CAUTION!

The catchword "CAUTION" designates notes in this technical documentation that, if neglected, may cause **damage and/or malfunction of the unit or other material assets** and/or may lead to **injury to persons**.



WARNING!

The catchword "WARNING" used in conjunction with the general caution symbol designates safety and danger notes in this technical documentation that, if neglected, may lead to **severe injury or even lethal violation of persons**.

Safekeeping

Please safeguard this technical documentation in a safe place, where it can be immediately accessed. If the equipment changes hands, the documentation should be passed on to the new operator.

If the documentation gets mislaid, please contact your Condair supplier.

Language versions

This technical documentation is available in various languages. Please contact your Condair supplier for information.

Copyright protection

The present technical documentation is protected under the Copyright Act. Passing-on and reproduction of the manual (or part thereof) as well as exploitation and communication of the contents are prohibited without written permission by the manufacturer. Violation of copyright terms is subject to legal prosecution and arises liability for indemnification.

The manufacturer reserves the right to fully exploit commercial patent rights.

2 For your safety

General

Every person working with the Condair CP3 must have read and understood the Technical Documentation before carrying out any work.

Knowing and understanding the contents of the Technical Documentation is a basic requirement for protecting the personnel against any kind of danger, to prevent faulty operation, and to operate the unit safely and correctly.

All ideograms, signs and markings applied to the unit must be observed and kept in readable state.

Qualification of personnel

All actions described in the present Technical Documentation (installation, operation, maintenance, etc.) must be carried out only by **well trained and sufficiently qualified personnel authorised by the owner**.

For safety and warranty reasons any action beyond the scope of this manuals must be carried out only by qualified personnel authorised by the manufacturer.

It is assumed that all persons working with the Condair CP3 are familiar and comply with the appropriate regulations on work safety and the prevention of accidents.

Intended use

The steam humidifier Condair CP3 is intended exclusively for **air humidification via a steam distributor or a ventilation unit approved by the manufacturer within the specified operating conditions** (see chapter 10 "Product specifications"). Any other type of application without the express written consent of the manufacturer is considered as not conforming with the intended purpose and may lead to the Condair CP3 becoming dangerous.

Operation of the equipment in the intended manner requires **that all the information in these instructions is observed (in particular the safety instructions)**.

Danger that may arise from the unit

- The Condair CP3 is mains powered.

 WARNING!	<p>One may get in touch with live parts when the unit is open. Touching live parts may cause severe injury or danger to life.</p>
--	---

Prevention: Before carrying out any work set the Condair CP3 out of operation as described in chapter 6.3 (switch off the unit, disconnect it from the mains and stop the water supply) and secure the unit against inadvertent power-up.

- The Condair CP3 produces steam. When producing steam, the steam cylinder inside the humidifier gets very hot (up to 100 °C).

 WARNING!	<p>If the unit is opened immediately after having produced steam there is danger of burning when touching the steam cylinder.</p>
--	---

Prevention: Before carrying out any work set the Condair CP3 out of operation as described in chapter 6.3, then wait until the evaporation unit has cooled down sufficiently thus preventing danger of burning.

Behaviour in case of danger

If it is suspected that **safe operation is no longer possible**, then the Condair CP3 should immediately **be shut down and secured against accidental power-up according to chapter 6.3**. This can be the case under the following circumstances:

- if the Condair CP3 or its mains cable is damaged
- if the Condair CP3 is no longer operating correctly
- if connections and/or piping are not sealed

All persons working with the Condair CP3 must report any alterations to the unit that may affect safety to the owner without delay.

Prohibited modifications to the unit

No modifications must be undertaken on the Condair CP3 without the express written consent of the manufacturer.

For the replacement of defective components use exclusively **original accessories and spare parts** available from your Condair supplier.

3 Product Overview

3.1 Models overview

Steam air humidifiers Condair CP3 are available in the versions “**Basic**” and “**Pro**” with **different heating voltages** and **steam capacities ranging from 5 kg/h up to a max. of 180 kg/h.**

Heating voltage *	Max. steam capacity in kg/h	Graduation in kg/h	Model Condair CP3		Unit size / Number of units		
			Basic...	Pro...	Single unit small	Single unit large	Double unit large
400V3 (400V/3~/50...60Hz)	5...15	1	5...15	5...15	1		
	16...45	1	16...45	16...45		1	
	52	--	52	52			1
	60	--	60	60			1
	70	--	70	70			1
	80	--	80	80			1
	90	--	90	90			1
	105 **	--	--	105		1	1
	120 **	--	--	120		1	1
	135 **	--	--	135		1	1
	152 **	--	--	152			2
	160 **	--	--	160			2
180 **	--	--	180			2	
230V3 (230V/3~/50...60Hz)	5...15	1	5...15	5...15	1		
	16...30	1	16...30	16...30		1	
	44	--	44	44			1
	50	--	50	50			1
	60	--	60	60			1
	75 **	--	--	75		1	1
	90 **	--	--	90		1	1
	100 **	--	--	100			2
120 **	--	--	120			2	
230V1 (230V/1~/50...60Hz)	5...8	1	5...8	5...8	1		

* Other heating voltages on request

** Link Up systems

Key model designation

Example:

Condair CP3 Pro 45 400V3

Unit Version: _____

Pro
Basic

Maximum steam capacity in kg/h: _____

Heating voltage: _____

400V/3~/50...60Hz: **400V3**

230V/3~/50...60Hz: **230V3**

230V/1~/50...60Hz: **230V1**

3.2 Identification of the unit

The identification of the unit is found on the type plate (for the location of the type plate see unit overview):

	Type designation	Total steam capacity in kg/h	Serial number (7 digits)	Month/Year
Unit voltage (heating voltage)	Walter Meier (Climate International) Ltd. 8808 Pfäffikon			
	Condair CP3 Pro 45		XXXXXXX	11.06
	400V 3~ / 50...60Hz		33.8 kW	
Maximum steam capacity per unit	Dampf/Steam/Vapeur = 45.0 kg/h		Wechselstrom AC	
Admissible water supply pressure	Wasser/Water/Eau = 1...10 bar		Main Unit / Modul A	
Operation note				
Unit designation	Made in Switzerland			

3.3 Steam humidifier construction

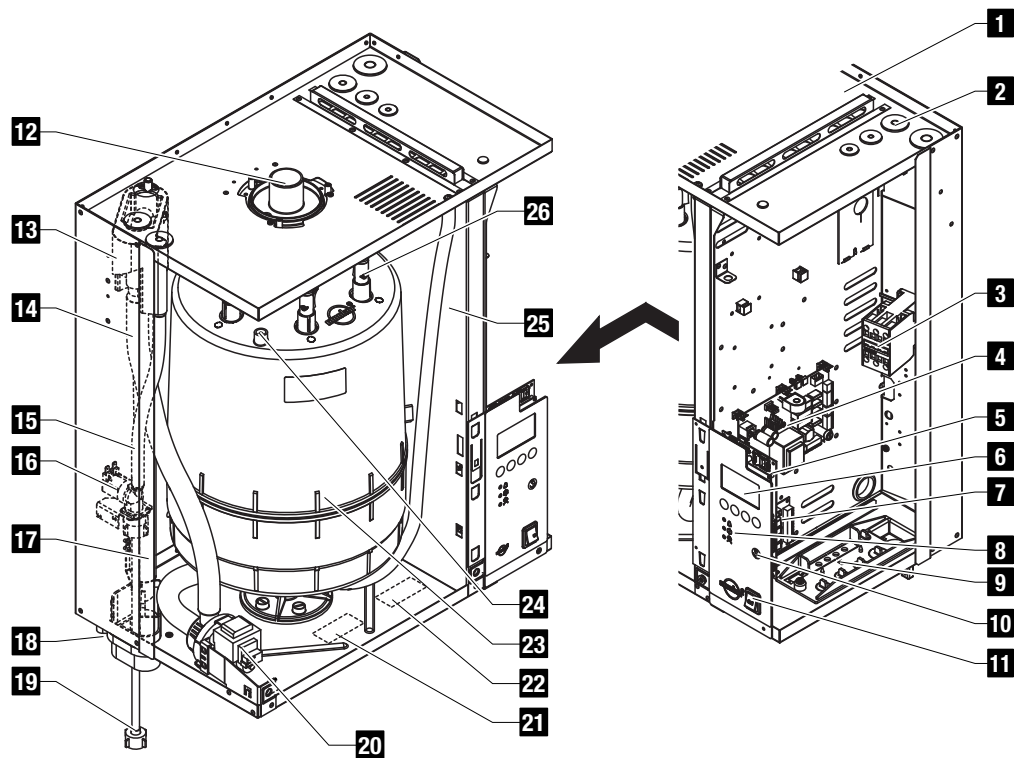

The illustration above shows the large unit

- | | | | |
|----|---|----|--------------------------------|
| 1 | Housing (small, large) | 14 | Filling hose |
| 2 | Cable openings, top side | 15 | Water supply hose |
| 3 | Main contactor | 16 | Inlet valve |
| 4 | Power board | 17 | Overflow hose |
| 5 | Control board with CP3 Card | 18 | Drain connection (not visible) |
| 6 | Display and control unit | 19 | Water supply pipe |
| 7 | Remote operating and fault indication board | 20 | Drain pump |
| 8 | Operation status indicators | 21 | Type plate |
| 9 | Cable openings, bottom side | 22 | Data plate CP3 Card |
| 10 | Drain key | 23 | Steam cylinder |
| 11 | Unit switch | 24 | Level sensor |
| 12 | Steam outlet | 25 | Auxiliary drain hose |
| 13 | Water cup | 26 | Electrode plug |

3.4 Functional description

The steam humidifier Condair CP3 is a pressureless steam generator that utilizes an electrode heating. The steam humidifier Condair CP3 is designed for air humidification via a steam distributor (steam distribution pipe, ventilation unit or steam distribution system OptiSorp).

Steam generation

Any time steam is requested, the electrodes are supplied with voltage via main contactor. Simultaneously, the inlet valve opens and water enters the steam cylinder from the bottom via water cup and supply line. As soon as the electrodes come in contact with the water, current begins to flow between the electrodes, eventually heating and evaporating the water. The more the electrode surface is exposed to water, the higher is the current consumption and thus the steam capacity.

Upon reaching the requested steam capacity, the inlet valve closes. If the steam generation decreases below a certain percentage of the required capacity, due to lowering of the water level (e.g. because of the evaporation process or drainage), the inlet valve opens until the required capacity is available again.

If the required steam capacity is lower than the actual output, the inlet valve is closed until the desired capacity is achieved by lowering of the water level (evaporation process).

Level monitoring

A sensor provided in the steam cylinder cover detects when the water level gets too high. The moment the sensor comes in contact with water, the inlet valve closes.

Drainage

As a result of the evaporation process, the conductivity of the water increases due to an escalating mineral concentration. Eventually, an inadmissibly high current consumption would take place if this concentration process were permitted to continue. To prevent this concentration from reaching a value, unsuitably high for the operation, a certain amount of water is periodically drained from the cylinder and replaced by fresh water.

Control

The steam production can be controlled steplessly via the internal or an external continuous controller or with an On/Off control via an external humidistat.

3.5 Humidification system overview

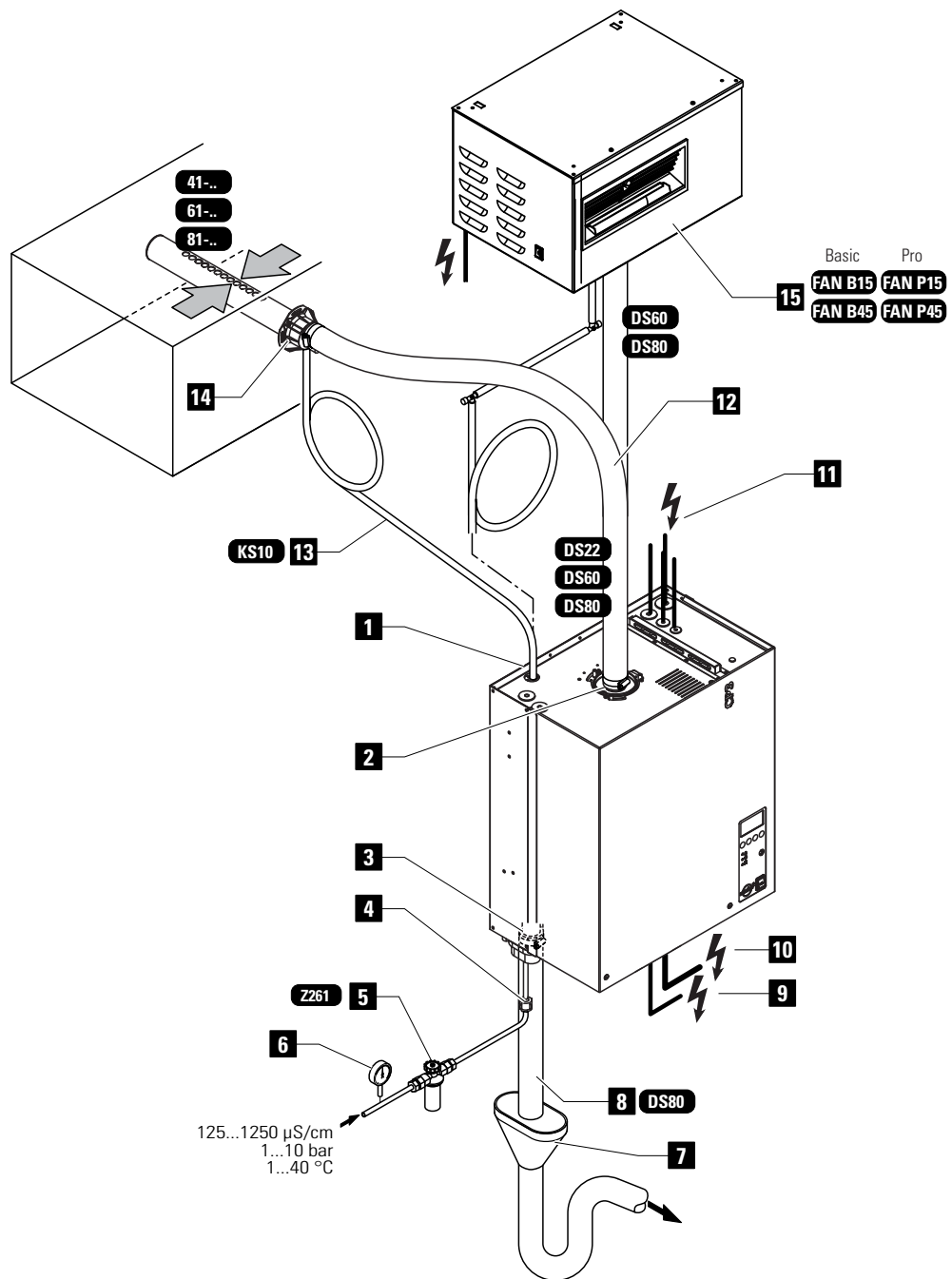

- | | | | |
|---|--------------------------------------|----|---|
| 1 | Steam humidifier | 9 | Control voltage supply |
| 2 | Steam connection | 10 | Heating voltage supply |
| 3 | Water drain connection | 11 | Cable openings |
| 4 | Water supply connection | 12 | Steam hose (accessory "DS..") |
| 5 | Filter valve (accessory "Z261") | 13 | Condensate hose (accessory "KS10") |
| 6 | Manometer (installation recommended) | 14 | Steam distribution pipe (accessory "41-.."/"61-.."/"81-..") |
| 7 | Funnel with siphon (building side) | 15 | Ventilation unit (accessory "FAN...") |
| 8 | Water drain hose (accessory "DS80") | | |

3.6 Overview unit interconnection

Single unit

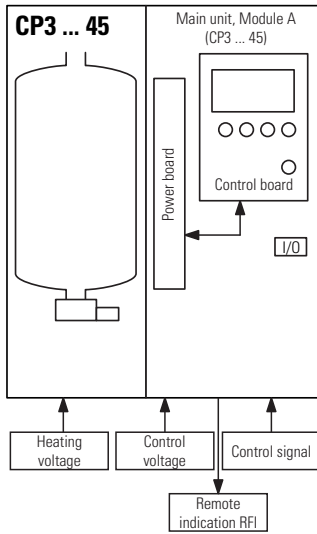

Double unit

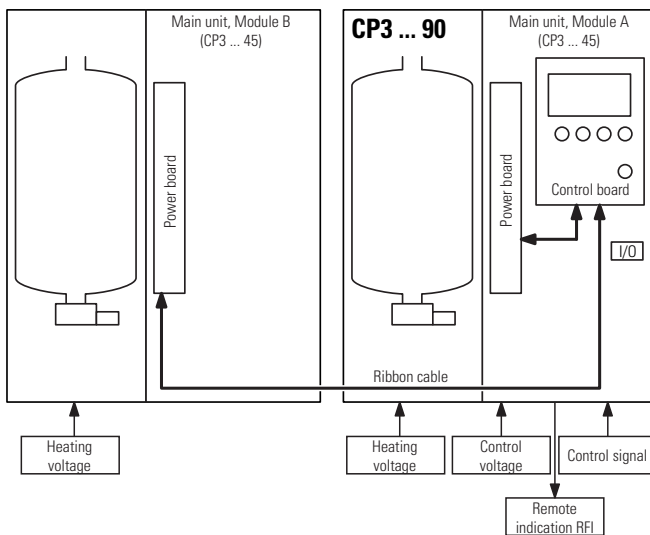

Double unit + single or double unit (Link Up system, Pro version only)

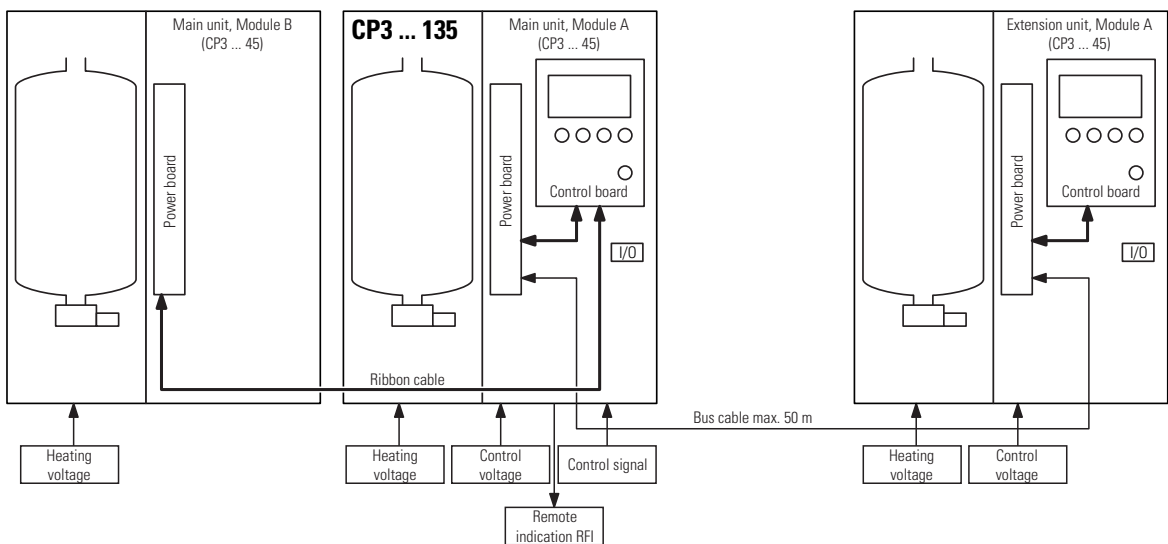

3.7 Options

3.7.1 Options overview

		Condair CP3 Basic... / Condair CP3 Pro...						
		230V1	5...8					
		400V3	5...8	9...15	16...45	52/60/70/80/90	105/120/135	152/160/180
		230V3	5...8	9...15	16...30	44/50/60	75/90	100/120
D...	Cleanable steam cylinder Cleanable steam cylinder as an alternative to the disposable steam cylinder built in as standard (see also chapter 3.7.2).	P/B	1x D3..	1x D4..	1x D6..	2x D6..	3x D6..	4x D6..
RFI	Remote operating and fault indication PCB with relay contacts for the connection of remote displays for "Operation", "Steam", "Fault" and "Service".	B *	1x RFI	1x RFI	1x RFI	1x RFI	1x RFI	1x RFI
OPS	Overpressure set Kit for mounting the water cup to the unit cover when operating the steam humidifiers in systems with a duct air pressure of up to 10 kPa.	P/B	1x OPS	1x OPS	1x OPS	2x OPS	3x OPS	4x OPS
THV	Terminals heating voltage Separate terminals for systems where direct connection of heating voltage to main contactor (standard version) is not permitted by local regulations.	B *	1x M-THV	1x M-THV	1x L-THV	2x L-THV	3x L-THV	4x L-THV
PG	Cable gland	P/B	1x PG	1x PG	1x PG	2x PG	3x PG	4x PG
INOX	Unit front cover made of stainless steel	P/B	1x M-INOX	1x M-INOX	1x L-INOX	2x L-INOX	3x L-INOX	4x L-INOX
SC..	Steam hose connector	B *	1x SC22	1x SC60	1x SC80	2x SC80	3x SC80	4x SC80
SCCT..	Steam hose connector with condensate trap	B	1x SCCT22	1x SCCT60	1x SCCT80	2x SCCT80	3x SCCT80	4x SCCT80
CT	Condensate trap	P/B	1x CT	1x CT	1x CT	2x CT	3x CT	4x CT
MP	Mounting profile	P/B	1x MP	1x MP	1x MP	2x MP	3x MP	4x MP
CVI	Internal control voltage	P/B	1x M-CVI	1x M-CVI	1x L-CVI	1x L-CVI **	2x L-CVI	2x L-CVI
TRAFO	Transformer (400V/230V)	P/B	1x M-Trafo	1x M-Trafo	1x L-Trafo	1x L-Trafo **	2x L-Trafo	2x L-Trafo

B Unit version Basic

P Unit version Pro

***** Standard for unit version Pro

****** Unit version Basic requires additionally option THV for unit module B

3.7.2 Option details

Steam cylinder

The steam humidifier is available with **two different types** of steam cylinders:

- **Exchangeable steam cylinder type A... (standard version)**
- **Cleanable steam cylinder type D... (option)**

The following tables present an overview of the steam cylinders used in the different models.

Condair CP3...400V3	5...8	9...15	16...25	26...45	52/60/70/80/90	105/120/135	152/160/180
For water conductivity from 125 to 1250 $\mu\text{S}/\text{cm}$							
Exchangeable steam cylinder	1xA363	1xA464	1xA674	1xA664	2xA664	3xA664	4xA664
Cleanable steam cylinder	1xD363	1xD464	1xD674	1xD664	2xD664	3xD664	4xD664
For low water conductivity							
Exchangeable steam cylinder	1xA343	1xA444	1xA654	1xA654	2xA654	3xA654	4xA654
Cleanable steam cylinder	1xD343	1xD444	1xD654	1xD654	2xD654	3xD654	4xD654

Condair CP3...230V3	5...8	9...15	16...21	22...30	44/50/60	75/90	100/120
For water conductivity from 125 to 1250 $\mu\text{S}/\text{cm}$							
Exchangeable steam cylinder	1xA343	1xA444	1xA654	1xA644	2xA644	3xA644	4xA644
Cleanable steam cylinder	1xD343	1xD444	1xD654	1xD674	2xD674	3xD674	4xD674

Condair CP3...230V1	5...8
For water conductivity from 125 to 1250 $\mu\text{S}/\text{cm}$	
Exchangeable steam cylinder	1xA342
Cleanable steam cylinder	1xD342

If you have questions regarding the steam cylinders please contact your Condair representative.

3.8 Accessories

3.8.1 Accessories overview

Accessories for water installation

		Condair CP3 Basic... / Condair CP3 Pro...					
	230V1	5...8					
	400V3	5...8	9...15	16...45	52/60/70/80/90	105/120/135	152/160/180
	230V3	5...8	9...15	16...30	44/50/60	75/90	100/120
Filter valve		Z261 (1 pcs. per system)					

Accessories for steam installation

		Condair CP3 Basic... / Condair CP3 Pro...					
	230V1	5...8					
	400V3	5...8	9...15	16...45	52/60/70/80/90	105/120/135	152/160/180
	230V3	5...8	9...15	16...30	44/50/60	75/90	100/120
Steam distribution pipe (Details see chapter 3.8.2)		1x 41-...	1x 61-...	1x 81-...	2x 81-...	3x 81-...	4x 81-...
Steam distribution system OptiSorp (Details see chapter 3.8.2)		—	System 1		System 2	System 3	System 4
Fan unit (Details see chapter 3.8.2)	Basic	1x FAN B15		1x FAN B45	2x FAN B45	3x FAN B45	4x FAN B45
	Pro	1x FAN P15		1x FAN P45	2x FAN P45	3x FAN P45	4x FAN P45
Steam hose / meter		1x DS22	1x DS60	1x DS80	2x DS80	3x DS80	4x DS80
Condensate hose / meter		1x KS10			2x KS10	3x KS10	4x KS10

Accessories for humidity control

		Condair CP3 Basic... / Condair CP3 Pro...					
	230V1	5...8					
	400V3	5...8	9...15	16...45	52/60/70/80/90	105/120/135	152/160/180
	230V3	5...8	9...15	16...30	44/50/60	75/90	100/120
Humidity sensor for duct installation		EGH110 (1 pcs. per system)					
Humidity sensor for room installation		EGH130 (1 pcs. per system)					
Duct humidistat		HBC (1 pcs. per system)					
Room humidistat		HSC (1 pcs. per system)					

3.8.2 Accessory details

3.8.2.1 Steam distribution pipe 41-.../61-.../81-...

The steam distribution pipes are selected on the basis of the **duct width** (for horizontal installation) or the **duct height** (for vertical installation) and the **capacity of the steam humidifier**.

Important! Always select the longest possible steam distribution pipe (optimum humidification distance).

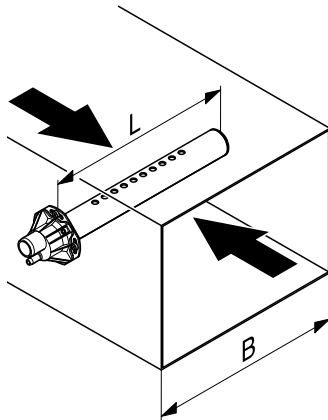

Steam distribution pipes for Condair CP3 ¹⁾			Length (L) steam distribution pipe in mm ²⁾	Duct width (B) in mm
Type 41-..	Type 61-..	Type 81-..		
41-200			200	210...400
41-350	61-350	81-350 ³⁾	350	400...600
41-500	61-500	81-500 ³⁾	500	550...750
41-650	61-650	81-650	650	700...900
41-800	61-800	81-800	800	900...1100
41-1000	61-1000	81-1000	1000	1100...1300
41-1200	61-1200	81-1200	1200	1300...1600
	61-1500	81-1500	1500	1600...2000
	61-1800	81-1800	1800	2000.2400
	61-2000	81-2000	2000	2200...2600
		81-2300	2300	2500...2900
		81-2500	2500	2700...3100

¹⁾ Material: CrNi steel

³⁾ up to max. 30 kg/h steam capacity

²⁾ special length on request

Note: If the humidification distance (see chapter 5.4.2) has to be reduced for technical reasons, the amount of steam per basic unit must be divided between **two steam distribution pipes** or the **steam distribution system OptiSorp** must be used. If this is the case, contact your Condair supplier.

3.8.2.2 OptiSorp steam distribution system

The OptiSorp steam distribution system is used in ventilation ducts with a short humidification distance (for the calculation of the humidification distance refer to chapter 5.4.2). When ordering an OptiSorp system the duct dimension must be specified. Please consult the data in the following table.

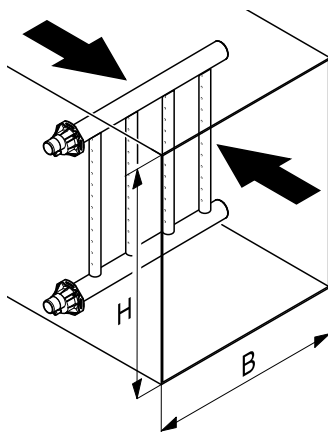

OptiSorp	Number of steam connectors	Max. steam capacity in kg/h ¹⁾	Duct dimensions	
			Width in mm	Height in mm
System 1	1	45 (30)	450-2700	450-1650
System 2	2	90 (60)	450-2700	450-2200
System 3	3	135 (90)	450-2700	800-3200
System 4	4	180 (120)	450-2700	800-3200

¹⁾ For duct widths <600 mm the values in brackets apply

3.8.2.3 Fan unit

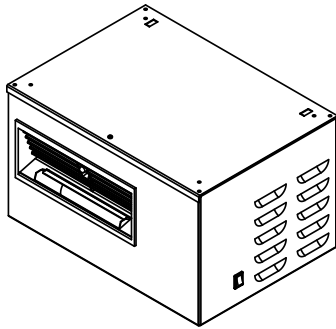

The fan units – in combination with the steam humidifiers Condair CP3 – are used for the direct room humidification. They are mounted **separately above the unit** to the wall.

The type of fan unit and the amount required is dependent on the steam capacity and on the type of the basic unit(s) and can be gathered from the table in chapter 3.8.1.

Note: Further information on the Condair FAN can be found in the separate Technical Documentation supplied with the Condair FAN.

The fan units are delivered with:

- Installation accessories for wall mounting including steam hose and steam hose connector with condensate trap “SCCT” (Basic version) or condensate trap “CT” (Pro version)
- Technical Documentation Condair FAN

3.9 Standard delivery

The standard delivery includes:

- Steam humidifier Condair CP3 equipped with the options ordered according to chapter 3.7, fixing set and Technical Documentation (this document), packaged in cardboard box
 - Unit small (WxHxD): 450 mm x 620 mm x 280 mm, shipping weight: 26 kg
 - Unit large (WxHxD): 559 mm x 667 mm x 350 mm, shipping weight: 31 kg
- Ordered accessories with operating instructions according chapter 3.8, packed separately
- Spare parts list

3.10 Storing/Transportation/Packaging

Storing

Store the unit in a protected area meeting the following requirements:

- Room temperature: 1 ... 40 °C
- Room humidity: 10 ... 75 %rh

Transportation

For optimum protection always transport the unit in the original packaging.

The weight of the small and the large unit is more than 20 kg (weight without packaging: small unit 23 kg, large unit 28 kg). Therefore, always transport the unit with the help of another person or use a forklift or a crane. Always place the unit on its back side.

Packaging

Keep the original packaging of the Condair CP3 for later use.

In case you wish to dispose of the packaging, observe the local regulations on waste disposal. Never dispose of the packaging to the environment.

4 Notes for the planning engineer

4.1 Selecting the unit version

To select the unit version the following planning steps are required:

1. Calculating the required maximum steam capacity according chapter 4.1.1
2. Selecting the unit version from the table in chapter 4.1.2

4.1.1 Calculating the maximum required steam capacity

The maximum required steam capacity must be calculated based on one of the following formulas:

$$m_D = \frac{V \cdot \rho}{1000} \cdot (x_2 - x_1)$$

or

$$m_D = \frac{V}{1000 \cdot \varepsilon} \cdot (x_2 - x_1)$$

m_D : maximum steam demand in **kg/h**

V : volume of supply air portion per hour in **m³/h** (for indirect room humidification) or room volume to be humidified per hour in **m³/h** (for direct room humidification)

ρ : specific gravity of air in **kg/m³**

ε : specific volume of air in **m³/kg**

x_2 : desired absolute room air humidity in **g/kg**

x_1 : minimum absolute supply air humidity in **g/kg**

The values for ρ , ε , x_2 and x_1 can be gathered from the **h,x-diagram** or the **Carrier-Diagram** for moist air respectively.

Important notes:

- The required maximum steam capacity depends on the specific application and the installation. The calculated steam capacity based on the above formulas, the h,x diagram and the condition of the air to be humidified does not consider any steam loss (e.g. due to condensation in the steam hoses and the steam distributors), any heat loss of the unit as well as any absorption or release of humidity of materials located in the room being humidified. In addition, the calculated steam capacity does not consider any losses caused by the draining rate depending on the water quality as well as any losses occur if the steam humidifier is operated on a mains circuit with a ground fault circuit interrupter. The total amount of losses depends on the entire system and must be taken into consideration when calculating the required steam capacity. If you have any questions regarding the calculation of the steam capacity please contact your Condair supplier.
- For systems where the max. required steam capacity varies extensively (e.g. for test facilities or for systems with variable air volume flow, etc.), please contact your Condair supplier.

4.1.2 Selecting the unit

Condair CP3 Pro 45 400V3

Heating voltage *	Max. steam capacity in kg/h	Graduation in kg/h	Model Condair CP3		Unit size / Number of units		
			Basic...	Pro...	Single unit small	Single unit large	Double unit large
400V3 (400V/3~/50...60Hz)	5...15	1	5...15	5...15	1		
	16...45	1	16...45	16...45		1	
	52	--	52	52			1
	60	--	60	60			1
	70	--	70	70			1
	80	--	80	80			1
	90	--	90	90			1
	105 **	--	--	105		1	1
	120 **	--	--	120		1	1
	135 **	--	--	135		1	1
	152 **	--	--	152			2
	160 **	--	--	160			2
180 **	--	--	180			2	
230V3 (230V/3~/50...60Hz)	5...15	1	5...15	5...15	1		
	16...30	1	16...30	16...30		1	
	44	--	44	44			1
	50	--	50	50			1
	60	--	60	60			1
	75 **	--	--	75		1	1
	90 **	--	--	90		1	1
	100 **	--	--	100			2
120 **	--	--	120			2	
230V1 (230V/1~/50...60Hz)	5...8	1	5...8	5...8	1		

* Other heating voltages on request

** Link Up systems

4.2 Selecting the options an accessories

For selecting the options and accessories see chapter 3.7 and 3.8.

4.3 Selecting the control system

The various control systems

– System 1: Room humidity control

System 1 is suited for **direct room humidification** and **air conditioning systems with mainly recirculated air**. The humidity sensor or humidistat respectively is preferably located in the room itself or in the exhaust air duct.

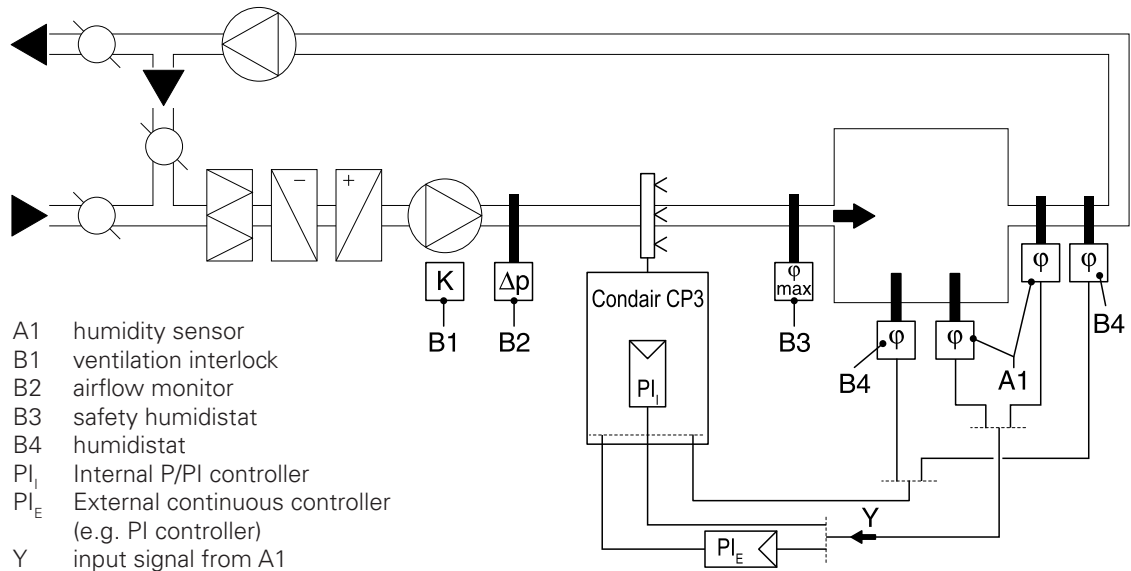

– System 2: Room humidity control with continuous limitation of the supply air humidity

System 2 is suited for air conditioning systems with a **large portion of supply air, low supply air temperature, post-humidification, or variable airflow volume**. If the supply air humidity exceeds the preset value, the continuous limitation is effected prior to the room humidity control. The humidity sensor (A1) is preferably located in the exhaust air duct or in the room itself. The humidity sensor (A2) for the limitation of the supply air humidity is located in the supply air duct after the steam distribution pipe. This control system requires a continuous controller with the option to connect a second humidity sensor.

Attention! The continuous limitation of the supply air humidity is no substitute for the safety humidistat.

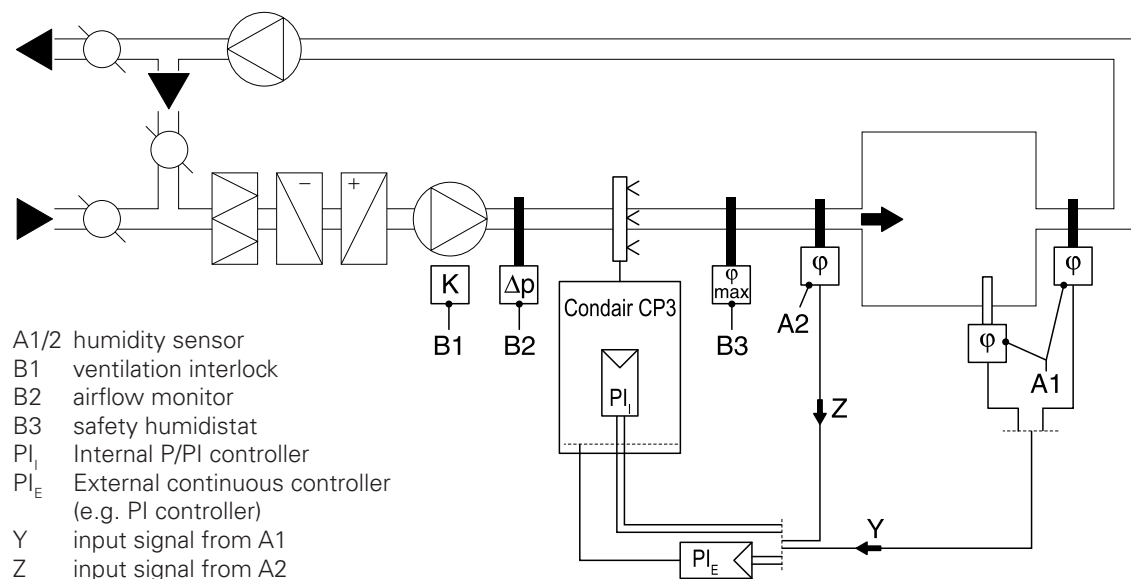

– **System 3: Supply air humidity control with continuous output limitation**

Supply air humidity control (humidity sensor installed in supply air duct) should be used only where room humidity control is impracticable for technical reasons. Such systems always require a PI-controller.

The humidity sensor (A1) is located in the supply air duct after the steam distribution pipe. The humidity sensor (A2) for the continuous output limitation is located in the supply air duct before the steam distribution pipe. Such a system requires a PI-controller with the option to connect a second humidity sensor.

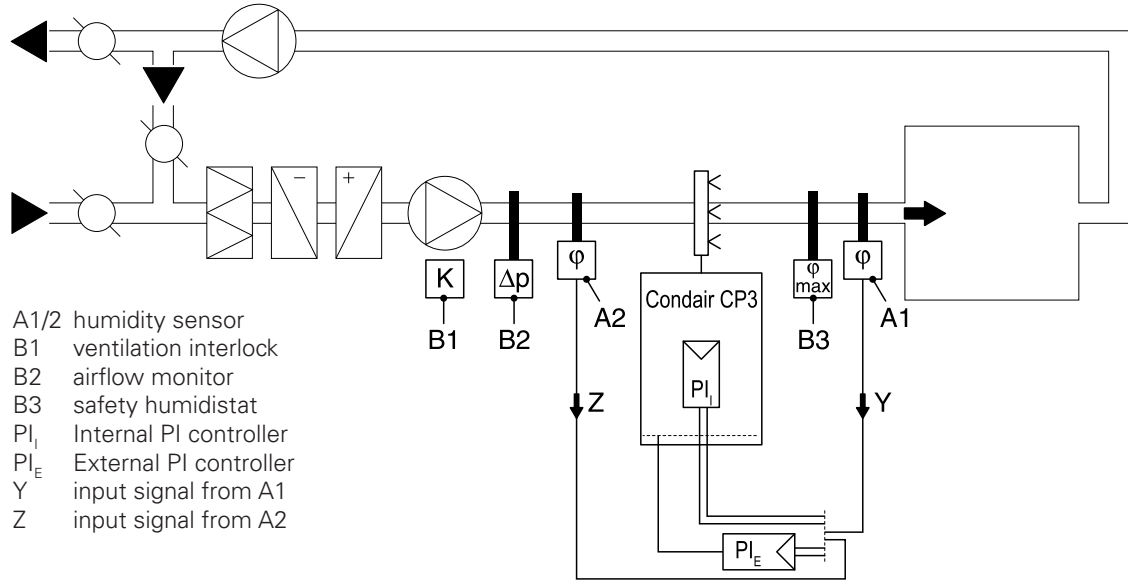

Which humidity control system for which application?

Application	Location of the humidity sensor	
	room or exhaust air duct	supply air duct
Air conditioning systems with:		
– supply air portion up to 33%	System 1	System 1
– supply air portion up to 66%	System 1 or 2	System 2 or 3
– supply air portion up to 100%	System 2	System 3
– supply air humidity control	—	System 3
Direct room humidification	System 1	—

Please contact your Condair supplier, if your application meets the following conditions:

- Humidification of small rooms up to 200 m³
- Air conditioning systems with a high number of air exchanges
- Systems with variable air volume flow
- Test facilities with extreme control accuracy requirements
- Rooms with a high variation in max. steam capacity
- Systems with temperature fluctuations
- Cold rooms and systems with dehumidification

Input signals

Control with external controller Control signals	Control with internal PI controller Humidity sensor signals
0...5 VDC (Potentiometer 135 Ω ... 10 k Ω)	0...5 VDC (Potentiometer 135 Ω ... 10 k Ω)
1...5 VDC	1...5 VDC
0...10 VDC	0...10 VDC
2...10 VDC	2...10 VDC
0...16 VDC	0...16 VDC
3.2...16 VDC	3.2...16 VDC
0 ... 20 mA	0 ... 20 mA
4 ... 20 mA	4 ... 20 mA
Humidistat (24 V On/Off)	

5 Mounting and installation work

5.1 Important notes for mounting and installation work

Qualification of personnel

All mounting and installation work must be carried out only by **well qualified personnel authorised by the owner**. It is the owner's responsibility to verify proper qualification of the personnel.

General note

Strictly observe and comply with all information given in the present Technical Documentation regarding the location of the unit and the installation of water, steam and electricity.

Observe and comply with all local regulations dealing with water, steam and electrical installations.

Safety

Some installation work requires removal of the unit cover. Please note the following:

 WARNING!	Danger of electrical shock! You may get in touch with live parts when the unit is open. The steam humidifier must be connected to the mains only after all mounting and installation work has been completed and the cover has been relocated properly.
CAUTION!	The electronic components inside the humidifier are very sensitive to electrostatic discharge . When the unit is open for installation work, appropriate measures must be taken to protect these components against damage caused by electrostatic discharge (ESD protection).

5.2 Installation overview

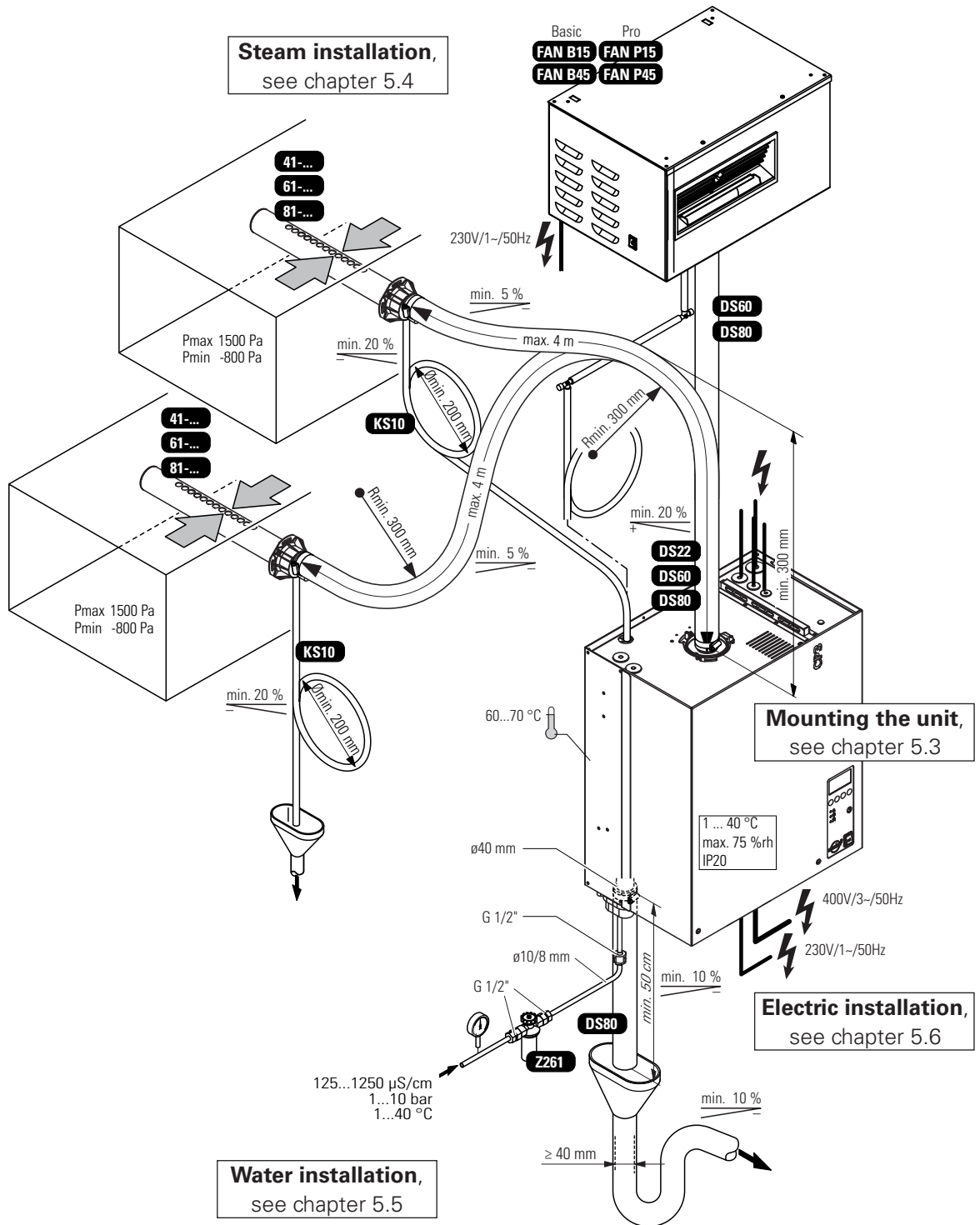

5.3 Mounting the unit

5.3.1 Notes on locating the unit

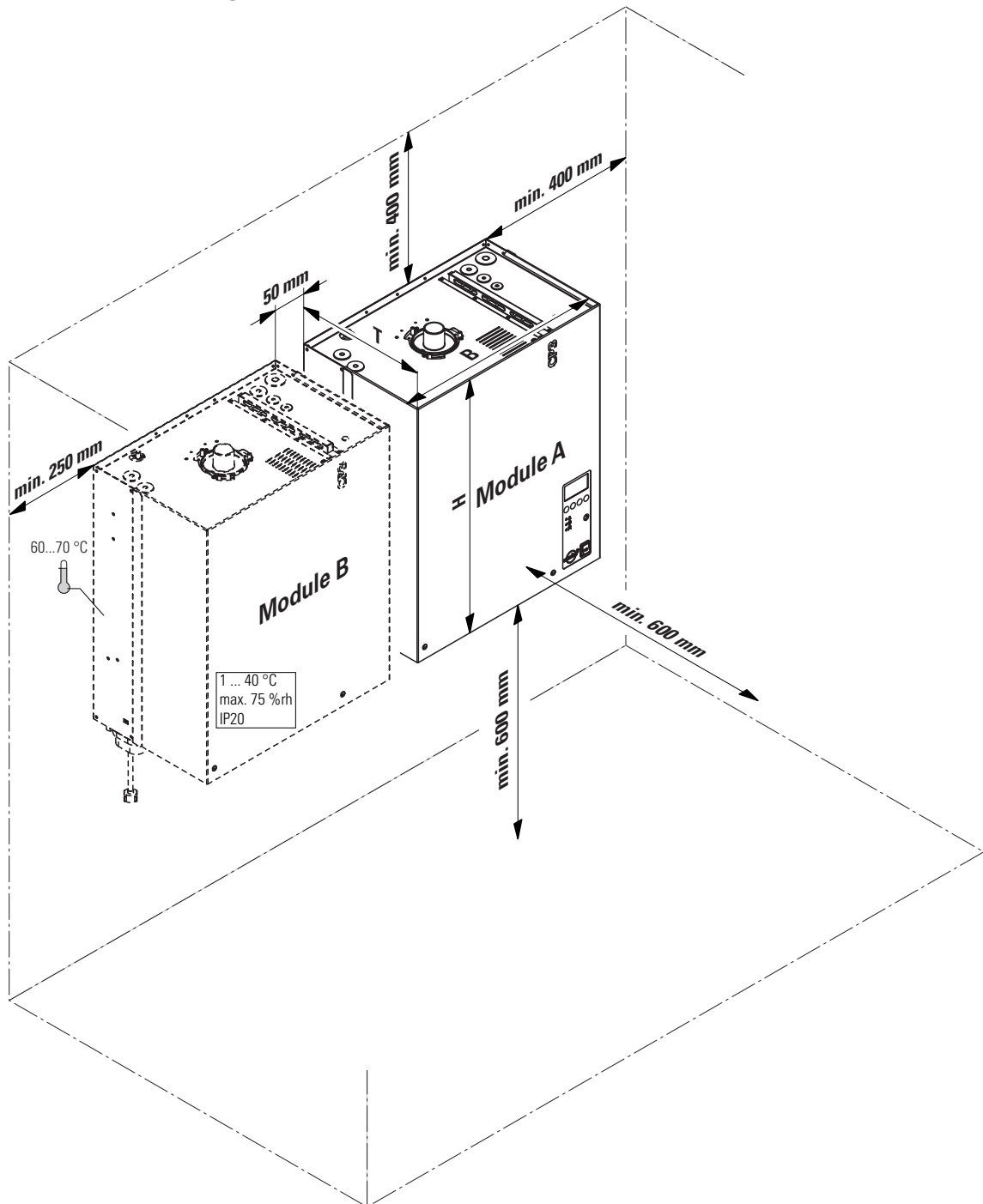

Condair CP3 ... 230V1	Basic	Pro										
		5..8										
Condair CP3 ... 230V3	Basic	Pro	Basic	Pro	Basic	Pro	Basic	Pro	Basic	Pro	Pro	Pro
	5..8		9..15		16..21		22..30		44/50		75/90	
Condair CP3 ... 400V3	Basic	Pro	Basic	Pro	Basic	Pro	Basic	Pro	Basic	Pro	Pro	Pro
	5..8		9..15		16..25		26..45		52/60/70/80/90		105/120/135	

Dimensions												
Housing (BxHxT) in mm	456x620x280	1	1									
	559x667x350			1	1	2	3	4				
Weights												
Net weight in kg		21	21	21	28	2x 28	3x 28	4x 28				
Operating weight in kg		26	32	32	65	2x 65	3x 65	4x 65				

The installation site of the steam humidifier depends largely on the location of the steam distributor (see chapter 5.4). To **ensure proper functioning** of the steam humidifier and to **obtain an optimal efficiency**, the following points must be considered and observed when choosing the location for the steam humidifier:

- Install the steam humidifier so that the **length of the steam** hose is kept as short as possible (**max. 4 m**) and that the **minimum bend radius (R= 300 mm)** and **up-slope (20 %)** or **down-slope (5 %)** of the steam hose is observed (see chapter 5.4.5).
- The steam humidifiers Condair CP3 are designed for wall-mounting. Make sure that the construction (wall, pillar, floor-mounted console, etc.) to which the humidifiers are to be mounted, offers a **sufficiently high load-bearing capacity** (take notice of the weight information found in the dimension and weights table above), and is suitable for the installation.

CAUTION!

Do **not** mount the steam humidifier directly to the ventilation duct (insufficient stability).

- The back panel of the Condair CP3 is retaining heat during operation (max. surface temperature of the metal housing approx. 60 - 70 °C). Make sure, therefore, that the construction (wall, pillar, etc.) to which the units are to be mounted, does not consist of heat-sensitive material.
- Install the steam humidifier in such a manner that it is **freely accessible** with sufficient space available for maintenance purposes (refer to the above illustration for minimum distances).
- The Condair CP3 is protected according to **IP20**. Make sure the units are installed in a drip-proof location and the admissible ambient conditions are complied with.
- The steam humidifier Condair CP3 may only be installed in rooms with a floor drain.

CAUTION!

If for some reason the Condair CP3 must be installed in a location without floor drain, it is mandatory to provide a leakage monitoring device to safely interrupt the water supply in case of leakage.

- When fixing the Condair CP3 use **only the fixing materials supplied with the unit**. If fixing with the materials supplied is not possible in your particular case, select a method of fixing that is of similar stability.

5.3.2 Mounting the humidifier

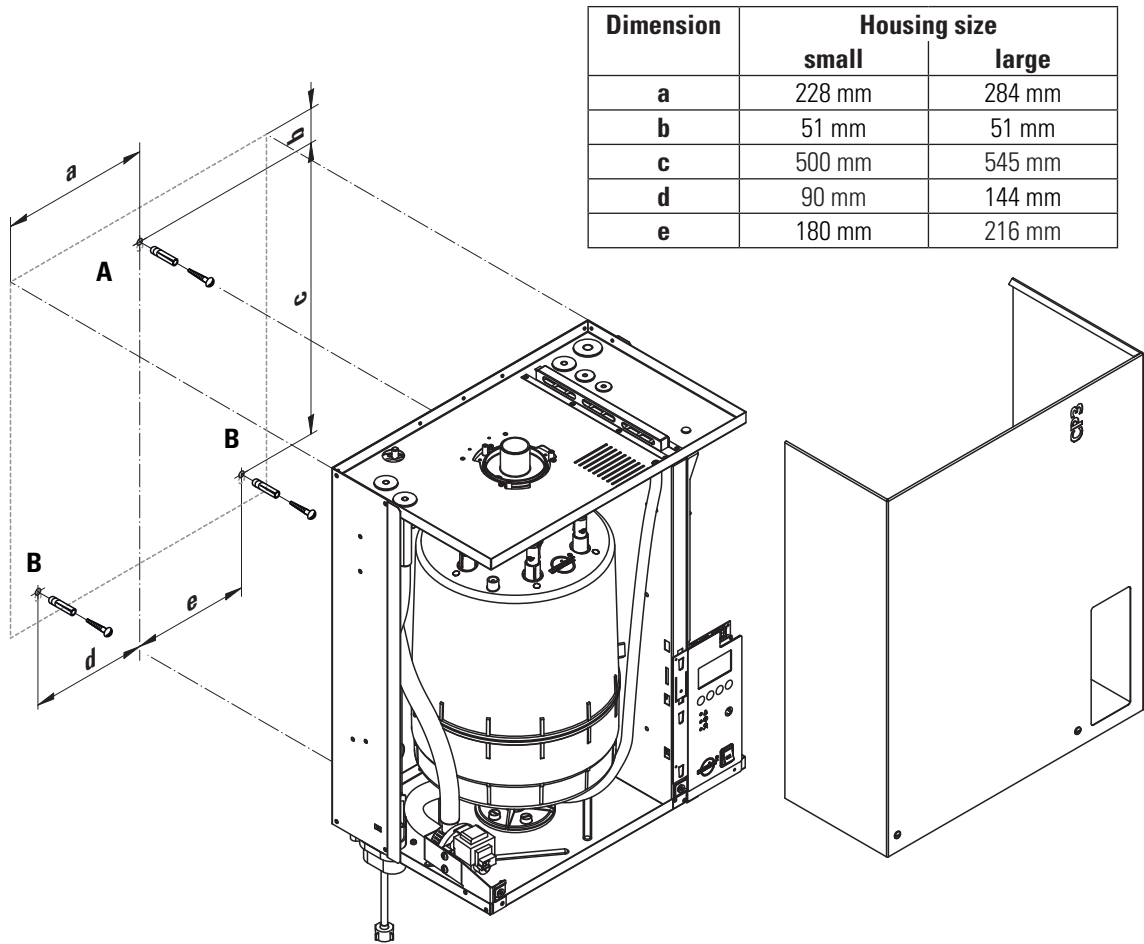

Procedure

1. Mark the attachment point "A" on the wall.
2. Drill hole for attachment point "A" (diameter: 8 mm, depth: 40 mm).
3. Insert the supplied plastic plug, and tighten the screw until the distance between the wall and the screw head is 4 mm.
4. Unlock the two screws fixing the front panel to the unit, then remove the front panel.
5. Hang up the unit onto the screw and adjust it horizontally and vertically using a spirit level. Then, mark the fixing points "B".
6. Drill the holes for the fixing points "B" (diameter: 8 mm, depth: 40 mm).
7. Insert the supplied plastic plugs, and tighten the screws until the distance between the wall and the screw head is 4 mm.
8. Hang the unit up onto the screws. Before tightening the screws, readjust the unit with the spirit level.
9. Reattach the front panel and secure it with the two screws.

5.3.3 Inspecting the installed unit

Check the following points:

- Is the unit installed in the correct place (see chapter 5.3.1)?
- Is the supporting surface stable enough?
- Is the unit correctly aligned, vertically and horizontally?
- Is the unit properly secured (see chapter 5.3.2)?
- Has the front panel of the unit been relocated and correctly fixed with the two screws?

5.4 Steam installation

5.4.1 Overview steam installation

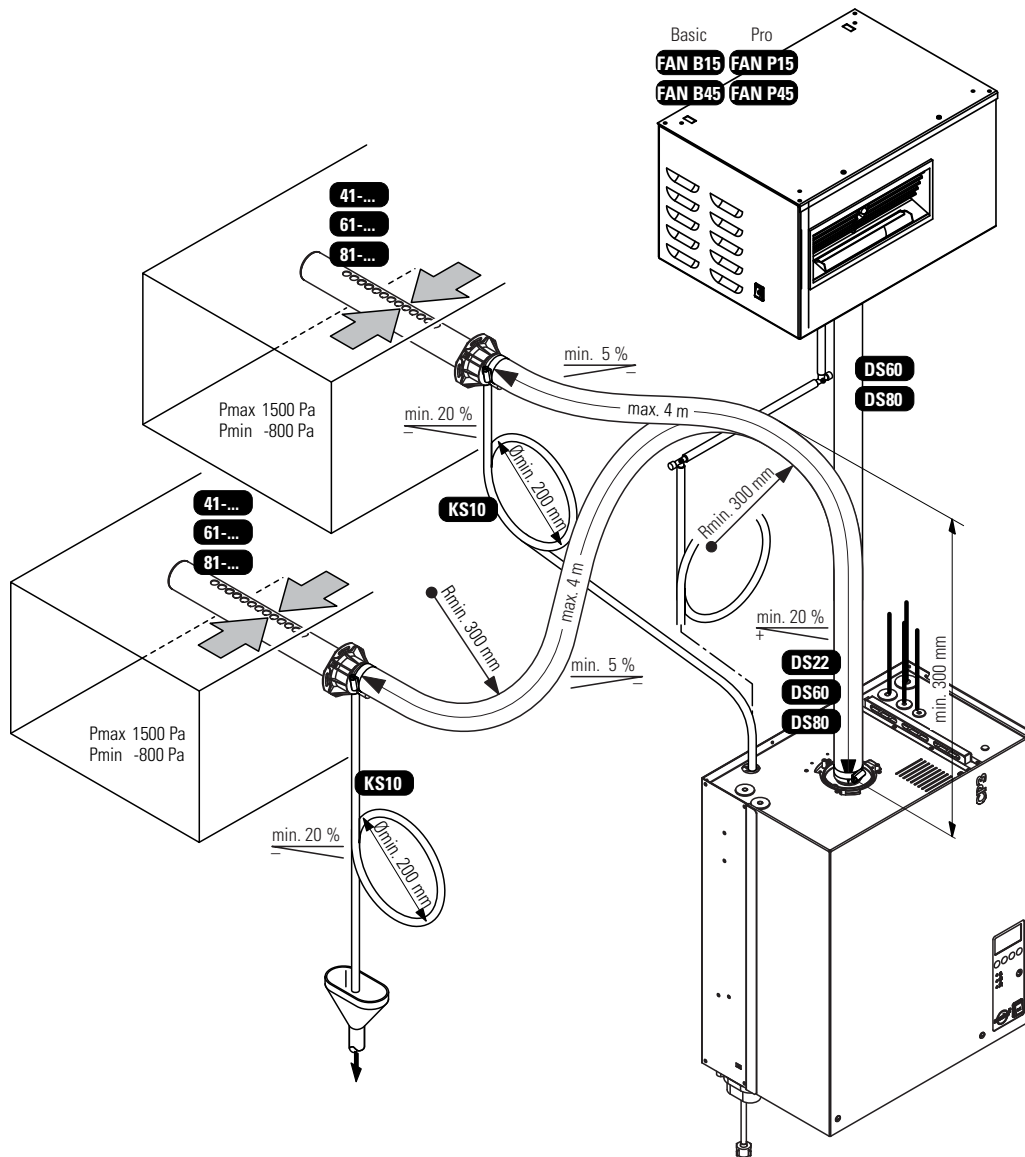

5.4.2 Positioning and mounting of the steam distribution pipes

The location for the steam distribution pipes should be determined at the time of dimensioning the air conditioning system. Please note the following instructions to ensure proper humidification of the duct air.

Calculating the humidification distance

The water vapour, emitting from the steam distribution pipes, requires a certain distance to be absorbed by the ambient air so that it is no longer visible as steam. This distance is referred to as **humidification distance "B_N"** and serves as a basis for the determination of the minimum distances from the upstream components in the system.

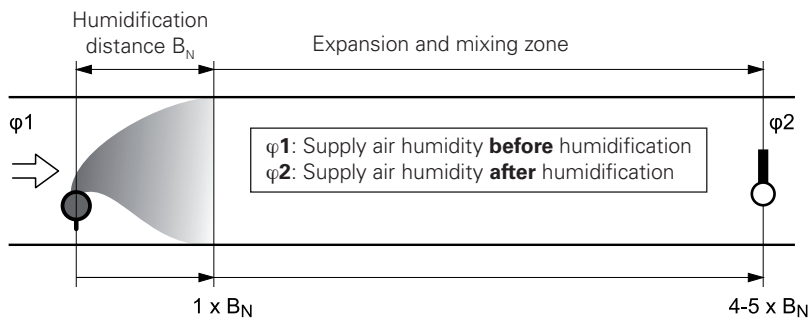

The calculation of the humidification distance "B_N" is dependent on several factors. For a rough estimation of the humidification distance "B_N", the following table is useful. Recommended standard values listed in this table are based on a supply-air temperature range of 15 °C to 30 °C. The values given in bold type **only apply to steam distribution pipes 41-..., 61-... and 81-...**, the values in brackets apply to the OptiSorp steam distribution system.

Humidity at inlet φ1 in %rh	Length of humidification distance B _N in m					
	Humidity at outlet φ2 in %rh					
	40	50	60	70	80	90
5	0,9 (0,22)	1,1 (0,28)	1,4 (0,36)	1,8 (0,48)	2,3 (0,66)	3,5 (1,08)
10	0,8 (0,20)	1,0 (0,26)	1,3 (0,34)	1,7 (0,45)	2,2 (0,64)	3,4 (1,04)
20	0,7 (0,16)	0,9 (0,22)	1,2 (0,30)	1,5 (0,41)	2,1 (0,58)	3,2 (0,96)
30	0,5 (0,10)	0,8 (0,17)	1,0 (0,25)	1,4 (0,36)	1,9 (0,52)	2,9 (0,88)
40	–	0,5 (0,11)	0,8 (0,20)	1,2 (0,30)	1,7 (0,45)	2,7 (0,79)
50	–	–	0,5 (0,13)	1,0 (0,24)	1,5 (0,38)	2,4 (0,69)
60	–	–	–	0,7 (0,16)	1,2 (0,30)	2,1 (0,58)
70	–	–	–	–	0,8 (0,20)	1,7 (0,45)

For duct widths <600 mm the humidification distance for the OptiSorp system increases by approx. 50%

φ1 in %rh: Relative supply air humidity prior to humidification at the lowest supply air temperature

φ2 in %rh: Relative supply air humidity after the steam distribution pipe at maximum capacity

Example	
given:	φ1= 30 %rh, φ2= 70 %rh
humidification distance B _N :	1,4 m (0,36 m for steam distribution system OptiSorp)

Note: If the humidification distance has to be reduced for technical reasons, the amount of steam per basic unit must be divided between **two steam distribution pipes** or the **steam distribution system OptiSorp** must be used. If this is the case, contact your Condaair supplier.

Minimum distances to be observed

To prevent the water vapour, that is emitting from the steam distribution pipe, from condensing on downstream system components, a minimum distance to the steam distribution pipe must be observed (depends on the humidification distance " B_N ").

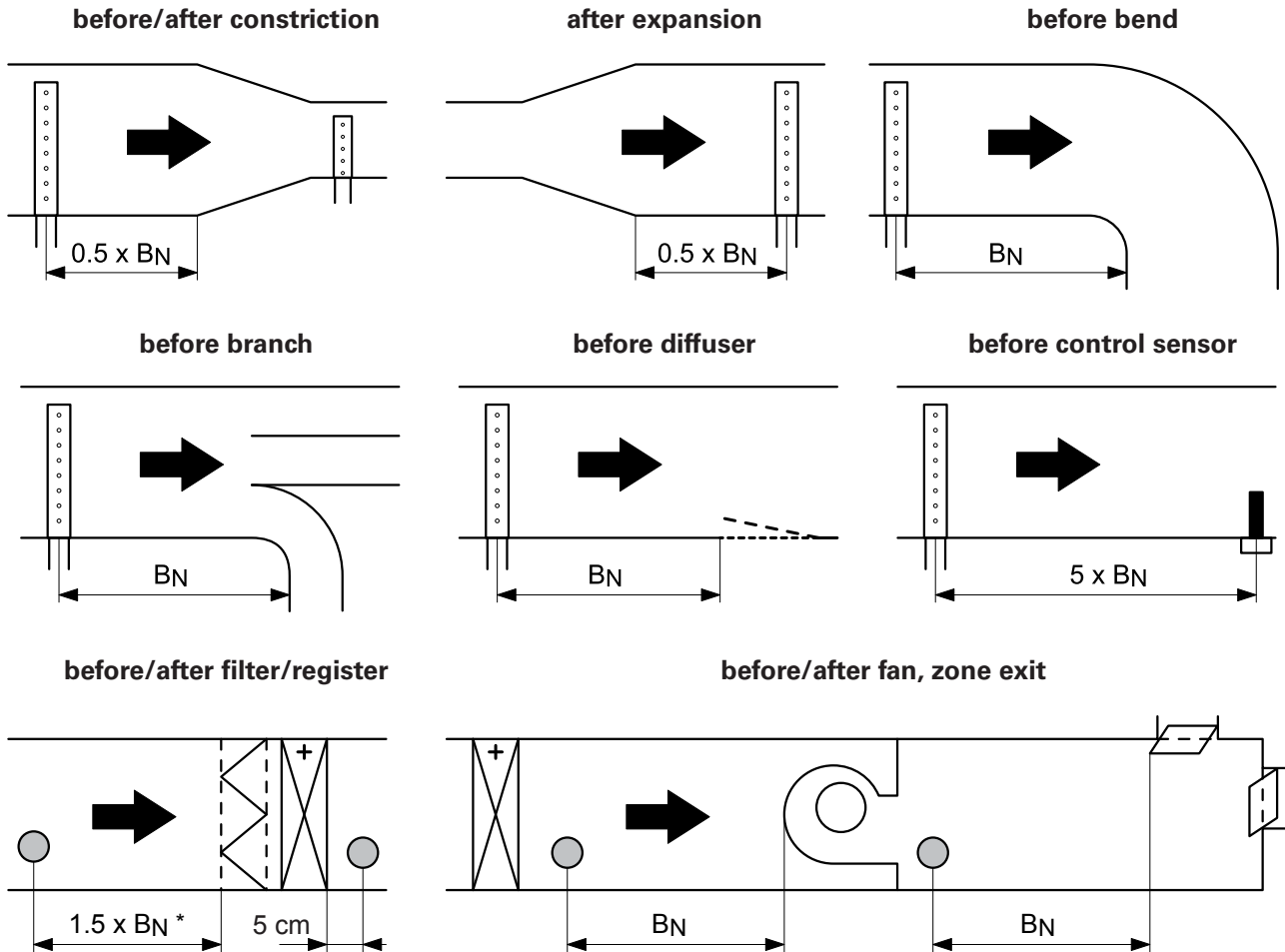

$2,5 \times B_N$ before aerosol filter

Installation notes and dimensions

The steam distribution pipes are designed for either **horizontal** installation (on the duct wall) or, with accessories, for **vertical** installation (in the duct floor). The **outlet orifices should always point upwards and at right angles to the airflow**.

If possible, the steam distribution pipes should be installed on the **pressure side** of the duct (**max. duct pressure 1500 Pa**). If the steam distribution pipes are installed on the suction side of the duct, the **maximum vacuum must not exceed 800 Pa**.

Select a location for the installation, tailored to suit your duct (see the following illustrations) and position the steam distribution pipes in the duct so that a uniform distribution of steam is achieved.

In positioning the steam distribution pipes, the following dimensions should be observed:

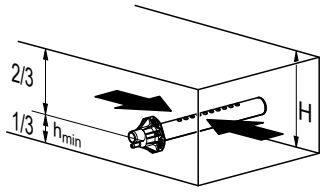

H min.= 250 mm

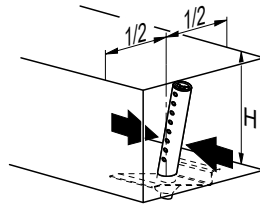

H ≥ 400 mm

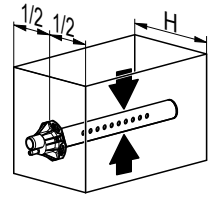

H min.= 200 mm

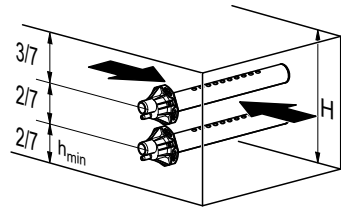

H min.= 400 mm

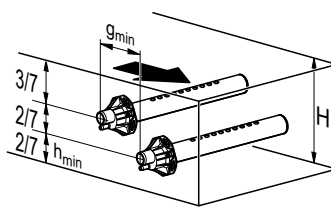

H min.= 350 mm

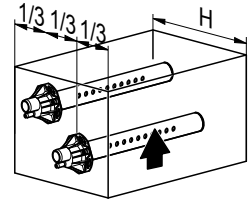

H min.= 300 mm

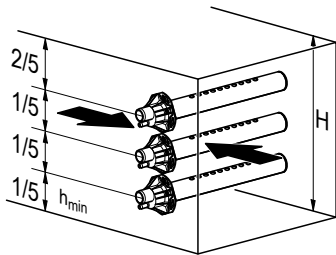

H min.= 600 mm

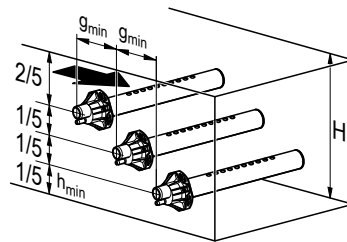

H min.= 500 mm

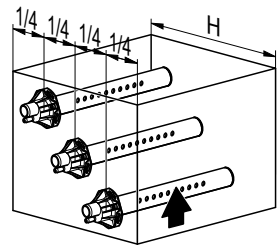

H min.= 400 mm

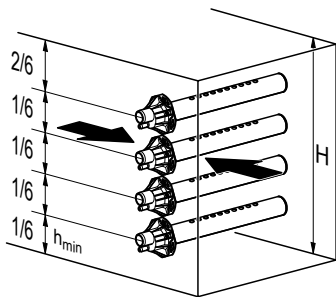

H min.= 720 mm

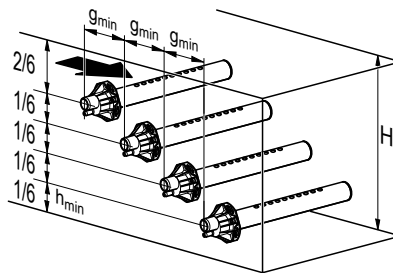

H min.= 600 mm

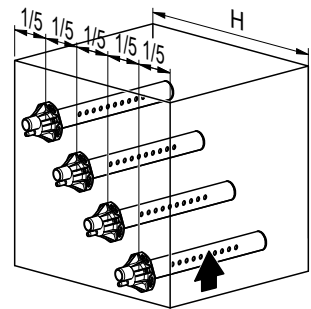

H min.= 500 mm

g min.= 100 mm
h min.= 85 mm

Note: When locating the OptiSorp steam distribution system please note the instructions in the separate documentation for this product.

Guidelines for dimensioning the ventilation ducts

- To facilitate the installation of the steam distribution pipes and for control purposes, a sufficiently sized control opening should be planned.
- Within the range of the humidification distance, the ventilation duct should be waterproofed.
- Air ducts passing through cold rooms should be insulated to prevent the humidified air from condensing along the duct wall.
- Poor airflow conditions within the air duct (e.g. caused by obstacles, tight bends, etc.) can lead to condensation of the humidified air.
- Steam distribution pipes must not be mounted to round ducts.

If you have questions relating to the dimensioning of ventilation ducts in combination with steam humidifiers Condair CP3, contact your Condair supplier.

5.4.3 Installing the steam distributors

Detailed information on the installation of steam distribution pipes 41-., 61-../81-... and OptiSorp steam distribution system can be found in the separate "Mounting Instructions" for this products.

5.4.4 Positioning and mounting of the fan unit

The fan unit is mounted on the wall **separately above the unit**. To allow the steam coming from the fan unit to spread out evenly, without condensing on obstacles (ceilings, joists, pillars, etc.), the following minimum dimensions must be observed when selecting the location for the fan unit.

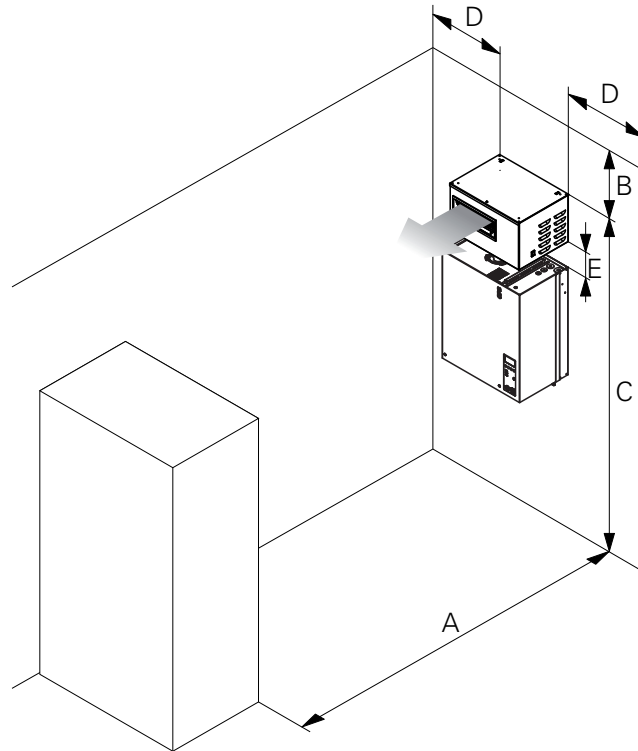

	FAN B15/FAN P15		FAN B45/FAN P45	
m_d max.	8 kg/h	15 kg/h	30 kg/h	45 kg/h
A min.	3.0 m	6.0 m	8.0 m	10.0 m
B min.	0.5 m	0.7 m	1.0 m	1.5 m
C approx.	2.2 m	2.2 m	2.2 m	2.2 m
D approx.	0.5 m	0.7 m	1.0 m	1.5 m
E	0.15...2.0 m	0.2...2.0 m	0.3...2.0 m	0.5...2.0 m

Note: The minimum spaces in the table apply for a room atmosphere of 15 °C and max. 60 %rh. For lower temperatures and/or higher humidity the values should be adjusted accordingly

Note: In order to achieve a uniform distribution of the humidity within the room, additional factors such as the room size, the room height, etc., must be taken into consideration besides observing the minimum distances. If you have questions concerning the direct room humidification, please contact your Condair supplier.

Further information is provided in the separate "Technical documentation for the fan unit"

5.4.5 Installing the steam hose

Important! Use original Condaire steam hose exclusively. Other types of steam hoses can cause undesired operational malfunctions.

Instructions for the hose layout

The hose layout depends on the position of the steam distribution pipe:

- Steam distribution pipe is mounted **more than 300 mm above the top edge of the humidifier:**

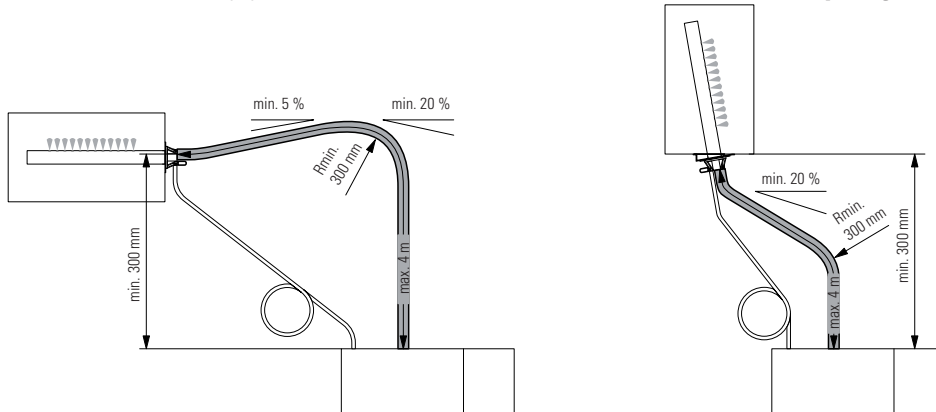

Initially, lead the steam hose with an **upslope of at least 20% over a minimum height of 300 mm**, then lead the hose with a **minimum upslope of 20%** and/or a **minimum downslope of 5%** to the steam distribution pipe.

- Steam distribution pipe is mounted **less than 300 mm above the top edge of the humidifier:**

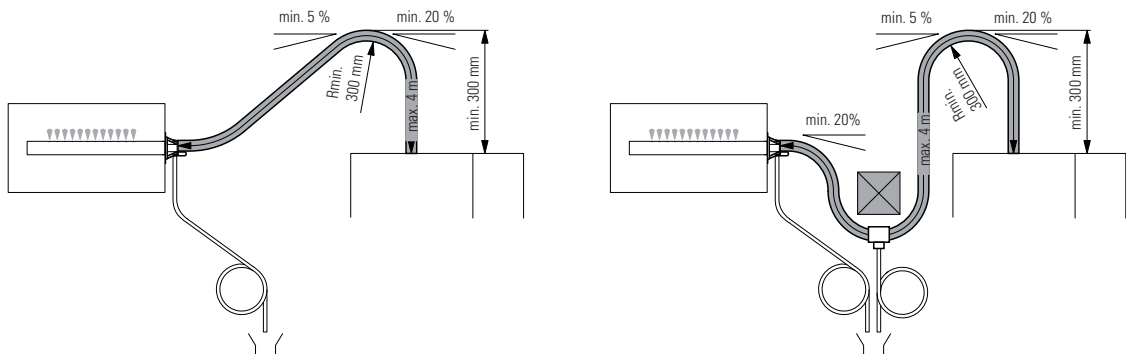

Initially, the steam hose is led with an **upslope of at least 20% over a minimum height of 300 mm** above the top edge of the humidifier and then down to the steam distribution pipe with a **minimum slope of 5%**.

- The steam hose should be kept as short as possible (**max. 4 m**) while observing the **minimum bend radius of 300 mm**. **Important!** Allowance must be made for a **pressure loss of 10 mm water column (approx. 100 Pa)** per meter steam hose.
Note: If your particular installation exceeds the maximum steam hose length of 4 m contact your Condaire representative. In any case, steam hoses longer than 4 m must be insulated in their entire length.
- Reductions in the cross section such as kinks should be avoided throughout the entire length of the hose. The installation of a stop cock in the steam hose is not permissible.

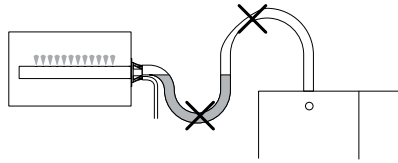

- Steam hoses must be prevented from sagging (condensate pockets); if necessary, support with pipe clamps, trough, or wall brackets, or install a condensate drain in the steam hose.
- **Important!** When deciding on the length and layout of the hose, it should be noted that the steam hose may become somewhat shorter with progressive ageing.

Securing the hose

The steam hose must be secured to the steam distribution pipe and humidifier steam outlet by means of **hose clamps**.

Caution! Do not overtighten the hose clamp on the steam connector of the steam humidifier.

Steam line with fixed piping

For steam lines with fixed piping, the same instructions apply to the laying of the piping as already described. The following additional notes should be observed:

- The **minimum internal diameter of 22 mm, 30 mm or 45 mm** respectively should be applied over the whole length of the piping.
- Use exclusively Cu pipe or stainless steel (min. DIN 1.4301).
- To minimize the condensate formation (=loss), the steam pipes must be insulated.
- The **minimum bend radius** for solid pipes is **4-5 x internal diameter**.
- Connection of the steam pipes to the steam distribution pipe and steam humidifier is effected by means of short lengths of steam hose secured with hose clamps. Connection to the steam humidifier is secured via a G 2" coupling.
- **Important!** Allowance must be made for a **pressure loss of 10 mm water column (approx. 100 Pa)** per meter length or per 90° bend.

5.4.6 Installing the condensate hose

Important! Use original Condair condensate hose exclusively. Other types of hoses can cause operational malfunctions.

The hose layout depends on the position of the steam distribution pipe:

- Steam distribution pipe is mounted **more than 300 mm above the top edge of the humidifier**:
Condensate hose is led down to the humidifier with a **minimum slope of 20 %**, in the form of a **siphon (min. hose bend diameter Ø200 mm)**, and inserted about 2 cm into the specified opening.

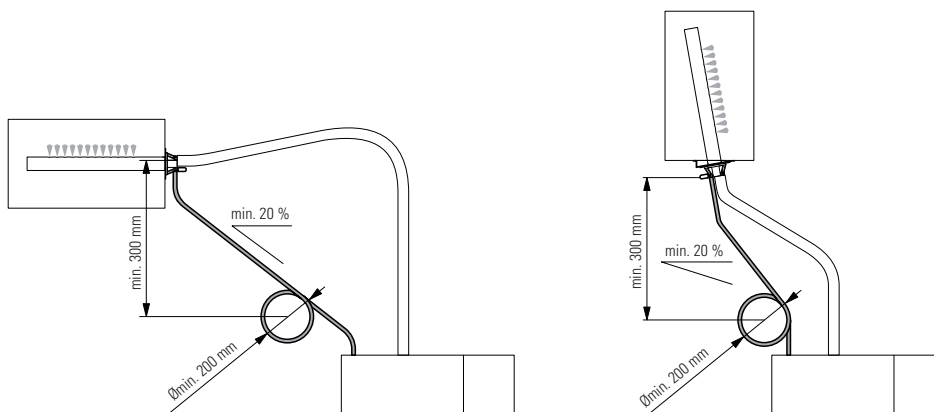

- Steam distribution pipe is mounted **less than 300 mm above the top edge of the humidifier**:
Condensate hose is led down with a **minimum slope of 20 %**, in the form of a **siphon (min. hose bend diameter Ø200 mm)**, directly into a discharge funnel.

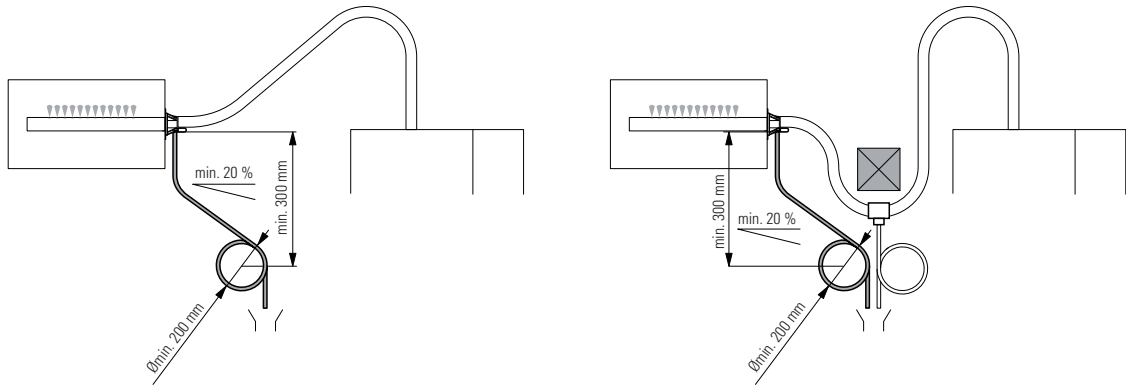

Note: If your unit feeds a number of steam distribution pipes, the individual condensate hoses are to be led into the discharge funnel.

Important! Before putting the unit into operation, the siphon of the condensate hose must be filled with water.

5.4.7 Inspecting the steam installation

Use the following check list to ascertain that the steam installation was performed correctly:

- Steam distribution pipe
 - Steam distributors (steam distribution pipe or OptiSorp steam distribution system) correctly positioned and secured (screws tightened)?
 - Are the outlet orifices at right angles to the air flow direction?
- Steam hose
 - Maximum length of 4 m?
 - Minimum bend radius of 300 mm (4-5 x internal diameter with fixed piping)?
 - Have the instructions for hose positioning been followed?
 - Steam hose: no sagging (condensate pocket) or condensate drain with siphon (hose bend with a minimum diameter of 200 mm) installed at the lowest point?
 - Rigid steam lines: properly insulated? Correct installation material used? Minimum internal diameter maintained?
 - Steam hose(s) securely attached with clamps?
 - Heat expansion during operation and shortening of the hose with ageing taken into consideration?
- Condensate hose
 - Downslope of at least 20 %?
 - Siphon (min. \varnothing 200 mm) existing and filled with water?
 - Condensate hose correctly fixed and not kinked?

5.5 Water installation

5.5.1 Overview water installation

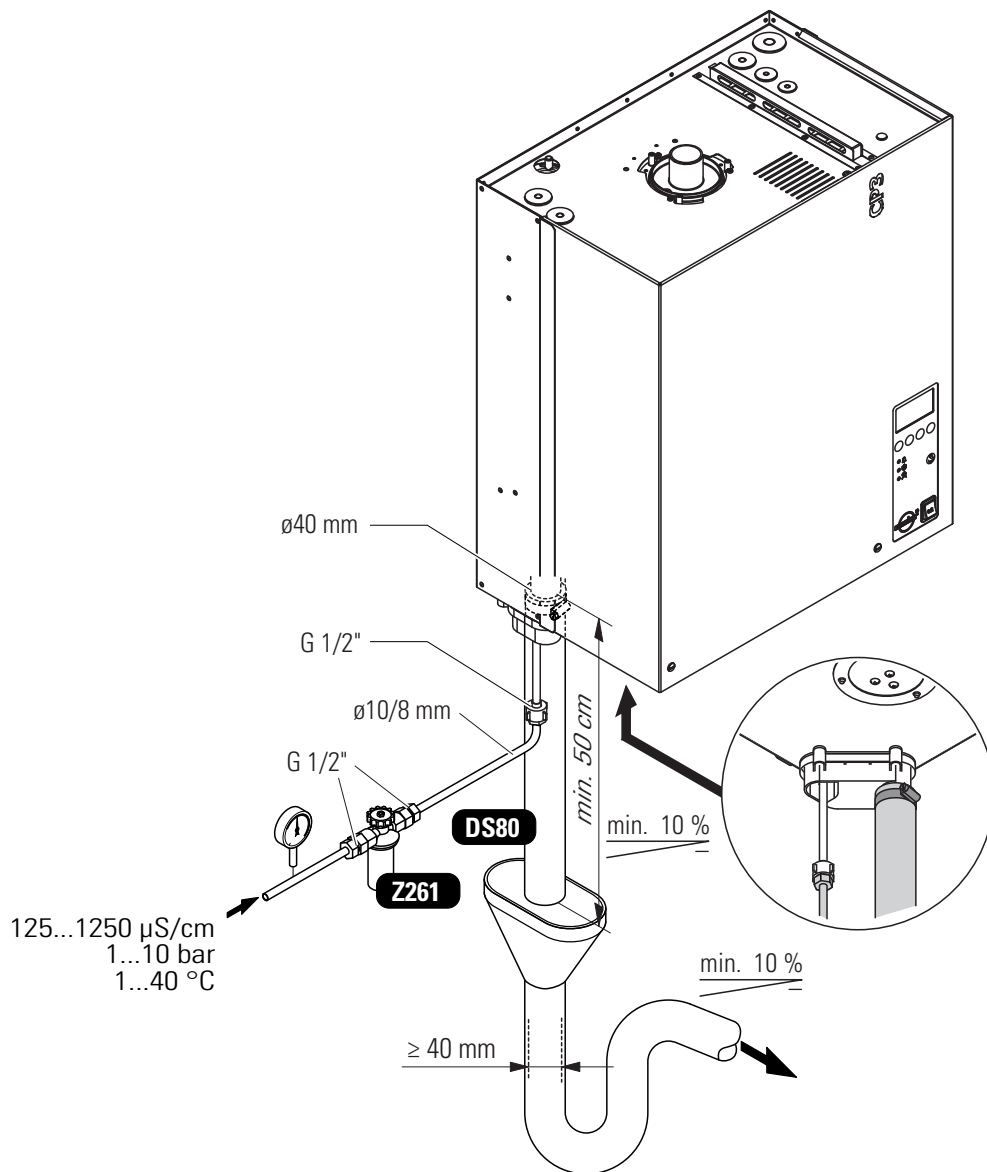

5.5.2 Notes on water installation

Water supply

The water supply is to be carried out according to the figure found in chapter 5.5.1 and the applicable local regulations for water installations. The indicated connection specifications must be observed.

- The installation of the **filter valve** (accessory “Z261”, alternatively a shut-off valve and a 5 µm water filter can be used) should be made as close as possible to the steam humidifier.
- Admissible mains pressure **1.0 to 10.0 bar (hammer-free system)**
For mains pressures >10 bar, the connection must be made via a pressure reducing valve (adjusted to 1.0 bar). For mains pressures <1.0 bar please contact your Condair supplier.
- **Notes on water quality:**
 - For the water supply of the Condair CP3, use exclusively **untreated drinking water**.
 - The use of **additives** such as corrosion inhibitors, disinfectants, etc. is **not allowed**, since these additives may endanger health and affect proper operation.
 - If the Condair CP3 shall be operated with softened or partly softened water, please contact your Condair supplier.
- The connection material must be **pressure-proof** and **certified for use in drinking water systems**.
- **Important!** Before connecting the water line, **the line should be well flushed out**.

CAUTION!	The thread at the humidifier connection is made of plastic. To avoid overtightening, the union nut of the water pipe must be tightened by hand only.
-----------------	---

Water drain

The water drain is to be carried out according to the figure found in chapter 5.5.1 and the applicable local regulations for water installations. The indicated connection specifications must be observed.

- Make sure that the drain pipe is correctly fixed and easily accessible for inspections and cleaning purposes.
- The draining temperature is: **80...90 °C** (approx. 70...80 °C with activated drain water cooling). Use temperature-resistant installation materials only!

5.5.3 Inspecting the water installation

Check the following topics:

- Water supply
 - Has filter valve (accessory "Z261") or shut-off valve and 5 µm water filter respectively been installed in supply line?
 - Have admissible water pressure (1 – 10 bar) and admissible temperature (1 – 40 °C) been observed?
 - Does the supply capacity match the humidifier and is the minimum inside diameter of the supply pipe maintained throughout the entire length?
 - Are all components and pipes properly secured and are all threaded connections securely tightened?
 - Is the water system properly sealed?
 - Does the water supply installation meet the requirements of the local regulations for water installations?
- Water drain
 - Is the minimum inside diameter of the drain pipe of 40 mm maintained throughout the entire length?
 - Has drain pipe been installed with a downslope of at least 10 %?
 - Has the heat resistance of the material used been verified to be at least 100 °C?
 - Is the drain hose properly secured (hose clamps at unit connection tightened)?
 - Does the water drain installation meet the requirements of the local regulations for water installations?

5.6 Electric installation

5.6.1 Wiring diagram Condair CP3 Basic/Pro

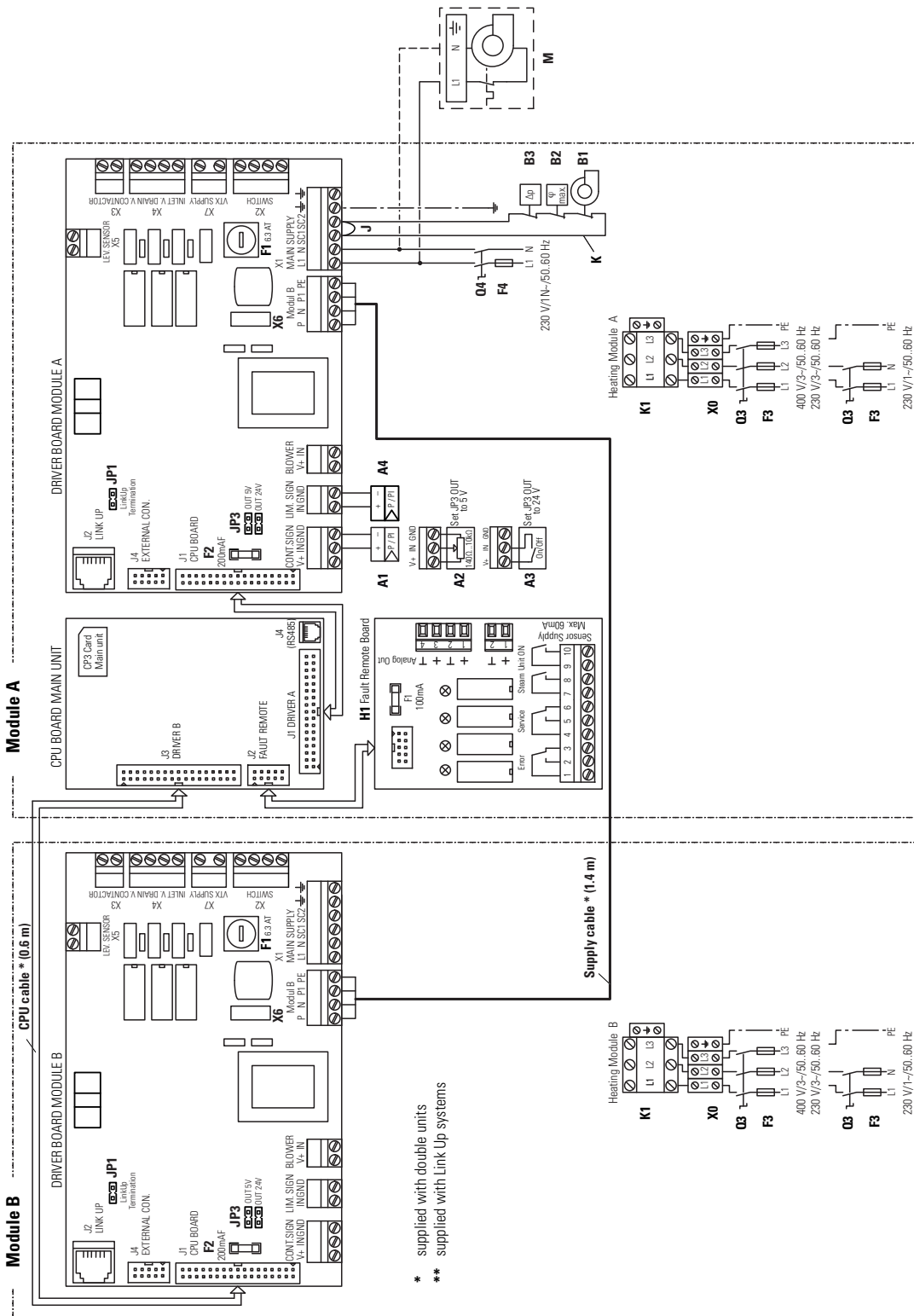

* supplied with double units
 ** supplied with Link Up systems

- A1 Controller (active) or humidity sensor
- A2 Controller (passive), set JP3 to position 5V
- A3 On/Off controller, set JP3 to position 24V
- A4 Limitation signal
- B1 Ventilation interlock
- B2 Safety humidistat
- B3 Airflow monitor
- F1 Internal fuse "Driver board" (6.3 A, slow acting)
- F2 Internal fuse "Driver board" control signal (200 mA, fast acting)
- F3 External fuse heating voltage supply
- F4 External fuse control voltage supply
- H1 Remote operating and fault indication
- J Short circuited, if no external monitoring devices are connected
- J2 Link Up system "Driver board"
- JP1 Termination Link Up system
- JP3 Jumper control signal
- K External safety chain (230V/5A)
- K1 Main contactor (for connecting the heating voltage supply to the unit)
- M Ventilation unit
- Q3 External service switch heating voltage supply
- Q4 External service switch control voltage supply
- X0 Connection terminal heating voltage (unit version Pro)
- X1 Connection terminal control voltage
- X6 Connection to module B

5.6.2 Wiring diagram Link Up systems

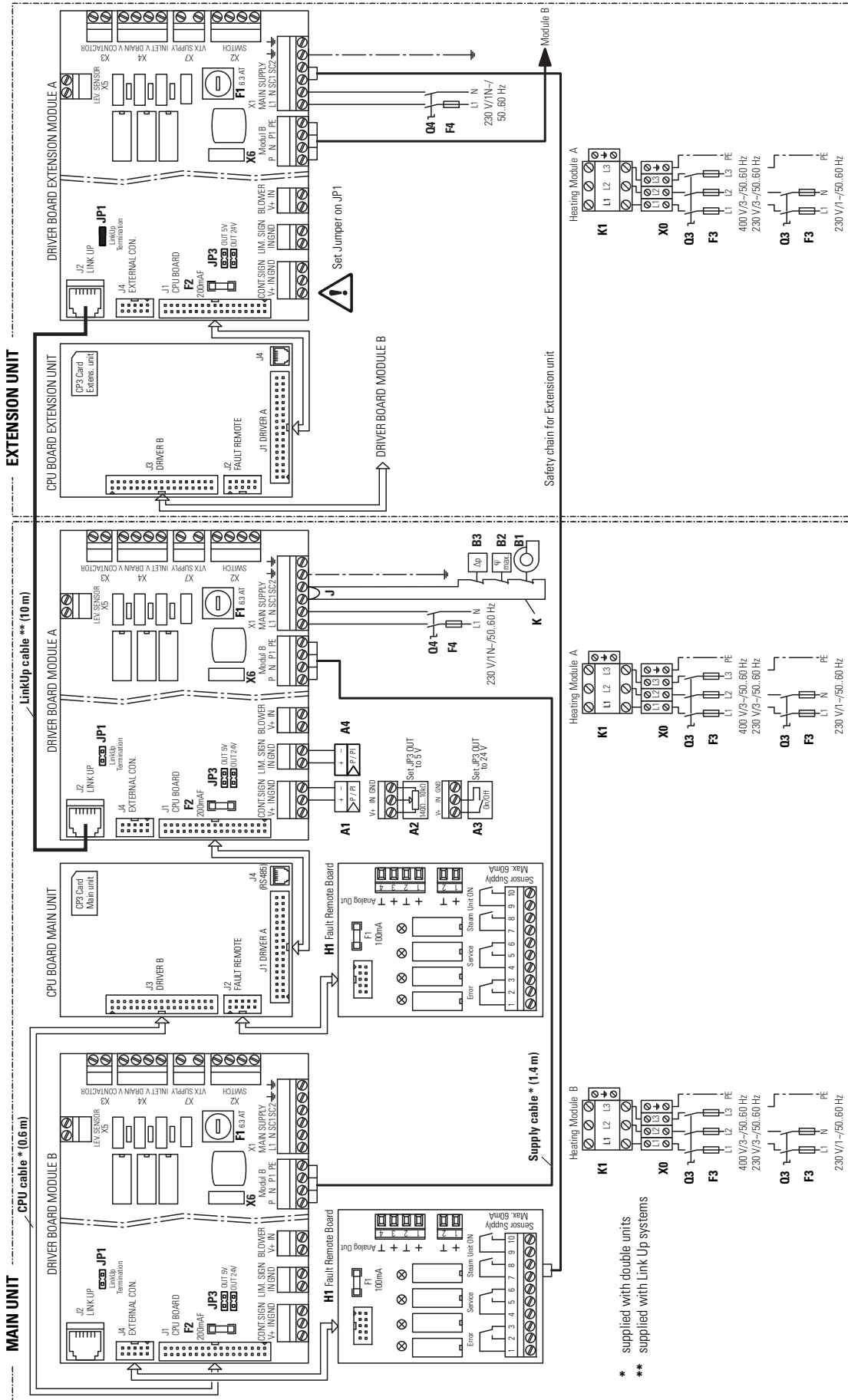

- A1 Controller (active) or humidity sensor
- A2 Controller (passive), set JP3 to position 5V
- A3 On/Off controller, set JP3 to position 24V
- A4 Limitation signal
- B1 Ventilation interlock
- B2 Safety humidistat
- B3 Airflow monitor
- F1 Internal fuse "Driver board" (6.3 A, slow acting)
- F2 Internal fuse "Driver board" control signal (200 mA, fast acting)
- F3 External fuse heating voltage supply
- F4 External fuse control voltage supply
- H1 Remote operating and fault indication
- J Jumper, if no external monitoring devices are connected
- J2 Link Up system "Driver board"
- JP1 Termination Link Up system
- JP3 Jumper control signal
- K External safety chain (230V/5A)
- M Main contactor (for connecting the heating voltage supply to the unit)
- O3 External service switch heating voltage supply
- O4 External service switch control voltage supply
- X0 Connection terminal heating voltage (unit version Pro)
- X1 Connection terminal control voltage
- X6 Connection to module B

5.6.3 Fuses F3 for heating voltage supply

Heating voltage	Max. steam capacity [kg/h]	Model Condaair CP3		Unit design **	Nominal power [kW]	Nominal current [A]	Main fuses F3 [A]
		Basic...	Pro...				
400V3 (400V/3~/50...60Hz)	5...8	5...8	5...8	EK	6.0	8.7	3x 10
	9...12	9...12	9...12	EK	9.0	13.0	3x 16
	13...15	13...15	13...15	EK	11.3	16.3	3x 20
	16...20	16...20	16...20	EG	15.0	21.7	3x 25
	21...25	21...25	21...25	EG	18.8	27.1	3x 35
	26...30	26...30	26...30	EG	22.5	32.5	3x 40
	31...42	31...42	31...42	EG	31.5	45.5	3x 50
	43...45	43...45	43...45	EG	33.8	48.8	3x 63
	52	52	52	DG	2x 19.5	2x 28.1	2x (3x 40)
	60	60	60	DG	2x 22.5	2x 32.5	2x (3x 40)
	70	70	70	DG	2x 26.3	2x 37.9	2x (3x 63)
	80	80	80	DG	2x 30.0	2x 43.3	2x (3x 63)
	90	90	90	DG	2x 33.8	2x 48.8	2x (3x 63)
	105	--	105	DG + EG	3x 26.3	3x 37.9	3x (3x 63)
	120	--	120	DG + EG	3x 30.0	3x 43.3	3x (3x 63)
	135	--	135	DG + EG	3x 33.8	3x 48.8	3x (3x 63)
	152	--	152	2x DG	4x 28.5	4x 41.1	4x (3x 63)
	160	--	160	2x DG	4x 30.0	4x 43.3	4x (3x 63)
180	--	180	2x DG	4x 33.8	4x 48.8	4x (3x 63)	
230V3 (230V/3~/50...60Hz)	5...8	5...8	5...8	EK	6.0	15.8	3x 20
	9...15	9...15	9...15	EK	11.3	29.6	3x 40
	16...21	16...21	16...21	EG	15.8	41.4	3x 50
	22...30	22...30	22...30	EG	22.5	59.1	3x 63
	44	44	44	DG	2x 16.5	2x 43.4	2x (3x 63)
	50	50	50	DG	2x 18.8	2x 49.3	2x (3x 63)
	60	60	60	DG	2x 22.5	2x 59.1	2x (3x 63)
	75	--	75	DG + EG	3x 18.8	3x 49.3	3x (3x 63)
	90	--	90	DG + EG	3x 22.5	3x 59.1	3x (3x 63)
	100	--	100	2x DG	4x 22.5	4x 59.1	4x (3x 63)
120	--	120	2x DG	4x 22.5	4x 59.1	4x (3x 63)	
230V1 (230V/1~/50...60Hz)	5	5	5	EK	3.8	16.3	20
	6...8	6...8	6...8	EK	6.0	26.1	35

** EK= Single unit small
EG= Single unit large
DG= Double unit large

Note: The minimum cross section of the supply cable must comply with the local regulations.

5.6.4 Inserting the CP3 Card

All important operating parameters such as the maximum steam capacity, the heating voltage, the number of base units as well as the differentiation between main and extension unit are permanently stored on the CP3 Card.

Before you start the electrical installation, **check whether the CP3 Card is installed**. If it is not, **check whether the type designation on the CP3 Card supplied corresponds with the type designation on the data plate on the bottom side of the unit (the data plate is located beside the type plate of the unit)**. If the designations match, place the CP3 Card in the card holder on control print. Then cover the data plate on the right side of the unit above the type plate with the data plate supplied (self-adhesive).

If the type designation on the CP3 Card and the data plate do not match, the CP3 Card must not be installed. If this is the case, contact your Condair supplier.

5.6.5 Notes on electric installation

- The electric installation must be carried out according to the wiring diagram in chapter 5.6.1 and the applicable local regulations. All information given in the wiring diagram must be followed and observed.
- All cables must be lead into the unit via the cable openings equipped with cable glands (e.g. option "PG-cable gland"). The cable for the heating voltage supply must be lead into the unit from the bottom via the cable opening equipped with the clamp strap. Fix the cable with the clamp strap.
- Make sure the cables do not scrub on any components.
- Maximum cable length and required cross section per wire must be observed.
- The supply voltages for heating and control must match the respective voltages stated in the wiring diagram.

5.6.6 Inspecting the electrical installation

Check the following points:

- Do the supply voltages for heating and control comply with the relevant voltages given in the wiring diagram?
- Is the correct CP3 Card inserted?
- Are the voltage supplies (heating and control voltage) correctly fused?
- Is the service switch "Q.." installed in the supply line for to the heating and control voltage?
- Are all components correctly connected according to the wiring diagram?
- Are all connecting cables fastened?
- Are the connecting cables free of tension (passed through cable glands?)
- Does the electric installation meet the applicable local regulations for electric installations?
- Is the front panel mounted and correctly fixed with the two screws?

6 Operation

6.1 Commissioning

Proceed as follows when putting the unit into operation:

1. **Examine the steam humidifier and installation for possible damage.**

 WARNING!	<p>Damaged devices or devices with damaged installation may present danger to human life or cause severe damage to material assets.</p> <p>Damaged units and/or units with damaged or faulty installation must not be operated.</p>
--	--

2. Check whether the front panel is mounted and fixed with the two screws.
3. Open the **filter valve** (or the shut-off valve, respectively) in the water supply line.
4. Verify the set humidity value at the humidity controller or at the humidistat, and readjust as required.
5. **Switch on the service switches** for mains supplies (heating and control voltage).
6. **Actuate the unit switch** of the steam humidifier. **Switch lights up.**

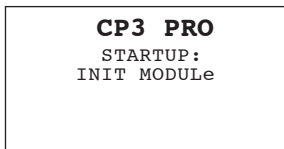

The steam humidifier carries out a **system test**, during which all the LEDs light up and the opposite display is shown.

If a failure occurs on the system test, a corresponding error message is shown in the display.

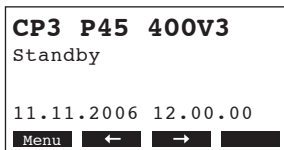

After the system test the unit is in **normal operation mode**. The display shows the **standard operating display** (first page of the indication level).

Note: The contents of the standard operating display depends on the actual operating status and on the configuration of the Condair CP3 and can differ from the opposite display.

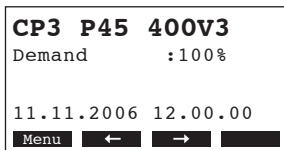

As soon as the humidity controller or the humidistat requires humidity, power is switched on for heating. The inlet valve opens (slight delay) and the steam cylinder fills with water. As soon as the submerged electrodes heat the water up the green LED lights up and after a few minutes (approx. 5–10 minutes, depending on the conductivity of the water) steam is produced.

Note: If the Condair CP3 is operated with water of low conductivity it may happen that the maximum steam capacity is not reached in the first few hours of operation. This is normal. As soon as the conductivity has reached a sufficient level (due to the vaporisation process) the humidifier will reach the maximum steam capacity.

6.2 Notes on operation

6.2.1 Function of the display and operating elements

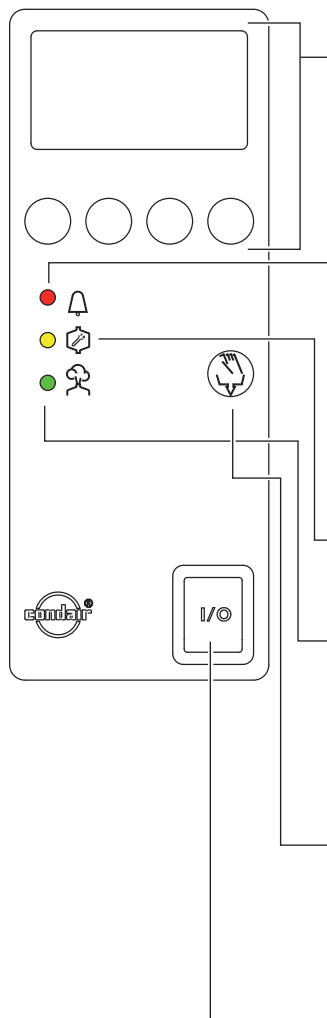

Display and control unit

Function: Configuration of the Condair CP3.
Indication of operating parameters.
Reset of maintenance counter and error indication.

red LED "Error"

Function: The LED lights in case of a malfunction of the unit. The type of malfunction is shown in the display, see chapter 8).
The LED flashes alternately with the green LED if the external safety chain (ventilation interlock, safety humidistat, etc.) is open.

yellow LED "Warning"

Function: The LED lights if the cylinder maintenance is due.

green LED "Steam"

Function: The LED lights if the unit produces steam.
The LED flashes alternately with the red LED if the external safety chain (ventilation interlock, safety humidistat, etc.) is open.

Drain key

Function: Manual draining of the steam cylinder. After having pressed the drain key, the draining is controlled via the display and control unit.

Unit switch

Function: Switches the unit on and off. The switch is illuminated when the unit is running.

6.2.2 Remote operating and fault indication

Via the operating and fault indication the following operating status are shown remotely:

Activated remote indication relay	When?	Display on unit
H1 "Error"	A malfunction is present, further operation is not possible, the heating voltage is interrupted	Red LED lights An error message is shown in the display
H2 "Service"	Steam cylinder maintenance is due. The unit remains operational for a certain time	Yellow LED lights The service warning message is shown in the display
H3 "Steam demand"	Steam demand/ Steam production	Green LED lights The standard operating display is shown.
H4 "Unit on"	Unit ready for operation	Unit switch lights The standard operating display is shown.

6.2.3 Inspections during operation

During operation the Condair CP3 and the humidification system have to be inspected weekly. On this occasion check the following:

- the water and steam installation for any leakage.
- the steam humidifier and the other system components for correct fixing and any damage.
- the electric installation for any damage.

If the inspection reveals any irregularities (e.g. leakage, error indication) or any damaged components take the Condair CP3 out of operation as described in chapter 6.3. Then, contact your Condair representative.

6.2.4 Carrying out manual draining

Proceed as follows to drain the unit manually:

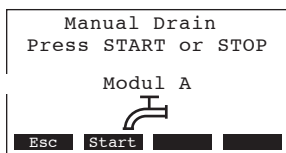

1. **Briefly press the drain key.** The drain dialogue appears in the display.
2. Press the **<Start>** key. The heating voltage is interrupted and the drain pump starts. The **yellow LED flashes**. To stop the drain cycle press the **<Stop>** key.

Note: By pressing the **<Esc>** key the unit returns to the indication level. A drain cycle in progress will be stopped automatically.

6.3 Taking the unit out of operation

In order to take the steam humidifier out of operation, perform the following steps:

1. If the unit has to be switched off because of a malfunction, please note the error code of the actual error message shown in the display.
2. Close the shut-off valve in the water supply line
3. Start manual draining (see chapter 6.2.4) and wait until the steam cylinder is empty.
4. **Actuate the unit switch**
5. **Disconnect steam humidifier from the mains:** Switch off all service switches to mains supplies (heating and control voltage) and secure switches in "off" position against accidentally being switched on, or clearly mark the switches.

 WARNING!	If steam was produced just before the unit is taken out of operation, wait before opening the unit and let the steam cylinder cool down to prevent danger of burning.
---------------------	--

6.4 Overview and operating of the menu

Operating

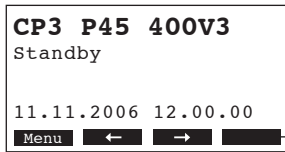

The operating and display unit is operated via the four keys located just below the display. The 4 status fields at the bottom of the display show the active keys the functions assigned to them.

actual key setting



keys

Menu overview

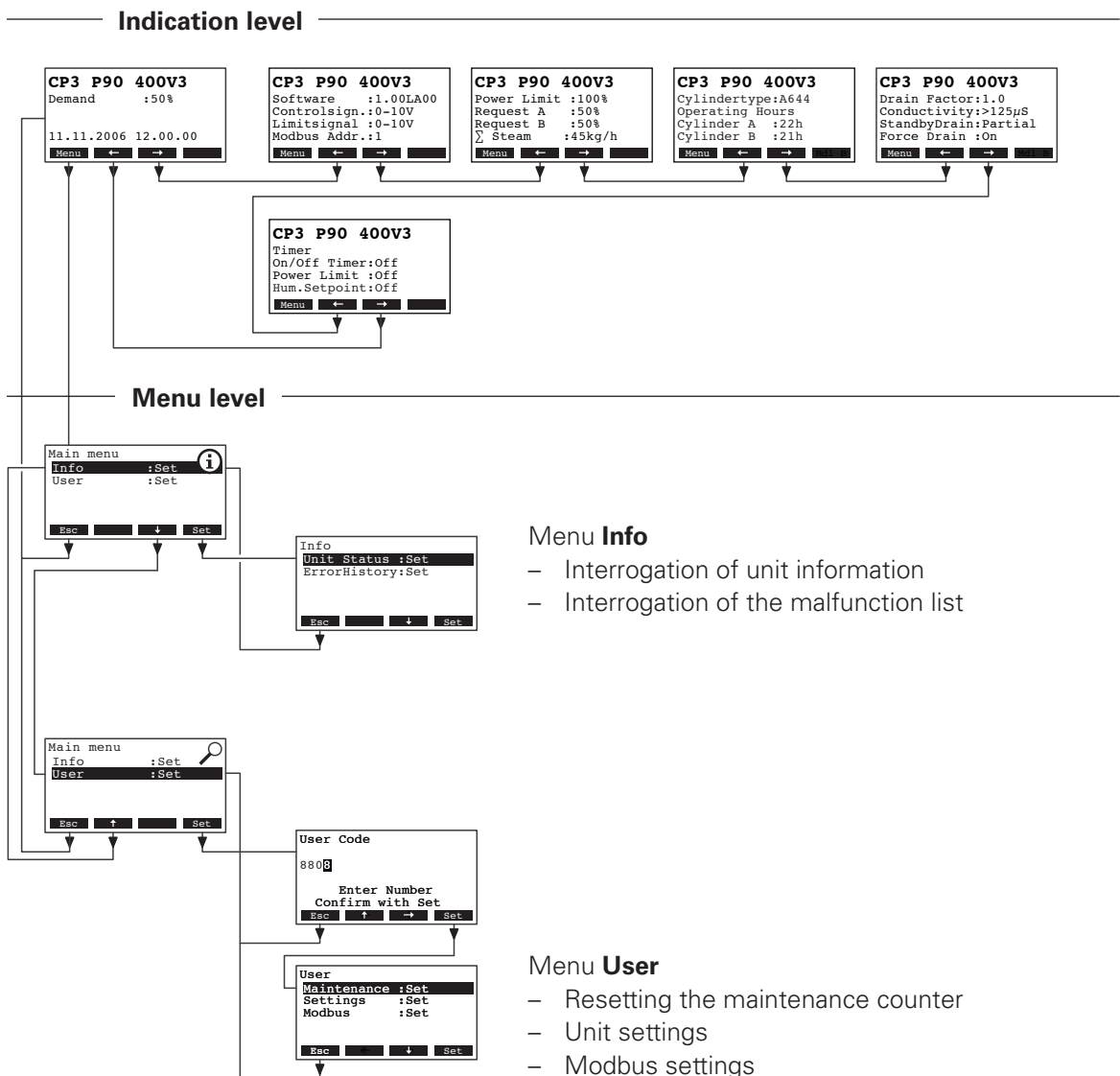

- Menu Info**
- Interrogation of unit information
 - Interrogation of the malfunction list

- Menu User**
- Resetting the maintenance counter
 - Unit settings
 - Modbus settings

6.5 Interrogation functions

6.5.1 Interrogation of the operating information in the indication level

In the normal operating mode the operating and display unit is in the indication level. The indication level forms a loop that includes several pages holding operating information which can be accessed with the arrow keys. The various displays of the indication level are shown below.

Standard operating display

The appearance of the standard operating display depends on the actual operating status and the configuration of the Condair CP3. The following displays are possible.

CP3 P90 400V3

Demand : 100%
Limiter : 70%

11.11.2006 12.00.00

Menu ← →

Standard operating display with control via the **external** controller

- Standby (no humidity demand) or Demand % (humidity demand present)
- Set supply air limitation in % *

* this parameter appears only if external supply air limitation is activated

CP3 P90 400V3

Act. Humidity: 75%rH
Hum. Setpoint: 50%rH
Lim. Humidity: 60%rH
Lim. Range : 70-90%

Menu ← →

Standard operating display with control via the **internal** controller

- Actual humidity in %rh
- Set nominal humidity %rh
- Set supply air limitation in % **
- Set range for supply air limitation in % **

** these parameters appear only if internal supply air limitation is activated

Info page: Settings

CP3 P90 400V3

Software : 1.00LA00
Control sign.: 0-10V
Limit signal : 0-10V
Modbus Addr.: 1

Menu ← →

- Software version (1.00)/language version (LA00)
- Set control signal range (signal Y)
- Set control signal range for the supply air limitation (signal Z). Appears only if supply air limitation is activated.
- Set Modbus address of the unit

Info page: Performance data

CP3 P90 400V3

Power Limit : 100%
Request A : 50%
Request B : 50%
∑ Steam : 45kg/h

Menu ← →

- Set power limitation in %
- Actual humidity demand unit A in %rh
- Actual humidity demand unit B in %rh (if present)
- Actual steam capacity of the unit in kg/h

Info page: Steam cylinder type and operating hours

CP3 P90 400V3

Cylindertype: A644
Operating Hours
Cylinder A : 20h
Cylinder B : 20h

Menu ← →

- Steam cylinder type
- Operating hours of the steam cylinder A since the last reset.
- Operating hours of the steam cylinder B since the last reset.

Info page: Drain settings

CP3 P90 400V3

Drain Factor: 1.0
Conductivity: >125µS
Standby Drain: Full
Forced Drain: Off

Menu ← →

- Set drain factor
- Conductivity of the water
- Set draining type in standby operation
- Set time interval for forced draining

Info Page: Timer settings

CP3 P90 400V3

Timer
On/Off Timer :Off
Power Limit :Off
Hum.Setpoint:Off

Menu ← →

- Actual status of On/Off timer
- Actual status of power limit timer
- Actual status of humidity setpoint timer (appears only if internal P/PI controller is activated)

6.5.2 Interrogation of unit information

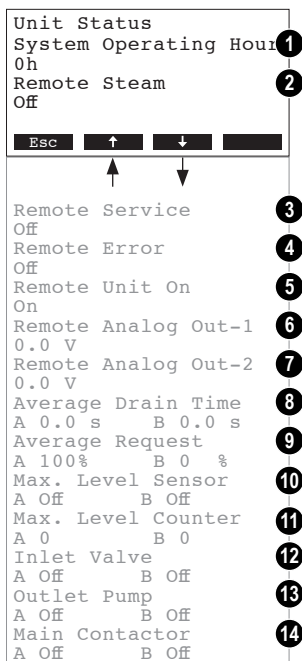

Select the list with the unit information:

Path: **Main menu > Info > Unit Status**

Press **<↓>** and **<↑>** keys, in order to select the unit information available in the list:

- 1 Total operating hours since the initial commissioning.
- 2 Actual status of the remote indication relay "Steam"
- 3 Actual status of the remote indication relay "Service"
- 4 Actual status of the remote indication relay "Error"
- 5 Actual status of the remote indication relay "Unit on"
- 6 Actual signal value at analog output 1 (corresponds to the actual steam capacity converted to the signal range of 0...10 V)
- 7 Actual signal value at analog output 2 (0...10V)
- 8 Calculated mean drain time in seconds of unit A (and B)
- 9 Current average request of unit A (and B)
- 10 Actual status of the maximum level sensor in the steam cylinder A (and B)
- 11 Counter showing the number of times the maximum level in the steam cylinder A (and B) has been exceeded
- 12 Actual status of the inlet valve of unit A (and B)
- 13 Actual status of the drain pump of unit A (and B)
- 14 Actual status of the main contactor of unit A (and B)

Press the **<Esc>** key several times to quit the unit information list and to return to the standard operating display.

6.5.3 Interrogation of the malfunction list

The error messages generated by the last 20 malfunctions that occurred are saved in the malfunction list of the Condair CP3 and can be interrogated.

```
ErrorHistory
01/05 11.11.06 12.34
E32A HumSensor broken
No sensor signal
Humidity sensor def.
Esc  →  Set
```

Select the error history list:

Path: **Main menu > Info > ErrorHistory**

The last error that occurred is shown with:

- running number of the error
- date and time of occurrence (version Pro only)
- error code (Warning: W..., Error: E...)
- error message
- additional info text regarding the error

Press **<↓>** and **<↑>** keys, in order to select further error messages in the list.

Press the **<Esc>** key several times to quit the error history list and to return to the standard operating display.

6.6 Unit settings

6.6.1 Launching the unit settings menu

```

Settings
Language :English
Controls :Set
Cylinder :Set
Power Limit :Set
On/Off Timer:Set
Esc  ↓  Set
      ↑
GFCI-Mode :Off
Multi-Mode :Sequence
Water Manag.:Set
Remote Test :Set
Date :19.10.07
Time :12:00
Contrast :15

```

Select the unit settings menu:

Path: **Main menu > User > Password entry: 8808 > Settings**

Press the <↓> and <↑> keys in order to select the individual settings in the settings menu.

Detailed information on the different settings are found in the following chapters.

6.6.2 Selecting the dialogue language

```

Settings
Language :English
Controls :Set
Cylinder :Set
Power Limit :Set
On/Off Timer:Set
Esc  ↓  Set

```

Select “**Language**” in the settings menu, then press the <Set> key.

In the upcoming modification dialogue select the desired dialogue language. After confirmation, the unit automatically switches to the selected dialogue language.

Factory setting:

country specific

Options:

divers languages

6.6.3 Control settings

```

Settings
Language :English
Controls :Set
Cylinder :Set
Power Limit :Set
On/Off Timer:Set
Esc  ↑  ↓  Set

```

Select “**Controls**” in the settings menu, then press the <Set> key.

```

Controls
SignalSource:Analog
Hum.Control :Int. (PI)
Controlsign.:0-10V
Hum.Setpoint:Set
P-Band :18%rH
Esc  ↑  ↓  Set
      ↑  ↓
Integr.-Time:8min
Lim. Control:On
Limitsignal :0-10V
Limit Min :70%rH
Limit Max :90%rH

```

The control settings appear. The settings available depend on the selected signal source and the control type. The opposite display shows the maximum number of settings available.

Description of the control settings

- **SignalSource:** Selecting the signal source.
 Factory setting: **Analog**
 Options: **Analog, Modbus**
- **Hum. Control:** Selecting the control type.
 Factory setting: **Extern**
 Options: **Extern** (external continuous controller),
24VOn/Off (external On/Off humidistat),
Int. (P) (Internal P controller)
Int. (PI) (Internal PI controller)

- **Controlsign.:** Selecting the control signal.
Note: This setting is available only if the internal or external P or PI controller is activated.

Factory setting: **0–10V**
Options: **0–5V, 1–5V, 0–10V, 2–10V, 0–16V, 3.2–16V, 0–20mA, 4–20mA**

- **Hum.Setpoint:** This menu item is available only if the internal P or PI controller is activated. With the parameters in the “Hum.Setpoint” submenu you determine whether the Condair CP3 is to be controlled with a fix humidity setpoint (factory setting) or whether it is to be operated timer controlled with different humidity setpoints.

- Control with **fix humidity setpoint:**

```
Hum.Setpoint
Timer        : Off
Hum.Setpoint: 50%rH
Esc        [  ]  [  ]  [  ]  [  ]  [  ]
Set
```

Timer deactivated, humidity setpoint adjustable (factory setting: 50 %rH, Setting range: 15...95 %rH)

- **Timer controlled with different humidity setpoints:**

```
Hum.Setpoint
Timer        : On
Event 1      : 06:00
Event 2      : 18:00
Event 3      : --:--
Event 4      : --:--
Esc        [  ]  [  ]  [  ]  [  ]  [  ]
Set
```

If the timer is activated, up to eight switching points (events 1 - 8) with different humidity setpoints can be defined.

```
Event 2
Weekday      : Mo-Fr
Time         : 18:00
Hum.Setpoint : 30%rH
Esc        [  ]  [  ]  [  ]  [  ]  [  ]
Set
```

Each switching point is defined by a weekday or weekday range, the switching point and the humidity setpoint.

Configuration notes:

- the settings of an event remain active up to the next event.
 - the software does not check the plausibility of the timer settings. Therefore, make sure your settings make sense.
 - the On/Off timer (see chapter 6.6.6) overrides the humidity setpoint timer.
- **P-Band:** Setting the proportional range in % for the internal P/PI controller.
Note: This setting is available only if the internal P or PI controller is activated.
Factory setting: **18 %**
Setting range: **6...65 %**
 - **Integr.-Time:** Setting the integral time in minutes for the internal PI controller.
Note: This setting is available only if the internal PI controller is activated.
Factory setting: **8 minutes**
Setting range: **1...60 minutes**
 - **Lim. Control:** Activating/Deactivating the **supply air limitation (signal Z)**.
Note: This setting is available only if the external or internal P or PI controller is activated.
Factory setting: **Off**
Options: **On, Off**

- **Limitsignal:** Selecting the supply air **limitation signal**.
 Note: This setting is available only if the external or internal P or PI controller and the supply air limitation are activated.
 Factory setting: **0–10V**
 Options: **0–5V, 1–5V, 0–10V, 2–10V, 0–16V, 3.2–16V, 0–20mA, 4–20mA**
- **Limit Min:** Setting the lower limit value in %rh for the supply air limitation.
 Note: This setting is available only if the **internal** P or PI controller and the and the supply air limitation are activated.
 Factory setting: **70 %rh**
 Setting range: **15 ... 95 %rh**
- **Limit Max:** Setting the upper limit value in %rh for the supply air limitation.
 Note: This setting is available only if the internal P or PI controller and the and the supply air limitation are activated.
 Factory setting: **90 %rh**
 Setting range: **15 ... 95 %rh**

6.6.4 Cylinder settings

```
Settings
Language      :English
Controls      :Set
Cylinder      :Set
Power Limit   :Set
On/Off Timer:Set
Esc  ↑      ↓  Set
```

Select "**Cylinder**" in the settings menu, then press the **<Set>** key.

```
Cylinder
Cyl. Line     :Dispos
Cyl. Number   :644
Esc  █      ↓  Set
```

The cylinder settings appear. Press the **<↕>** and **<↑>** keys in order to select the individual settings and press the **<Set>** key to call up the modification dialogue for the selected setting.

Description of the cylinder settings

- **Cyl. Line:** Selecting the cylinder type.
 Factory setting: **Dispos**
 Options: **Dispos** (Disposable cylinder A..)
 Clean (Cleanable cylinder D..)
- **Cyl. Number:** Selecting the cylinder number
 Factory setting: **according the installed cylinder**
 Options: **342, 343, 363, 444, 464, 654, 644, 664, 674**

6.6.5 Setting the capacity limitation

```

Settings
Controls      :Set
Cylinder      :Set
Power Limit   :Set
On/Off Timer :Set
GFCI-Mode    :Off
Esc  ↑      ↓  Set

```

Select "**Power Limit**" in the settings menu, then press the **<Set>** key. With the parameters in the "Power Limit" submenu you determine whether the Condair CP3 is to be operated with a fix capacity limit (factory setting) or whether it is to be operated with a timer controlled capacity limitation.

Note: set the desired capacity limitation **in % of the maximum capacity** of the humidifier.

- Operation with **fix capacity limit**:

```

Power Limit
Timer      :Off
Power Limit :100%
Esc  ↓      Set

```

Timer deactivated, capacity limit adjustable (factory setting: 100 %, Setting range: 30...100 %).

- **Timer controlled capacity limitation**:

```

Power Limit
Timer      :On
Event 1    :06:00
Event 2    :18:00
Event 3    :--:--
Event 4    :--:--
Esc  ↓      Set

```

If the timer is activated, up to eight switching points (events 1 - 8) with different capacity limits can be defined.

```

Event 2
Weekday    :Mo-Fr
Time       :18:00
Power Limit :50%
Esc  ↓      Set

```

Each switching point is defined by a weekday or weekday range, the switching point and the capacity limit.

Configuration notes:

- the settings of an event remain active up to the next event.
- the software does not check the plausibility of the timer settings. Therefore, make sure your settings make sense.
- the On/Off timer (see chapter 6.6.6) overrides the capacity limit timer.

6.6.6 Configuring the On/Off timer

```

Settings
Cylinder      :Set
Power Limit   :Set
On/Off Timer: Set
GFCI-Mode    :Off
Multi-Mode    :Sequence
Esc  ↑      ↓  Set

```

Select “**On/Off Timer**” in the settings menu, then press the **<Set>** key. With the parameters in the “On/Off Timer” submenu you determine whether or not the Condair CP3 is to be switched on and off timer controlled.

- On/Off timer **deactivated**:

```

On/Off Timer
Timer         : Off
Esc          ↓  Set

```

- On/Off timer **activated**:

```

On/Off Timer
Timer         : On
Event 1       : 06:00
Event 2       : 22:00
Event 3       : --:--
Event 4       : --:--
Esc          ↓  Set

```

If the timer is activated, up to eight switching points (events 1 -8) with different On/Off events can be defined.

```

Event 2
Weekday       : Mo-Fr
Time          : 22:00
Mode          : On
Esc          ↓  Set

```

Each switching point is defined by a weekday or weekday range, the switching point and the operating mode.

Configuration notes:

- the settings of an event remain active up to the next event.
- the software does not check the plausibility of the timer settings. Therefore, make sure your settings make sense.
- the On/Off timer overrides all other timers.

6.6.7 Activating/Deactivating fault current relay operation

```

Settings
Power Limit   :Set
On/Off Timer: Set
GFCI-Mode    :Off
Multi-Mode    :Sequence
Water Manag.: Set
Esc  ↑      ↓  Set

```

Select “**GFCI-Mode**” in the settings menu, then press the **<Set>** key. In the upcoming modification dialogue select whether or not the Condair CP3 is connected to a fault current relay protected mains supply.

Factory setting:

Off

Options:

On (mains supply with fault current relay protection)

Off (mains supply without fault current relay protection)

6.6.8 Setting the operation mode for multiple units

Note: This setting is available only on main module A of multiple units.

```
Settings
On/Off Timer:Set
GFCI-Mode :Off
Multi-Mode :Sequence
Water Manag.:Set
Remote Test :Set
Esc ↑ ↓ Set
```

Select "**Multi-Mode**" in the settings menu, then press the **<Set>** key. In the upcoming modification dialogue you determine how the demanded steam capacity is shared among the units.

Factory setting: **Sequence**
Options: **Sequence** (sequential load sharing)
 Parallel (even load sharing)

6.6.9 Water management settings

```
Settings
GFCI-Mode :Off
Multi-Mode :Sequence
Water Manag.:Set
Remote Test :Set
Date :19.10.07
Esc ↑ ↓ Set
```

Select "**Water Manag.**" in the settings menu, then press the **<Set>** key.

```
Water Manag.
Conductivity:>125µS
Drain Factor:1.0
StandbyDrain:Full
StandbyDelay:72h
Force Drain :On
Esc ↑ ↓ Set
```

↑ ↓

```
Force Delay :72h
```

The water management settings menu appears.

Press the **<↓>** and **<↑>** keys in order to select the individual settings and press the **<Set>** key to call up the modification dialogue for the selected setting.

Description of the water management settings

- **Conductivity:** Selecting the conductivity range of the supply water.
Factory setting: **>125 µS/cm**
Options: **>125 µS/cm, <125 µS/cm**
 - **Drain Factor:** Setting the drain factor
Factory setting: **1.0**
Setting range: **0.5...2.0**
 - **StandbyDrain:** Selecting the type of draining which takes place after a certain time (see following setting) of **standby operation**.
Factory setting: **Full**
Options: **Full** (complete draining)
 Partial (partial draining) **
 Off (draining deactivated)
- ** The cylinder is drained so far that the water does not touch the electrodes any longer.
- **StandbyDelay:** Setting the period of time in standby operation after which an automatic cylinder draining takes place.
Factory setting: **72 hours**
Setting range: **1...720 hours**

- **Force Drain:** Activating/Deactivating the forced draining which takes place after a certain time of operation. The forced draining takes place also during steam production.
Factory setting: **Off**
Options: **On** (Forced draining activated)
Off (Forced draining deactivated)
- **Force Delay:** Setting the time of operation after which a forced draining takes place.
Factory setting: **72 hours**
Setting range: **1...720 hours**

6.6.10 Performing remote relay tests

```
Settings
Multi-Mode :Sequence
Water Manag.:Set
Remote Test :Set
Date       :19.10.07
Time       :12:00
Esc  ↑   ↓   Set
```

Select "**Remote Test**" in the settings menu, then press the **<Set>** key.

```
Remote Test
Remote Steam:
Off
Esc  ↑   ↓   Set
↑   ↓
Remote Service
Off
Remote Error
Off
Remote Unit On
On
Remote Analog Out-1
0.0 V
Remote Analog Out-2
0.0 V
```

The list with the remote relay tests appears, the first relay test is shown.

Press the **<↓>** and **<↑>** keys in order to select the further relay tests available and press the **<Set>** key to activate/deactivate the corresponding relay for testing.

6.6.11 Setting the date

```
Settings
Water Manag.:Set
Remote Test :Set
Date       :19.10.07
Time       :12:00
Contrast   :15
Esc  ↑   ↓   Set
```

Select "**Date**" in the settings menu, then press the **<Set>** key. In the upcoming modification dialogue set the actual date (format:"dd.mm.yy").

6.6.12 Setting the time

```
Settings
Water Manag.:Set
Remote Test :Set
Date       :19.10.07
Time       :12:00
Contrast   :15
Esc  ↑   ↓   Set
```

Select "**Time**" in the settings menu, then press the **<Set>** key. In the upcoming modification dialogue set the actual time (format:"hh.mm").

6.6.13 Setting the display contrast

```

Settings
Water Manag.:Set
Remote Test :Set
Date       :19.10.07
Time       :12:00
Contrast   :15
Esc  ↑      Set

```

Select "**Contrast**" in the settings menu, then press the **<Set>** key. In the upcoming modification dialogue set the desired value for the display contrast.

Factory setting: **15**
 Setting range: **0** (no display) ...**100** (display turns black)

6.7 Modbus settings

```

Modbus
Modbus Addr.:1
Parity       :none
Timeout      :5s
Esc  ↑      Set

```

Select the Modbus menu:

Path: **Main menu > User > Password entry: 8808 > Modbus**

The settings for the Modbus appear.

Description of the Modbus settings

- **Modbus Addr.:** Setting the modbus address of the Condair CP3.
 Factory setting: **1**
 Setting range: **1...247**
- **Parity:** Selecting the parity bit for the data transmission
 Factory setting: **None**
 Options: **None, Odd, Even**
- **Timeout:** Setting the time out time for the data transmission.
 Factory setting: **5 Seconds**
 Setting range: **1...600 Seconds**

7 Maintenance

7.1 Important notes on maintenance

Qualification of personnel

All maintenance work must be carried out only by **well qualified and trained personnel authorised by the owner**. It is the owner's responsibility to verify proper qualification of the personnel.

General note

The instructions and details for maintenance work must be followed and upheld.

Only the maintenance work described in this documentation may be carried out.

Only use original Condair spare parts to replace faulty parts.

Safety

Some maintenance work requires removal of the unit cover. Please note the following:

 WARNING!	Danger of electrical shock! You may get in touch with live parts when the unit is open. Touching live parts may cause severe injury or even lethal violation.
--	--

Prevention: Before carrying out any maintenance work set the Condair CP3 out of operation as described in chapter 6.3 (switch off the unit, disconnect it from the mains and stop the water supply) and secure the unit against inadvertent power-up.

CAUTION!	The electronic components inside the humidifier are very sensitive to electrostatic discharge .
-----------------	---

Prevention: Before carrying out any maintenance work to the electrical or electronic equipment of the humidifier, appropriate **measures must be taken to protect the respective components against damage caused by electrostatic discharge (ESD protection)**.

7.2 Maintenance list

To maintain operational safety the Condair CP3 steam humidifier must be maintained at regular intervals. This is differentiated between the **first maintenance after approx. 500 operating hours (I)**, **steam cylinder maintenance after the yellow LED lights (II)** and **annual maintenance (III)**.

Below you will find a summary of the work to be carried out for each of the three maintenance stages.

Components	Interval			Work to be done
	I	II	III	
Cleanable steam cylinder Type D..	X	X	X	Clean steam cylinder and electrodes and check for damage, replace if necessary. Note: The steam cylinder must be replaced after a maximum operating time of 5,000 h.
Electrode plug	X	X	X	Check to see firmly positioned (remove cover and tighten fixing screw with hexagonal head socket wrench). Warning! This work should only be carried out by an electrician.
Replacement steam cyl. type A..		X		Remove and replace.
Drain pump			X	Remove, disassemble and clean, replace if necessary.
Steam cylinder receptacle			X	Inspect, clean if necessary.
Inlet valve			X	Remove and clean filter insert, replace if necessary.
Drain pipe and siphon			X	Inspect, clean if necessary (decalcify and rinse out).
Steam installation	X		X	Inspect steam and condensate hoses for cracks and to see that they are correctly attached, replace faulty hoses.
Water installation	X		X	Inspect water hoses in the unit for cracks and to see that they are correctly attached, replace faulty hoses Check supply pipe is tight, make tight if necessary. Clean water filter, if available.
Electrical installation	X		X	Check all cables in the unit are firmly positioned and examine status of insulation.

7.3 Removing and installing parts for maintenance

7.3.1 Removal and installation of the steam cylinder

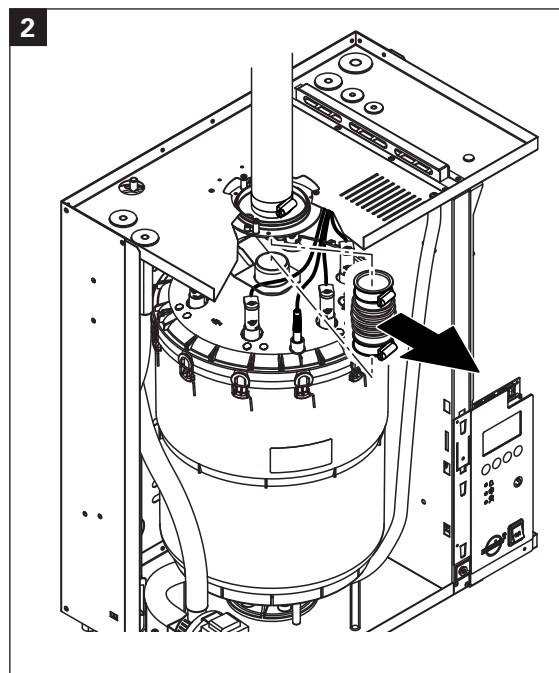
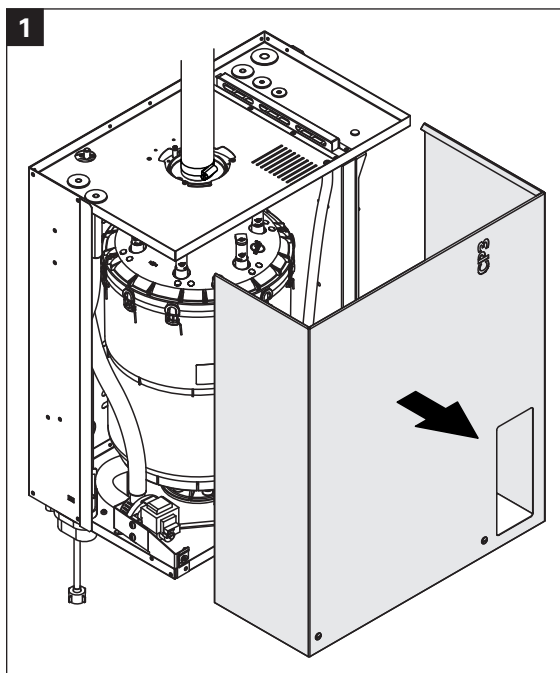

1. Use a screwdriver to undo the two screws fixing the front panel to the unit, then remove the front panel.
2. **Units with steam hose connector in housing top:** release the two hose clamps on the rubber sleeve using a screwdriver, then detach the rubber sleeve from the connection in the unit cover and from the steam outlet connection of the steam cylinder.

Units without steam hose connector in housing top (not shown): release the hose clamp on the steam hose using a screwdriver, then detach the steam hose from the steam outlet connection of the steam cylinder.

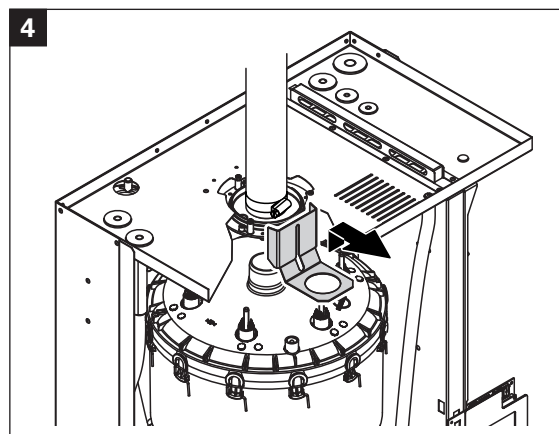
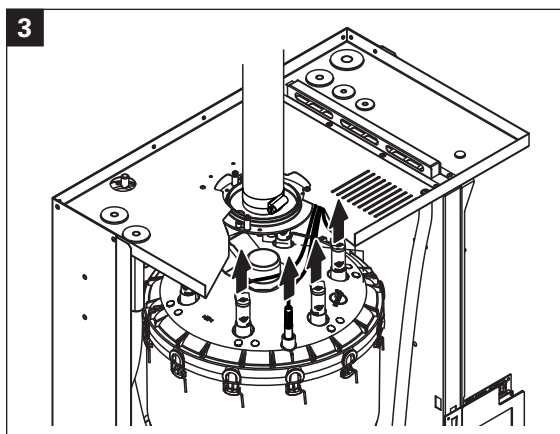

3. Remove all plugs from the electrodes and from the level sensor.
4. Loosen the two screws of the steam cylinder fixing device by a few turns, then push the fixing device upwards until it comes loose and remove it.

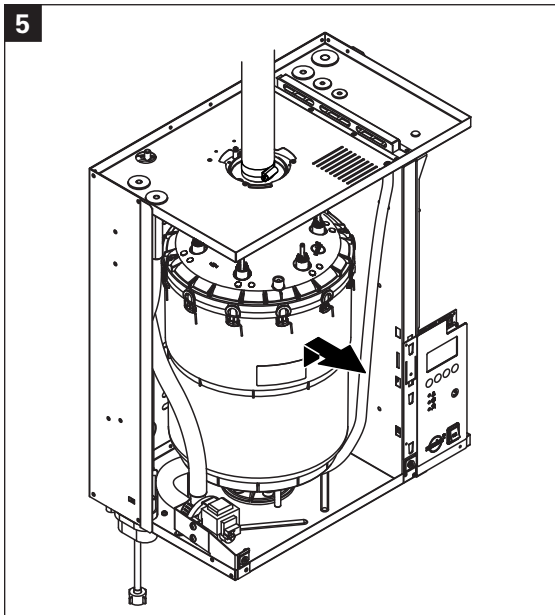

5. Carefully lift steam cylinder away from the cylinder receptacle, then remove it to the front.

CAUTION!

Put steam cylinder down carefully to avoid damage to the lower connection piece!

Installation of the steam cylinder follows the reverse sequence. **Observe the following:**

- Before installing the steam cylinder in the unit, check the O-ring of the cylinder receptacle for damage and replace if necessary.
- Moisten the O-ring of the cylinder receptacle with water (do not use grease or oil), then insert steam cylinder into the receptacle and push it down to the stop.
- Attach the electrode plugs and the level sensor plug to the respective electrode and sensor connections according to the following table.

	Steam cylinder type	
	A363 / D363 A464 / D464	A664 / D664 A674 / D674
Cable configuration		

- Fasten steam hose on the connector in the unit cover and on steam connector of the cylinder with hose clamps.

CAUTION!

A leaky steam hose can cause damage due to moisture inside the unit.

CAUTION!

The outlet connector of the steam cylinder is made of plastic. **Do not overtighten** the hose clamp on the steam connector of the steam cylinder.

7.3.2 Disassembly and assembly of the cleanable steam cylinder type D...

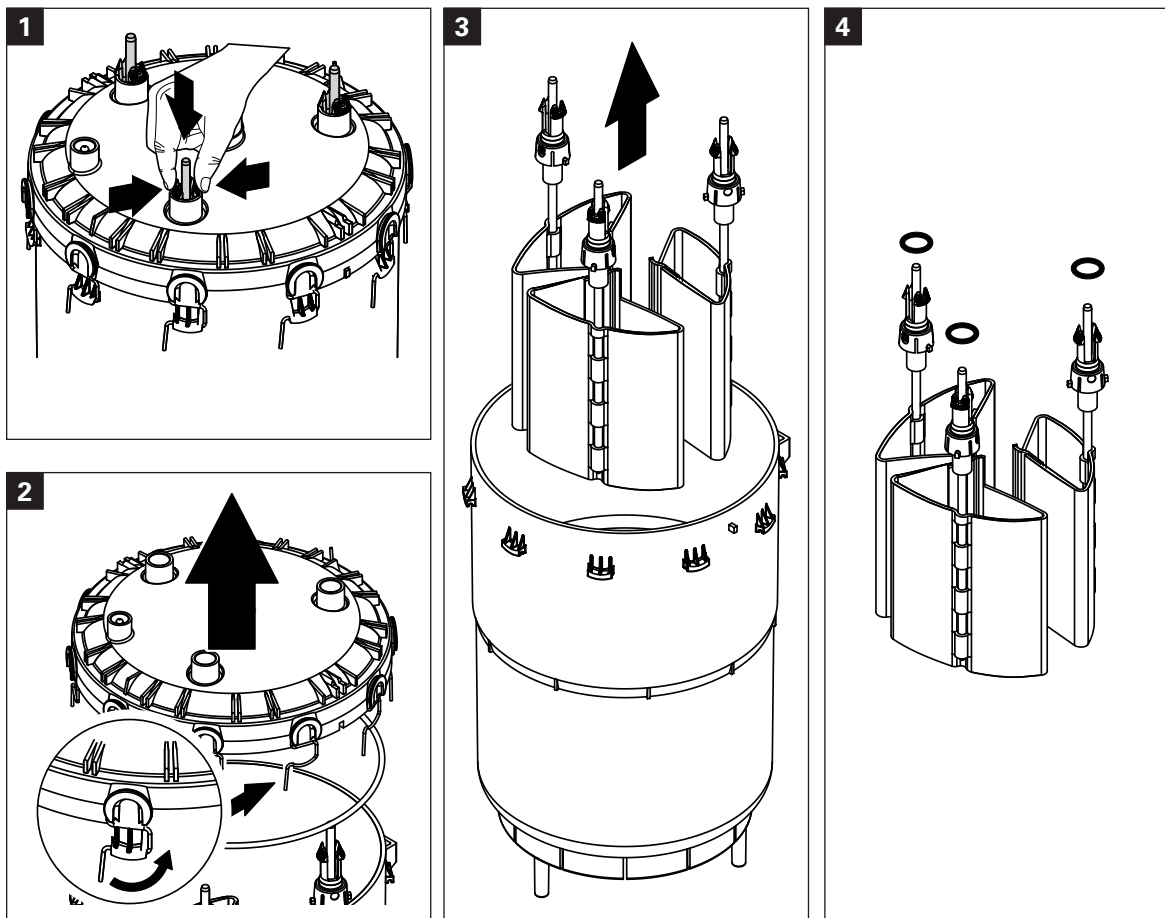

1. Fasten electrode snap fastenings and push electrodes approx. 2 cm downwards into the steam cylinder.
2. Release clamp clips of the cylinder cover and raise cover.
3. Remove carefully electrodes by lifting upwards.
4. Remove O-rings from the electrodes.
Note: Intact O-rings can be reused.

The **assembly** of the cleanable steam cylinder follows the reverse sequence. **Observe the following:**

- Before assembling the steam cylinder, check the O-ring in the steam cylinder cover and the O-rings on the electrodes for damage, and replace if necessary. Make sure to relocate O-rings correctly.
- Insert electrodes into steam cylinder cover and push them upwards until the snap fasteners engage.
- Place the cylinder cover (with mounted O-ring) in the correct position (align the two cams on the steam cylinder body with the corresponding grooves in the cylinder cover) on the cylinder body and secure cover with the fastening clips.

7.3.3 Removal and installation of the water cup and the water hoses

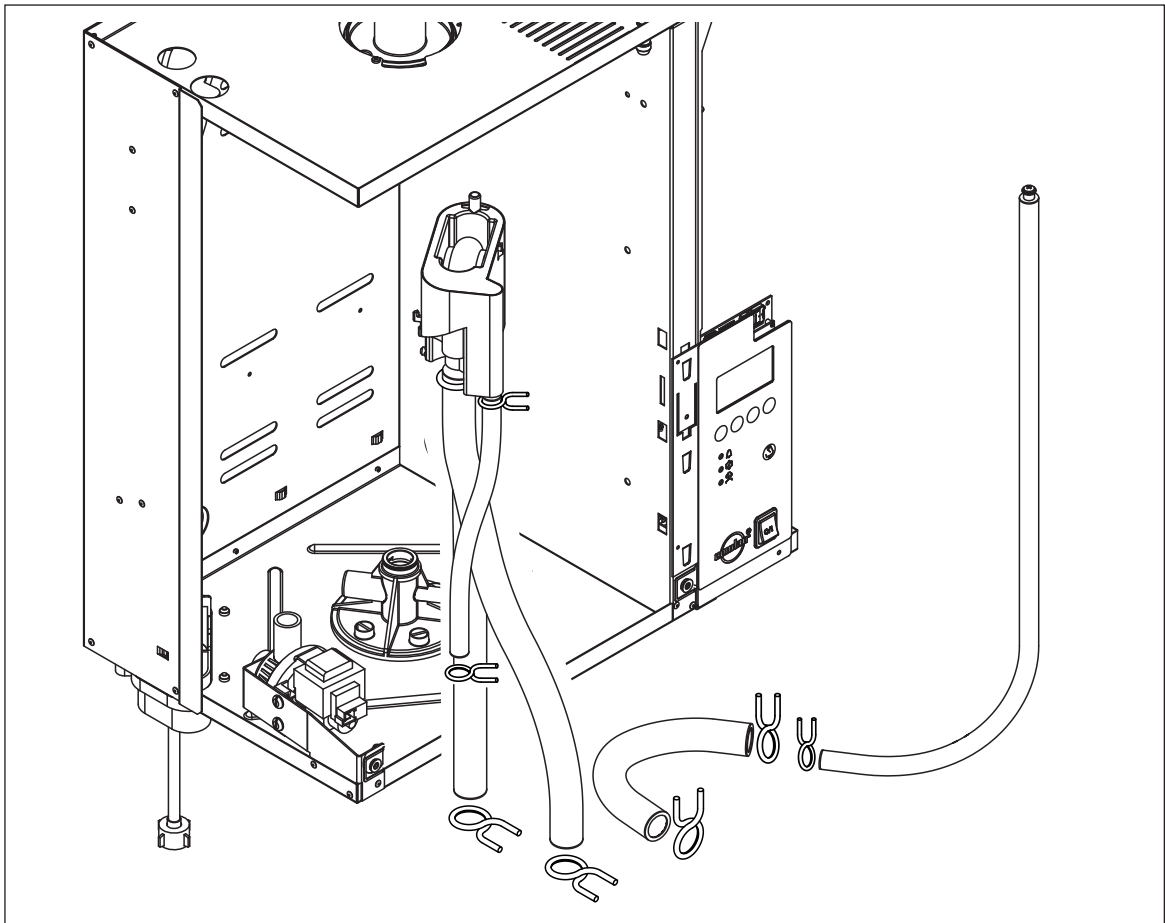

To improve accessibility for removing the water cup and the water hoses we recommend to remove the steam cylinder first (see chapter 7.3.1).

1. Release hose clamps using pliers, then disconnect all hoses from the corresponding connectors and remove the hoses.
Note: The hoses connected to the water cup may also be removed together with the water cup (see illustration) and then disconnected from the connectors of the water cup outside the unit.
2. **Carefully** pull fixing clip of the water cup to the front, then push water cup down from the holding device and remove it to the front.

The **installation** of the water cup and the water hoses follows the reverse sequence. Before fixing the water hoses to the connector using the hose clamps, align the hoses in a way that they are not twisted.

7.3.4 Removal and installation of the drain pump

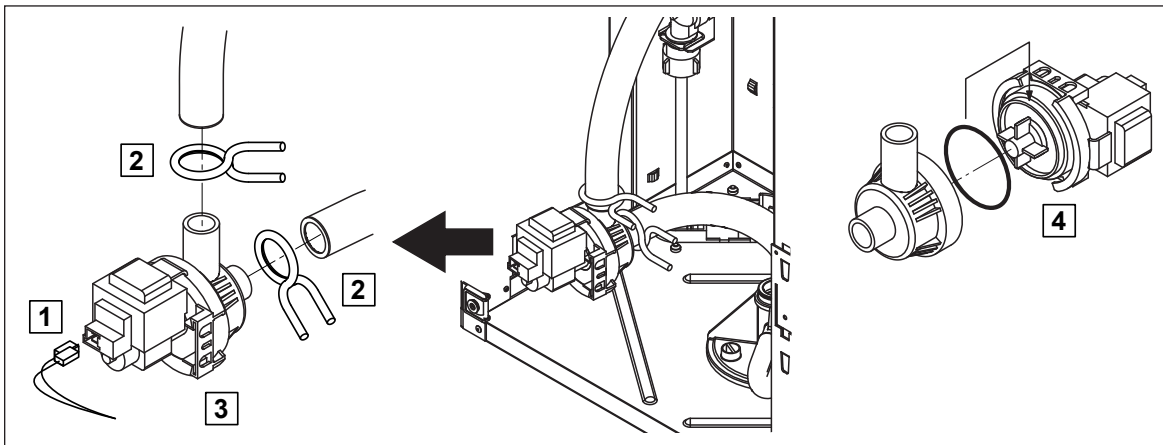

The steam cylinder does not need to be removed when removing the drain pump.

1. Detach electric cables (polarity of the cables must not be observed).
2. Release hose clamps and remove the hoses from the connectors.
3. Pull the drain pump off the holding device.
4. Separate the electric motor from the pump body: release the lock on the bayonet catch, then counter-rotate the electric motor and the pump body.

The **assembly** and the **installation** of the drain pump follows the reverse sequence. Before assembling the pump, check O-ring for damage and replace if necessary. Then, place the O-ring on the centering collar and moisten the O-ring with water.

7.3.5 Removal and installation of the inlet valve

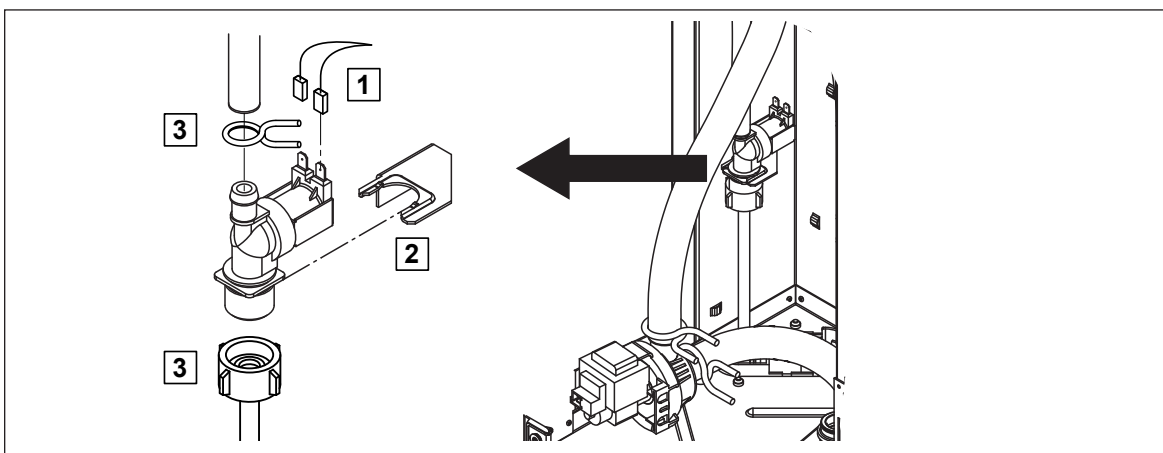





The steam cylinder does not need to be removed when removing the inlet valve.

1. Detach electric cables (polarity of the cables must not be observed).
2. Release hose clamp and remove the hose from the connector.
3. Unlock union nut of the water pipe and remove water pipe.
4. Pull the inlet valve off the holding device.

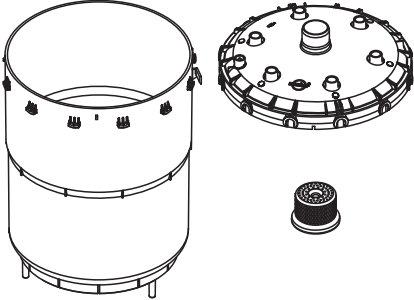
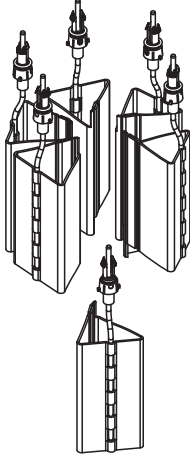
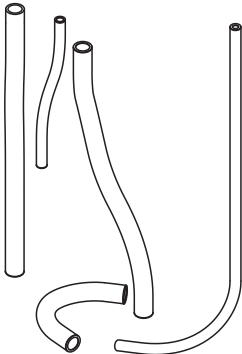
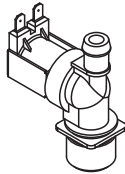
The **installation** of the inlet valve follows the reverse sequence. The union nut of the water pipe must be tightened by hand only.

7.4 Notes on cleaning the unit components

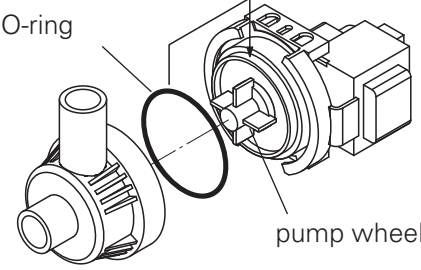
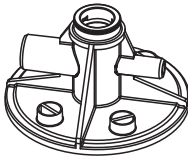
Unit component	What to clean and how to clean
<p>Steam cylinder cover Steam cylinder body Cylinder strainer</p> 	<ul style="list-style-type: none"> • Knock off or brush away any limescale as much as possible (do not use a wire brush). If the parts are heavily calcified, place them in an 8% formic acid solution (observe safety notes in chapter 7.5), until the limescale comes off. • Finally wash parts in a lukewarm soap solution and rinse well with tap water.
<p>Heating electrodes</p> 	<ul style="list-style-type: none"> • Immerse the heating electrodes (up to 2 cm below the snap fastening) in a container with 8-percent formic acid (observe safety notes in chapter 7.5). Allow the acid to take effect until the limescale has dissolved. Note: The heating elements do not have to be entirely free from scale. • Finally rinse the heating electrodes well with tap water and let them dry. <div data-bbox="786 1070 1430 1216" style="border: 1px solid black; padding: 5px;"> <p>CAUTION! On no account remove limescale from the heating electrodes using tools (screwdriver, scraper, etc.) or by striking. This could damage the heating elements.</p> </div>
<p>Water hoses</p> 	<ul style="list-style-type: none"> • Remove any limescale by slightly knocking on the tubes using a rubber hammer. Then, rinse the tubes well with hot tap water.
<p>Inlet valve</p>  <p>Strainer insert </p>	<ul style="list-style-type: none"> • Remove strainer insert with pointed pliers. Use a brush (do not use a wire brush) to remove any limescale. • Wash strainer insert with a lukewarm soap solution, then rinse well with tap water. <p>Let the inlet valve dry before reinstallation!</p>

Unit component	What to clean and how to clean		
<p>Drain pump</p>  <p>O-ring</p> <p>pump wheel</p>	<ul style="list-style-type: none"> • Use a brush to remove any limescale from the pump housing and the pump wheel (do not use a wire brush). • Then, wipe pump wheel with a damp cloth. Wash the pump housing with a lukewarm soap solution and rinse well with tap water. 		
<p>Cylinder receptacle in the unit</p> 	<ul style="list-style-type: none"> • Remove any limescale from the cylinder receptacle and its connectors using a brush (do not use a wire brush). • Wash the cylinder receptacle with a lukewarm soap solution and rinse well with tap water. 		
<p>Water cup</p> 	<ul style="list-style-type: none"> • Remove any limescale from the water cup and its connectors using a brush (do not use a wire brush). • Wash the water cup with a lukewarm soap solution and rinse well with tap water. 		
<p>Interior of the unit (water side only)</p>	<p>Wipe the interior of the unit with a damp cloth without using any cleaning agent.</p> <table border="1" data-bbox="751 1310 1433 1384"> <tr> <td data-bbox="751 1310 900 1384">CAUTION!</td> <td data-bbox="903 1310 1433 1384">Take care that the electrical connections and the electronic components remain dry.</td> </tr> </table>	CAUTION!	Take care that the electrical connections and the electronic components remain dry.
CAUTION!	Take care that the electrical connections and the electronic components remain dry.		

7.5 Notes on cleaning agents

Only use cleaning agents stated in the table above. The use of disinfectants is only permitted if they do not leave any toxic residues. In any case the parts must be thoroughly rinsed with water after cleaning.

 WARNING!	<p>Formic acid is indeed harmless to the skin, but it attacks the mucous membranes. Therefore prevent your eyes and respiratory tracts from getting in touch with the acid and its vapours (wear goggles and work in a well ventilated room or outside).</p>
CAUTION!	<p>Do not use any solvents, aromatized or halogenized hydrocarbons or other aggressive substances as they may cause damage to the components of the unit.</p>

It is mandatory to observe and comply with the information and instructions regarding cleaning agents. Observe in particular: all information relating to the protection of personnel, environmental protection and restrictions regarding usage.

7.6 Resetting the maintenance indication

After completing maintenance work, the **maintenance indication** (yellow LED lights) must be reset as follows:

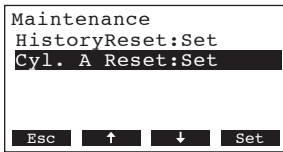

Select the maintenance menu:

Path: **Main menu > User > Password entry: 8808 >**

Select "**Cyl. A Reset**" (or "**Cyl. B Reset**") in the maintenance menu, then press the **<Set>** key.

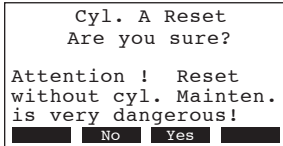

The reset dialogue shows up in the display. Press the **<Yes>** key to reset the **maintenance counter**.

Note: Press the **<No>** key if you wish to abort the reset procedure.

To return to the standard operating display press the **<Esc>** key several times.

8 Malfunctions

Important! Most operational malfunctions are not caused by faulty equipment but rather by improper installation or disregarding of planning guidelines. Therefore, a complete fault diagnosis always involves a thorough examination of the entire system. Often, the steam hose connection has not been properly executed, or the fault lies with the humidity control system.

8.1 Malfunction list

8.1.1 System faults

Warning		Error		Cause	Remedy
LED	Display	LED	Display		
CP3 Card missing (Test run possible)		CP3 Card missing			
—	Warning W1: CP3-Card Missing	red lights	Error E1: CP-Card Missing	No CP3 Card installed on the control board.	Install CP3 Card or start test run.
		CP3 Card is empty			
—	—	red lights	Error E2: CP-Card Empty	No data stored on the CP3 Card.	Install new CP3 Card.
		CP3 Card is defective			
—	—	red lights	Error E3: CP-Card Invalid	Invalid data stored on the CP3 Card.	Install new CP3 Card.
		CP3 Card is incompatible			
—	—	red lights	Error E4: CP-Card incompat	The installed CP3 Card is not compatible with the hardware of the unit or with the basic settings of the control electronics.	Install correct CP3 Card. Let your Condair service technician adjust the basic settings.
		Module B missing			
—	—	red lights	Error E5: Modul B Missing	Module B not correctly connected or defective.	Check module B and both connecting cables.
Extension unit missing		Main unit missing			
—	Warning W6: Extended Missing	red lights	Error E6: Main Missing	No communication between main unit and extension unit. Main or extension unit not switched on.	Check/connect bus cable. Switch on main unit and/or extension unit.
		Extension unit is in error status			
—	—	red lights	Error E7: Extended Error	The display of the main unit indicates that the extension unit is in error status. The type of error is shown on the display of the extension unit.	Take corresponding measures according to the indicated error type.
		Extension unit is not compatible			
—	—	red lights	Error E8: Extend.Incompat.	The CP3 Card of the main unit is not compatible with the one of the extension unit.	Install correct CP3 Cards into the units.
		Wrong hardware settings			
—	—	red lights	Error E9: Illegal Settings	False test run parameters.	Let your Condair service technician adjust the test run parameters (heating voltage, Cylinder-No.).

Warning		Error		Cause	Remedy
LED	Display	LED	Display		
		Hardware fault			
—	—	red lights	Error E10: Flash R/W Fault	Control board defective.	Replace control board.
—	—		Error E11: Clock R/W Fault	Backup battery on control board discharged.	Let have the backup battery be replaced.
On/Off timer active					
—	Warning W12: Timer Disable	—	—	The system is deactivated via the On/Off-Timer.	None. If necessary adjust On/Off timer settings.

8.1.2 Unit faults

Warning		Error		Cause	Remedy
LED	Display	LED	Display		
External safety chain is open					
red and green flash	Warning W20A: Safety loop open	—	—	Ventilation interlock open.	If applicable, check/turn on ventilation system.
				Air flow monitor triggered.	Check ventilator/filter of the ventilation system.
				Safety humidistat triggered.	Wait. If applicable, check safety humidistat
Max. filling level of steam cylinder reached		Max. filling level of steam cylinder reached but no heating current			
—	Warning W21A: Cyl.Max.Level	red lights	Error E21A: Cyl.Max.&NoCurr	Water conductivity too low (after initial operation).	Wait until the mineral content of the cylinder has increased
				Water conductivity too low for type of steam cylinder.	Select correct steam cylinder type.
				Phase failure heating voltage.	Check service switch in the mains supply line and switch on if applicable. Check mains fuse(s) and replace if applicable.
Permissible filling time exceeded (20 minutes)		Permissible filling time exceeded (more than 4 hours)			
—	Warning W22A: Max. Filltime	red lights	Error E22A: Max. Filltime	Water supply obstructed/shut-off valve closed/water pressure too low.	Inspect water supply (filter, water piping, etc.), check/open shut-off valve, check water pressure.
				Inlet valve blocked or defective.	Inspect strainer insert in the inlet valve, if applicable clean strainer insert or replace inlet valve.
				Excessive back pressure in the steam line (duct pressure too high, steam line too long or kinked), causing water loss via filling cup.	Check duct pressure, inspect steam installation. If applicable install pressure compensation kit (see options).
				Leakage in the water system.	Inspect water system and seal if necessary.

Warning		Error		Cause	Remedy
LED	Display	LED	Display		
No electrode current for more than 20 minutes		No electrode current for more than 4 hours			
—	Warning W23A: No Current	red lights	Error E23A: No Current	Phase failure heating voltage.	Inspect/turn on service switch of the mains supply line. Inspect the fuses of the mains supply, replace if necessary.
				Water supply obstructed/shut-off valve closed/water pressure too low.	Inspect water supply (filter, water piping, etc.), check/open shut-off valve, check water pressure.
				Inlet valve blocked or defective.	Inspect strainer insert of the inlet valve, if applicable clean strainer insert or replace inlet valve.
				Excessive back pressure in the steam line (duct pressure too high, steam line too long or kinked), causing water loss via filling cup.	Check duct pressure, inspect steam installation. If applicable install pressure compensation kit (see options).
				Leakage in the water system.	Inspect water system and seal if necessary.
Electrode current in relation to the steam demand too high		Electrode current in relation to the steam demand too high			
—	Warning W24A: Over Current	red lights	Error E24A: Over Current	Humidity demand has decreased too fast.	Automatic adaptation of the operating point.
				Drain pump defective.	Inspect drain pump, replace if necessary.
				Drain in steam cylinder blocked.	Clean/replace steam cylinder.
				Water conductivity too high for this type of steam cylinder.	Select correct steam cylinder type.
Max. admissible electrode current exceeded		Max. admissible electrode current exceeded			
—	Warning W25A: Excess Current	red lights	Error E25A: Excess Current	Drain pump defective.	Inspect drain pump, replace if necessary.
				Drain in steam cylinder blocked.	Clean/replace steam cylinder.
				Water conductivity too high for this type of steam cylinder.	Select correct steam cylinder type.
		Main contactor jammed			
—	—	red lights	Error E26A: Req.Off Current	Main contactor jammed in activated position.	Inspect main contactor, replace if necessary.
Foam detection		Foam detection (4 automatic drainings within 24 hours)			
—	Warning W27A: Foam	red lights	Error E27A: Foam	Foaming in steam cylinder.	Drain steam cylinder via drain key (several times, if necessary). Check quality of the supply water.
Steam cylinder needs service		Service interval for steam cylinder exceeded			
yellow lights	Warning W28A: Cyl. Maintenance	red and yellow flash	Error E28A: Cyl. Maintenance	Mineral deposits and/or electrodes spent.	Steam cylinder Type A: replace Steam cylinder Type D: clean Important: After replacement or cleaning of the steam cylinder, reset the maintenance counter (see chapter 7.6).
Steam cylinder needs service		Max. operating hours of the steam cylinder reached			
yellow lights	Warning W29A: Cyl. Maintenance	red and yellow flash	Error E29A: Cyl. Maintenance	Maximum operating hours of the steam cylinder reached.	Steam cylinder Type A: replace Steam cylinder Type D: clean Important: After replacement or cleaning of the steam cylinder, reset the maintenance counter (see chapter 7.6).

Warning		Error		Cause	Remedy
LED	Display	LED	Display		
Humidity sensor signal (signal Y) missing		Humidity sensor signal (signal Y) missing for more than 1 minute			
—	Warning W32A: Ctrl.Sens.Broken	red lights	Error E32A: Ctrl.Sens.Broken	No sensor signal present at signal input (Signal Y).	Check humidity sensor (signal Y) , replace if necessary. Inspect wiring.
Signal of humidity limitation sensor (signal Z) missing		Signal of humidity limitation sensor (signal Z) missing for more than 1 minute			
—	Warning W33A: Lim.-Sens.def.	red lights	Error E33A: Lim.Sens.Broken	No sensor signal present at signal input (signal Y).	Check humidity sensor (signal Y) , replace if necessary. Inspect wiring.
Module A (B) locked via Modbus					
—	Warning W34A: Modbus disable	—		Module A (B) locked because the corresponding Modbus register is deactivated.	Activate the corresponding Modbus register.
		Modbus Timeout (5 s)			
—	—	red lights	Error E35A: Modbus Timeout	No actual demand or humidity signal received via Modbus.	Send actual demand or humidity signal.
Standby draining of steam cylinder active					
—	Warning W36A: Standby Drain	—	—	Automatic standby draining of steam cylinder active.	No measures must be taken.
Forced draining of steam cylinder active					
—	Warning E37A: Forced Drain	—	—	Forced draining of steam cylinder active.	No measures must be taken.

8.2 Notes on fault elimination

 WARNING!	<p>For the elimination of faults set the steam humidifier out of operation as described in chapter 6.3, separate the unit from the mains and secure it against inadvertent power-up.</p>
--	---

The elimination of faults must be carried out by qualified and well trained professionals only. Malfunctions relating to the electrical installation (e.g. replacement of fuses) must be repaired by authorized personnel or by your Condair representative's service technician only.

Repair work and the replacement of faulty components must be carried out by your Condair representative's service technician only!

8.3 Resetting the error indication (red LED lights)

To reset the error indication:

Disconnect the steam air humidifier from the mains. Wait approx. 5 seconds, then reconnect the unit to the mains.

Note: If the fault has not been eliminated, the error indication reappears after a short while.

9 Taking out of service/Disposal

9.1 Taking out of service

If the Condair CP3 must be replaced or if the humidification system is not needed any more, proceed as follows:

1. Take the unit out of operation as described in chapter 6.3.
2. Have the unit (and all other system components, if necessary) unmounted by a qualified service technician.

9.2 Disposal/Recycling

Dismantled components must be disposed of and/or recycled according to the local regulations. In case of doubt please contact your Condair supplier.

10 Product specifications

10.1 Technical data

Heating voltage 230V/1~/50..60Hz													
Unit model:	Basic		Pro										
	5..8												
Steam capacity in kg/h:	5..8												
Max. power consumption in kW	3.8..6.0												
Heating voltage 230V/3~/50..60Hz													
Unit model:	Basic	Pro	Basic	Pro	Basic	Pro	Basic	Pro	Basic	Pro	Pro	Pro	
	5..8		9..15		16..21		22..30		44/50		75/90	100/120	
Steam capacity in kg/h:	5..8		9..15		16..21		22..30		44/50		75/90	100/120	
Max. power consumption in kW	3.8..6.0		6.8..11.3		12.0..15.8		16.5..22.5		33.0/37.6		56.5/76.5	75.0/90.0	
Heating voltage 400V/3~/50..60Hz													
Unit model:	Basic	Pro	Basic	Pro	Basic	Pro	Basic	Pro	Basic	Pro	Pro	Pro	
	5..8		9..15		16..25		26..45		52/60/70/80/90		105/120/135	152/160/180	
Steam capacity in kg/h:	5..8		9..15		16..25		26..45		52/60/70/80/90		105/120/135	152/160/180	
Max. power consumption in kW	3.8..6.0		6.8..11.3		12.0..18.8		19.5..33.8		39.0..67.5		78.8..101.3	114.0..135.0	
Control voltage	1 x 230V / 50-60 Hz						2 x 230V / 50-60 Hz						
Operating conditions													
Admissible water pressure	1...10 bar												
Water quality	Untreated drinking water with a conductivity of 125...1250 uS/cm												
Admissible water temperature	1...40 °C												
Admissible ambient temperature	1...40 °C												
Admissible ambient humidity	max. 75% rh												
Admissible duct air pressure	-0.8 kPa...1.5 kPa; overpressure kit (option) up to 10.0 kPa												
Type of protection	IP 20												
Conformity	CE, VDE, GOST												
Dimensions/Weights													
Housing (WxHxD) in mm	456x620x280	1	1	1	1	1	1	1	1	2	2	3	4
	559x667x350												
Net weight in kg		21	21	21	21	28	28	28	28	2x 28	2x 28	3x 28	4x 28
Operating weight in kg		26	26	32	32	32	32	65	65	2X 65	2X 65	3X 65	4x 65
Equipment/options													
Steam cylinder type	A3.../D3...	1	1										
(Type A.. standard equipment)	A4.../D4...			1	1								
	A6.../D6...					1	1	1	1	2	2	3	4
Steam hose connector	SC22	1	S										
	SC60			1	S								
	SC80					1	S	1	S	2	S	S	S
Steam hose connector with condensate trap	SCCT22	1											
	SCCT60			1									
	SCCT80					1		1		2			
Condensate trap	CT22		1										
	CT60				1								
	CT80					1		1		2		3	4
Cable gland	PG	1	S	1	S	1	S	1	S	1	S	S	S
Overpressure set	OPS	1	1	1	1	1	1	1	1	2	2	3	4
Remote operating and fault indication	RFI	1	S	1	S	1	S	1	S	1	S	S	S
Terminals heating voltage	M-THV	1	S	1	S								
	L-THV					1	S	1	S	2	S	S	S
Mounting profile	MP	1	1	1	1	1	1	1	1	1	1	3	4
Internal control voltage with terminals	M-CVI	1	1	1	1								
	L-CVI					1	1	1	1	1	1	2	2
Transformer 400V/230V	M-Trafo	1	1	1	1								
	L-Trafo					1	1	1	1	1	1	2	2
Housing front cover, stainless steel	M-INOX	1	1	1	1								
	L-INOX					1	1	1	1	2	2	3	4
Accessories													
Steam distribution pipe	41-...	1	1										
	61-...			1	1								
	81-...					1	1	1	1	2	2	3	4
Steam distribution system OptiSorp	System 1	1	1	1	1	1	1	1	1				
	System 2									1	1		
	System 3											1	
	System 4												1
Fan unit	FAN B15	1		1									
	FAN B45				1		1		2				
	FAN P15		1		1								
	FAN P45					1		1		2		3	4
Steam hose / meter	DS22	1	1										
	DS60			1	1								
	DS80					1	1	1	1	2	2	3	4
Condensate hose / meter	KS10	1	1	1	1	1	1	1	1	2	2	3	4

10.2 Unit dimensions

Condair CP3 5...15 (dimensions in mm)

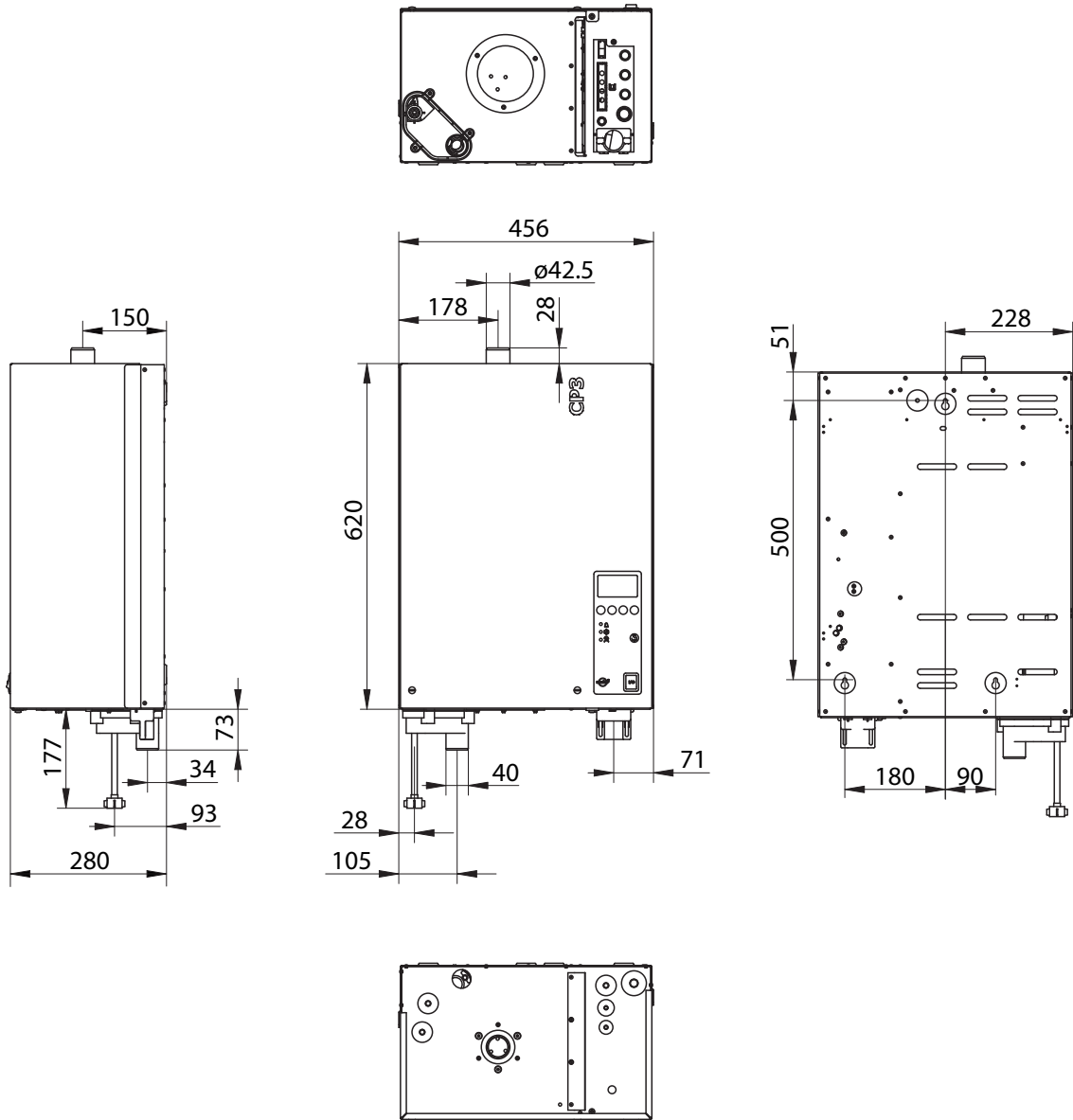

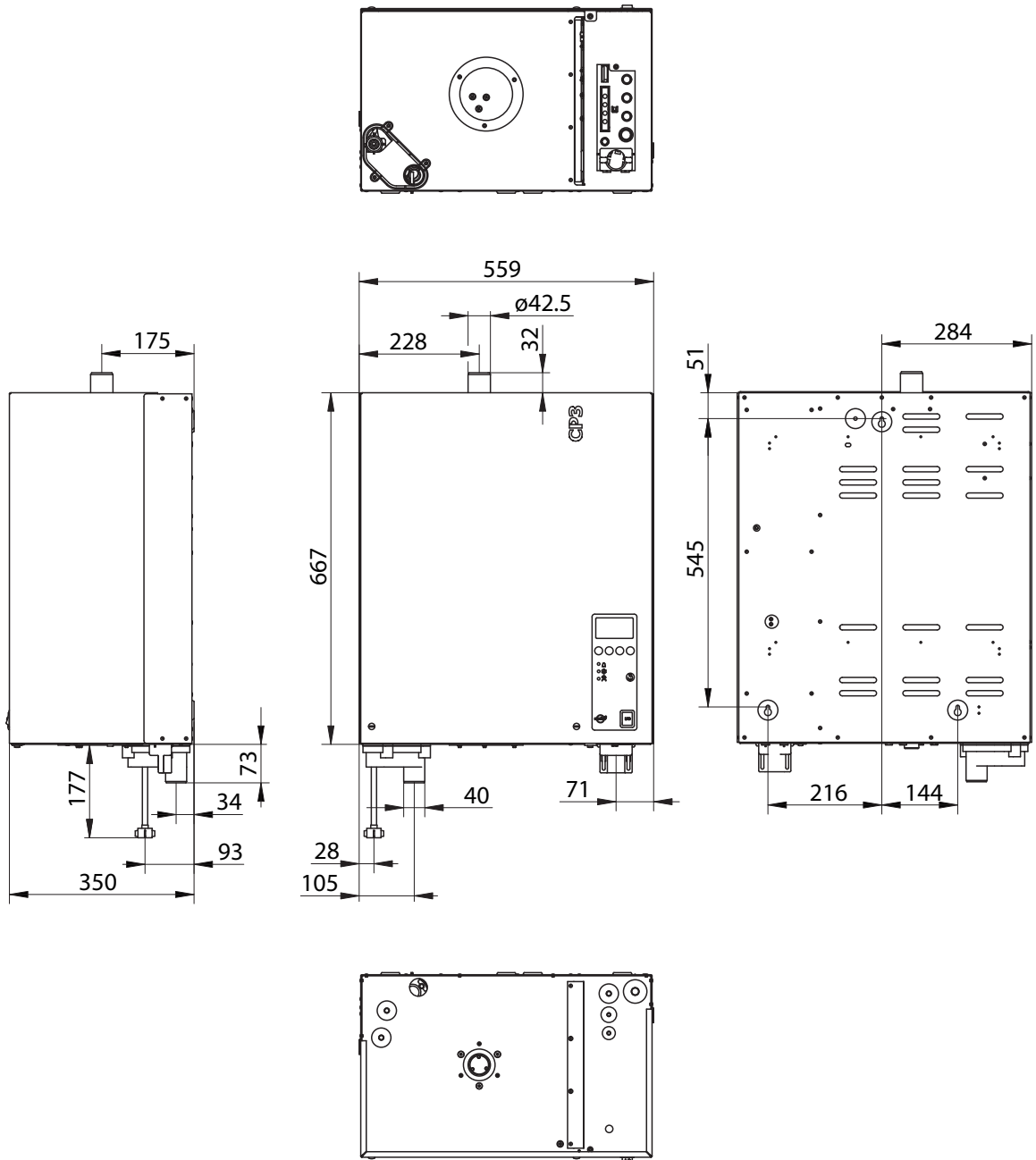
Condair CP3 16...45 (Dimensions in mm)



CONSULTING, SALES AND SERVICE:

Solutions for Indoor Climate



Reg.No. 40002-2

Manufacturer:

Walter Meier (Climate International) Ltd.

Talstr. 35-37, P.O. Box, CH-8808 Pfäffikon (Switzerland)

Phone +41 55 416 61 11, Fax +41 55 416 62 62

www.waltermeier.com, international.climate@waltermeier.com

**walter
meier**