

Condair Esco

Steam humidification system

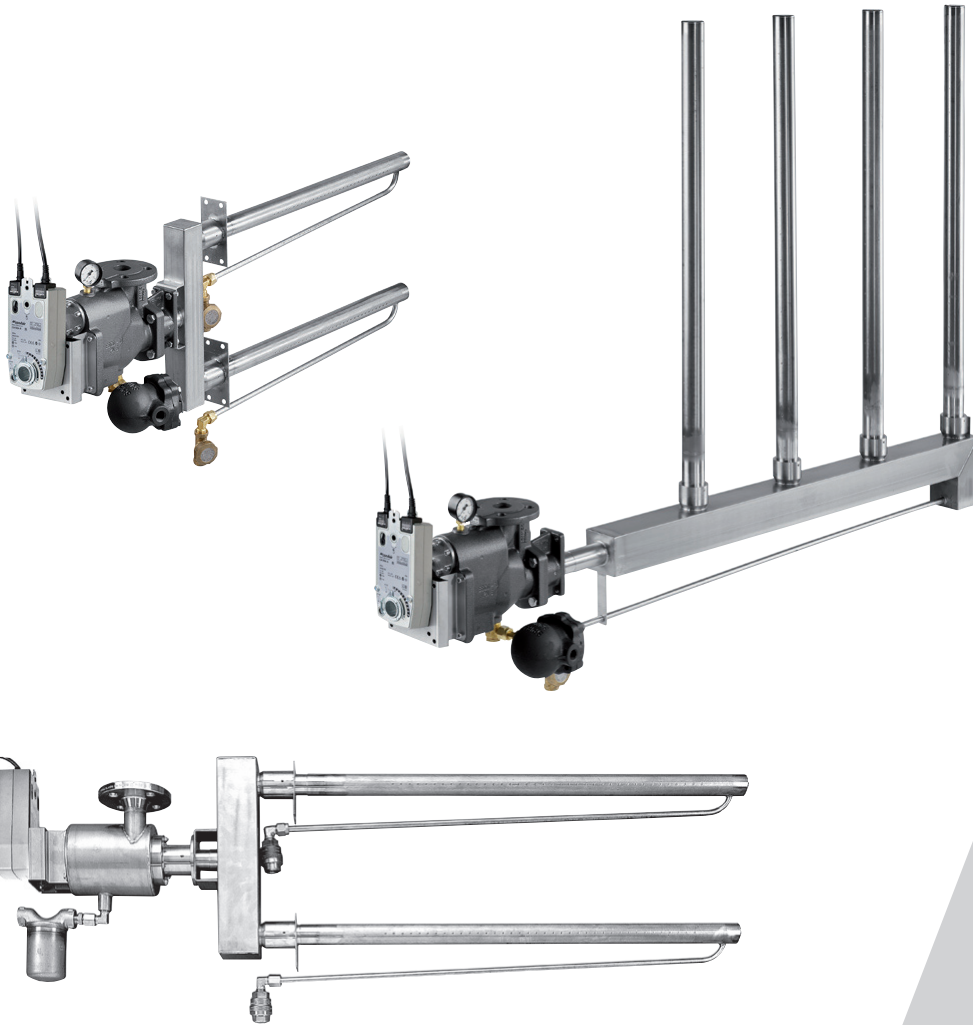

INSTALLATION AND OPERATING INSTRUCTIONS

Possible applications for the Condair Esco live steam humidification system

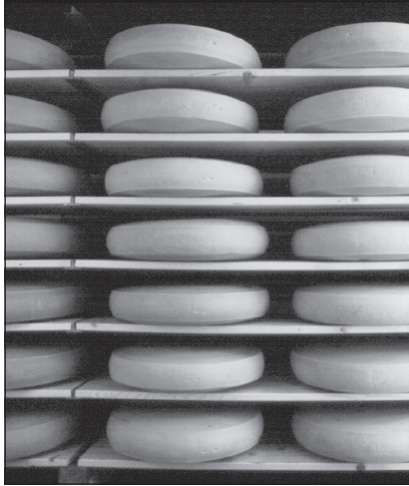

In the proximity of machinery and production processes, optimal air humidity is essential. Of course for hospitals, as well as clinics, laboratories, and the chemical and pharmaceutical industries, air humidity and hygiene is an absolute necessity. In storage rooms, where organic matter like fish, vegetables or tobacco is kept for longer periods of time, optimal air humidity will prevent undesired drying and preserve the freshness. It improves the health and well-being of people, animals and plants, especially during the heating season. Condair Esco's steam air humidification system satisfies these requirements to a high degree.

Why humidify with steam?



To humidify the air with water vapour is the most direct, simplest, and safest method. Humidity contained in air is called water vapour. To humidify the air means increasing its water vapour content. The Condair Esco steam humidification system raises the lacking humidity to the proper, optimal value without any undesired side-effects.

Using steam to humidify the air...



- is indisputably the most hygienic method (sterile)
- causes no disturbing odours
- hardly affects the temperature of the air (isothermal)
- prevents waterborne mineral deposits from accumulating in air ducts and rooms
- allows optimal control of the air humidity
- requires minimal maintenance

Contents

1	Important notes	6
1.1	Correct use for intended purpose	6
1.2	Safety instructions	7
1.3	Notes on the installation and operating instructions	8
1.4	Warranty/liability	8
2	The Humidifier	9
2.1	Steam humidification system Condair Esco	9
2.2	System Condair Esco 5	10
2.3	System Condair Esco 10, 20 and 30	13
2.4	Function	14
2.5	Connection unit	15
3	Humidifier selection	17
3.1	The essentials in brief	17
3.2	Connection unit and ceramic rotary-disk control valve	19
3.3	Rotary control valve actuator	20
3.4	Steam distribution	24
3.6	Manometer	28
3.7	Condair Esco stainless steel	29
4	Hints for the consulting engineer and the HVAC technician	36
4.1	The use of steam in air humidification	36
4.2	Installation instructions	37
4.3	Using the humidification distance diagrams	37
4.4	Installation in systems or ducts	43
4.5	Dimension diagrams	45
4.6	Dimensions diagrams for installation	47
4.7	Connection diagrams for actuators	50
5	Hints for the heating engineer	52
5.1	Connecting the steam supply pipe	52
5.2	Installing the steam pipes	52
5.3	Schematic diagram	56
5.4	Connections to be prepared by customer	57
6	Initial start-up	58
7	Maintenance	59
8	Trouble-shooting guide	60
9	Vaporisation / condensation	61
9.1	Terminology and definitions	61
10	Work sheet DR73 / DL40	63

1 Important notes

Please read this chapter carefully. It contains important information, which must be observed for safe, correct, and economic operation of the steam humidification system Condair Esco.

1.1 Correct use for intended purpose



Steam humidification systems Condair Esco are intended **exclusively** for indirect humidification via steam distribution pipe in a ventilation duct. For applications in process technology systems, please consult the supplier. Any other type of application is considered as not conforming with the intended purpose. **The supplier cannot be made liable for any damage resulting from improper use. The user bears full responsibility.**

Correct use for intended purpose further includes:

- Observation of the instructions, regulations and notes contained in the present installation and operating instructions for the steam humidification system Condair Esco.
- These **installation and operating instructions** contain all information required for planning a humidification project which utilises the steam humidification system **Condair Esco**. In addition, it contains all information necessary to install such a system.
- The installation and operating instructions are intended for use by engineers, planning personnel and system constructors entrusted with the design of humidification systems. It is assumed, that these persons have a good understanding of the ventilation and humidification technology.
- The steam humidification system Condair Esco incorporates the latest technical advances and meets all recognised safety regulations (manufacturer's statement). Ignorance of appliance-specific qualities or improper use, however, can result in danger to the user or third parties and/or impairment of the system and other material values.
- The **notes** in the installation and operating instructions concerning the planning /layout of a humidification system, and the installation details for the steam humidification system Condair Esco **must be observed and followed** without fail.



The following points must be observed in addition to these installation and operating instructions:

- All local safety regulations concerning the use of pressurised steam systems.
- All local safety regulations concerning the use of mains-supplied electrical equipment.
- All instructions and warnings in the publications for the products used in conjunction with the steam humidification system Condair Esco.
- All safety regulations concerning the system in which the steam humidification system Condair Esco is fitted.
- All instructions and warnings provided on the steam humidification system Condair Esco.
- All local sanitary regulations.

The well organised world-wide Condair distributor network provides service at all times by qualified technicians. Please contact your supplier if you have any queries concerning the steam humidification system Condair Esco or humidification technology in general.

1.2 Safety instructions

- The steam humidification system Condair Esco must only be installed, operated and serviced by persons familiar with this product and sufficiently qualified for the task. The customer must ensure that the installation and operating instructions are supplemented by internal instructions with respect to supervisory and notification liability, work organisation, personnel qualification, etc.
- Persons unfamiliar with the operating instructions must neither operate nor service the steam humidification system Condair Esco. The user of this steam humidification system is responsible for preventing any unauthorised persons from operating this humidifier.



- Without proper qualifications, no operations may be carried out for which the consequences are not known. In case of doubt, the supervisor or the supplier must be contacted.
- **Original Condair accessories and options** from your supplier must be used **exclusively** for installation of the steam humidification system Condair Esco.
- **Without the written consent** of the supplier, no attachments or modifications must be made to steam humidification systems Condair Esco, accessories, and options.
- Original Condair spare parts from your supplier must be used exclusively for service and maintenance of the steam humidification system Condair Esco.
- **Do not remove the flanges from the steam connection units.**

1.3 Notes on the installation and operating instructions

Limitation

Comments in the present installation and operating instructions “Steam Humidification System Condair Esco” are limited to details:

- on the proper **planning** of systems
- on the proper **installation**
- on the proper **commissioning** procedure
- on the proper **operation** and **maintenance**
- on **service** and **trouble-shooting**

Safekeeping

Keep these installation and operating instructions in a safe place where it is always available. If applicable, it must be passed on to subsequent users. If this documentation is misplaced, please contact your supplier.

Language versions

Contact your supplier if you require another language version of your installation and operating instructions.

1.4 Warranty/liability

Warranty entitlements expire, and no liability is assumed for damages caused by:

- improper installation or application contrary to the intended purpose
- installation of modifications which were not approved by Condair
- improper maintenance by unqualified personnel
- using spare parts and accessories other than original Condair ones

2 The Humidifier

2.1 Steam humidification system Condair Esco

Wherever **existing steam is employed** for humidification, the steam humidification systems Condair Esco, DR73 and DL40 **prove to be outstanding**. The **precisely controlled steam mass flow is evenly distributed into the air current, void of any condensate spray**. Steam humidification systems Condair Esco, type DR73 and DL40 operate very reliably. They are compact, easily installed, and thanks to **computerised layout**, permit a **system-optimised humidification distance**. The absolutely steam-tight **rotary-disk control valve prevents temperature energy losses** in the closed position.

- **Safe operation**

Strainers, water separators, as well as primary and secondary condensate drains ensure **clean, condensate-free steam**. The nozzles, tapping the steam at the **centre of the distribution pipe**, render the jacket heating unnecessary, because accumulating condensate is drained via secondary steam trap.

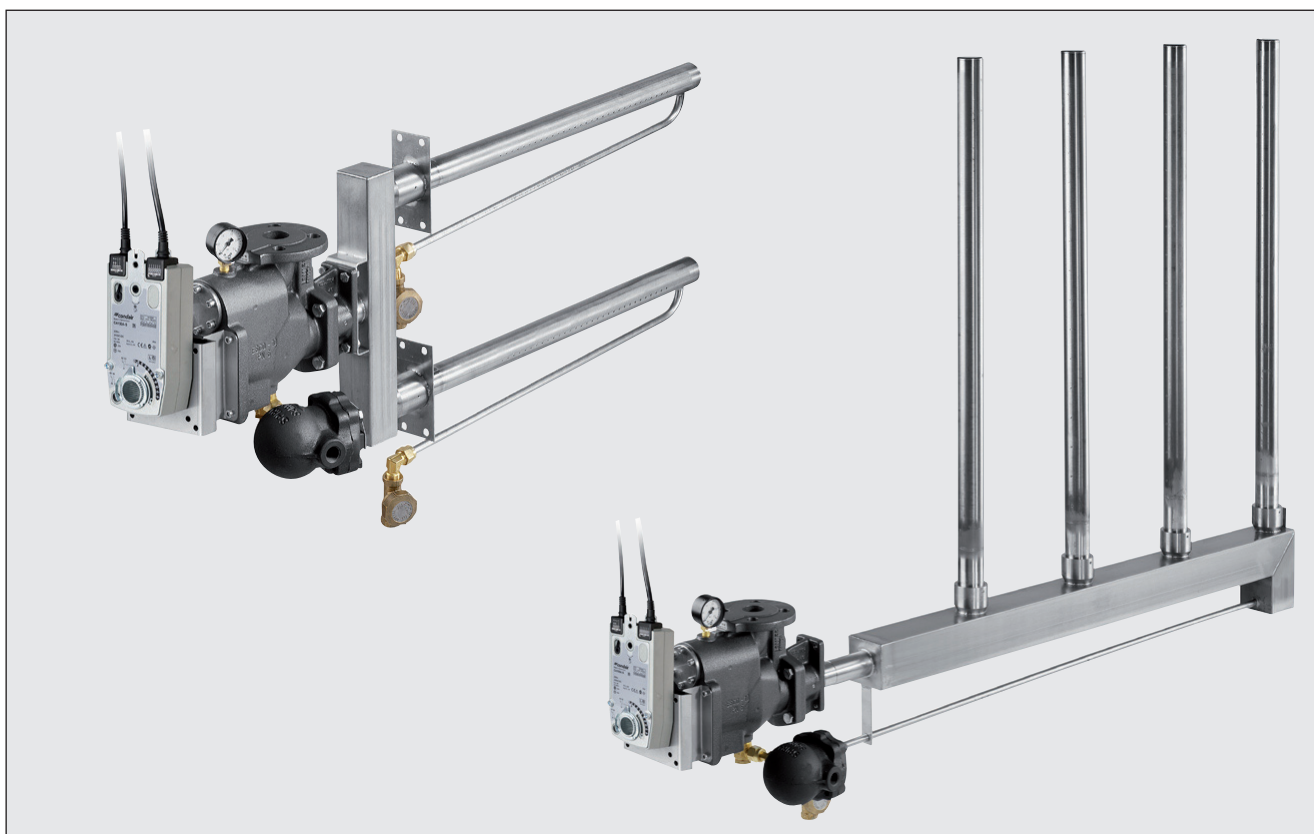

- **Compact**

Strainer, water separator, steam trap, rotary-disk control valve and rotary actuator form a **compact unit**, requiring little space.

- **Easy to install**

Combining all **important parts** into one **compact unit**, averts the need for expensive additional installations and prevents sealing problems during installation.

2.2 System Condair Esco 5

Small, compact valve-unit with integrated ceramic rotary-disk valve and mounted steam connection flange. 1/2"-female thread for the steam supply pipe. Designed for the connection to DL40 standard single-steam distributors 5/023 - 5/178.

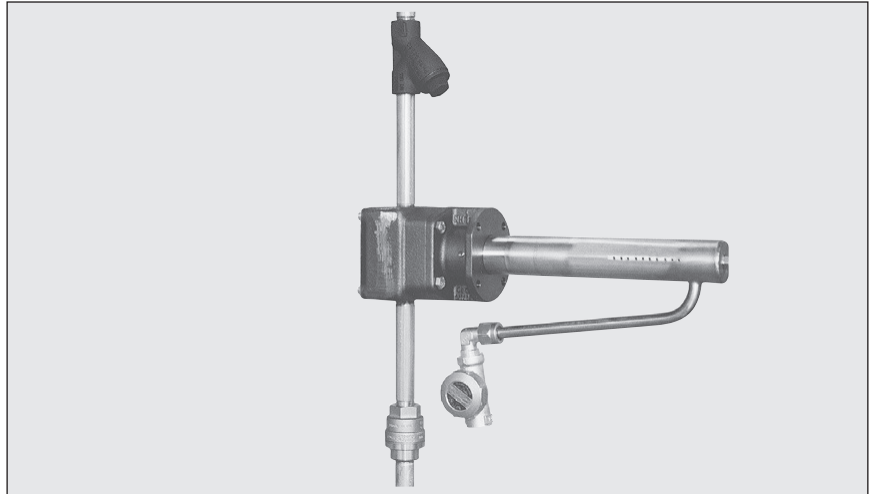

Technical specifications:

Max. steam capacity	127 kg/hr (with $p_1 = 4$ bar)
Valve admission pressure p_1	0.2...4.0 bar
Valve-sizes	5/1...5/7

Accessory:

Primary, thermostatic steam trap including 1/2"-connection fitting; execution complete stainless steel. The thermostatic steam trap immediately adjusts to changing operation terms and it deaerates automatically. Condensate is removed with a supercooling of 4 K.

Actuators:

The following actuators can be mounted:

- 1) electrical rotary disk actuators CA75, CA150A, CA150A-S
- 2) pneumatic actuator type P10

Options:

- Strainer, delivered loose (installation recommended)
- Mounting set for insulated ducts
- Adaptors for the mounting of other electrical rotary actuators
- Positioner XSP31 with mounting kit to pneumatic actuator P10

Steam distribution pipes DL40-Esco 5		
Type	Duct width mm	m_D kg/hr
5/023	275 - 424	16
5/038	425 - 524	27
5/048	525 - 624	32
5/058	625 - 724	41
5/068	725 - 924	50
5/088	925 - 1224	62
5/118	1225 - 1524	94
5/148	1525 - 1824	118
5/178	1825 - 2124	127

Valve size diagram Condair Esco 5

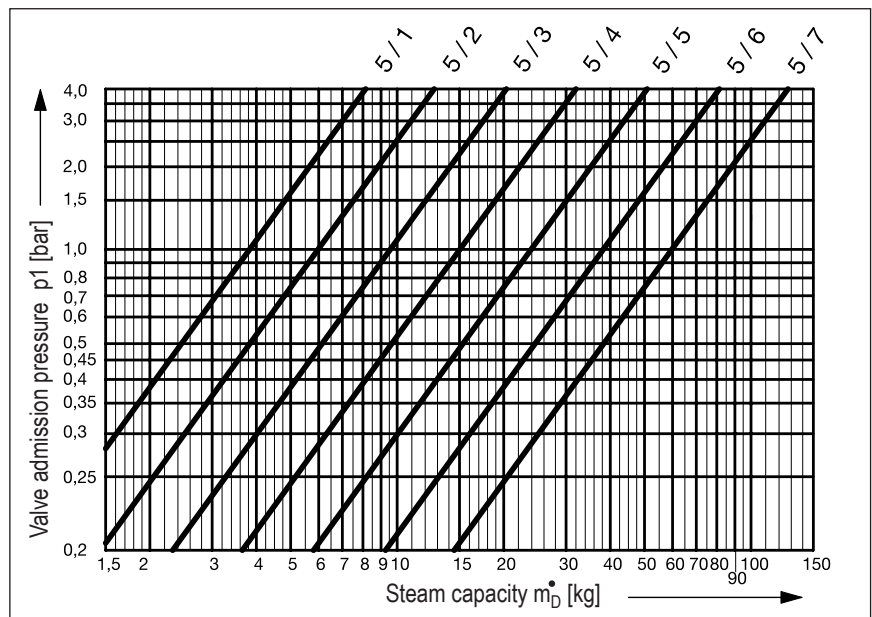
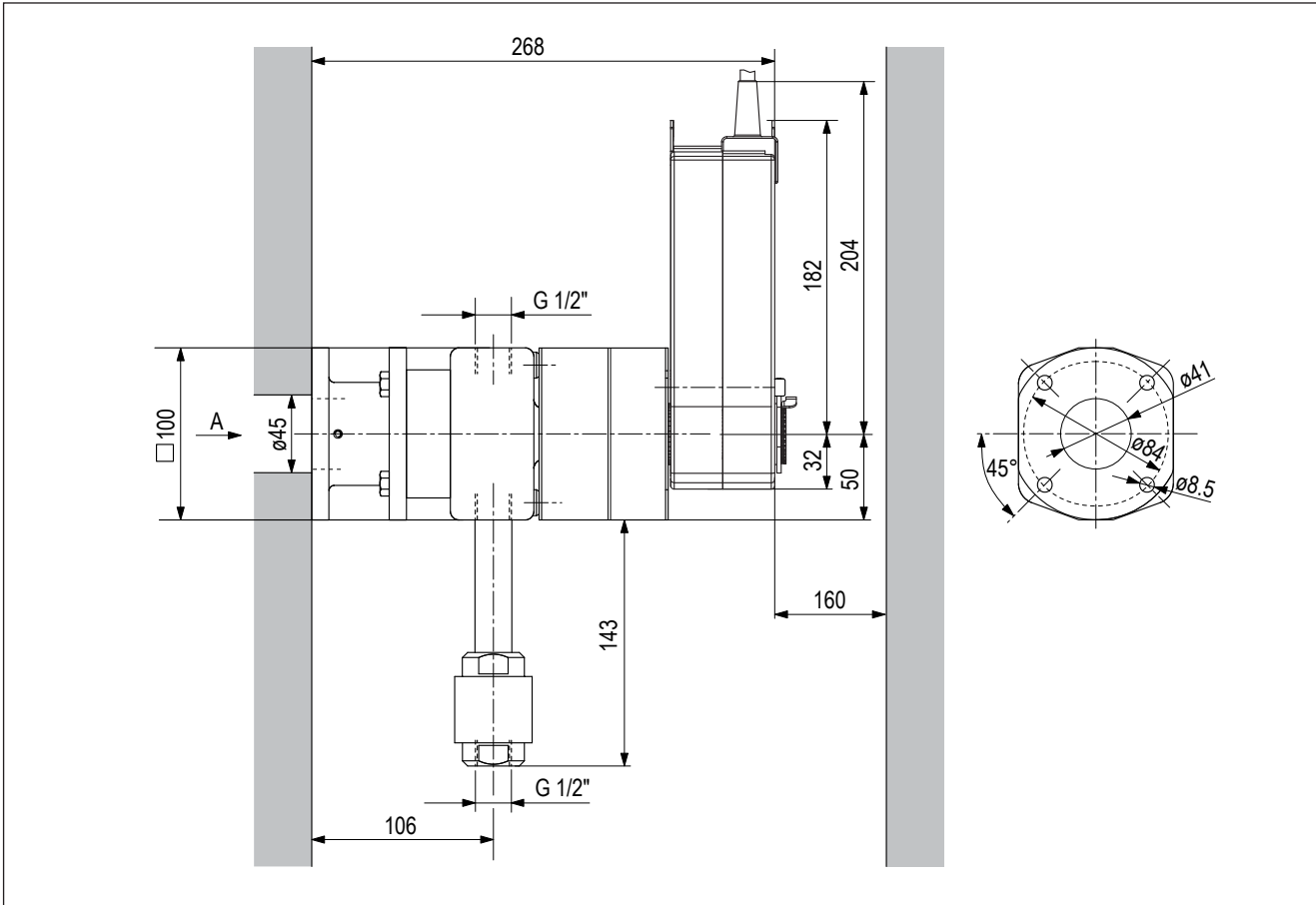

Diagram for determining the dimension of the **Esco 5** steam connection unit with appropriate valve size.

2.2.1 Material specifications Condair Esco 5

Version	Standard
Valve-body, flange	GGG40
Valve-disks	SIC
Drive shaft	1.4305 (AISI 304)
Live spindle	CuZn
Compression spring	1.4401 (AISI 316L)
Flat packing	PTFE
O-ring seals	EPDM/PTFE
Fittings	galvanised steel
Tooth-and locking plates	1.4110
Double nipple for primary steam trap	1.4404 (AISI 316L)
Primary steam trap, thermal	1.4301
Strainer SF12:	
Housing	GGG40
Screen	1.4301 (AISI 304)

2.2.2 Dimension diagram Condair Esco 5 steam connection unit, rotary disc actuator CA150A / CA150A-S



2.2.3 Dimension diagram Condair Esco 5 steam connection unit, rotary disc actuator CA75

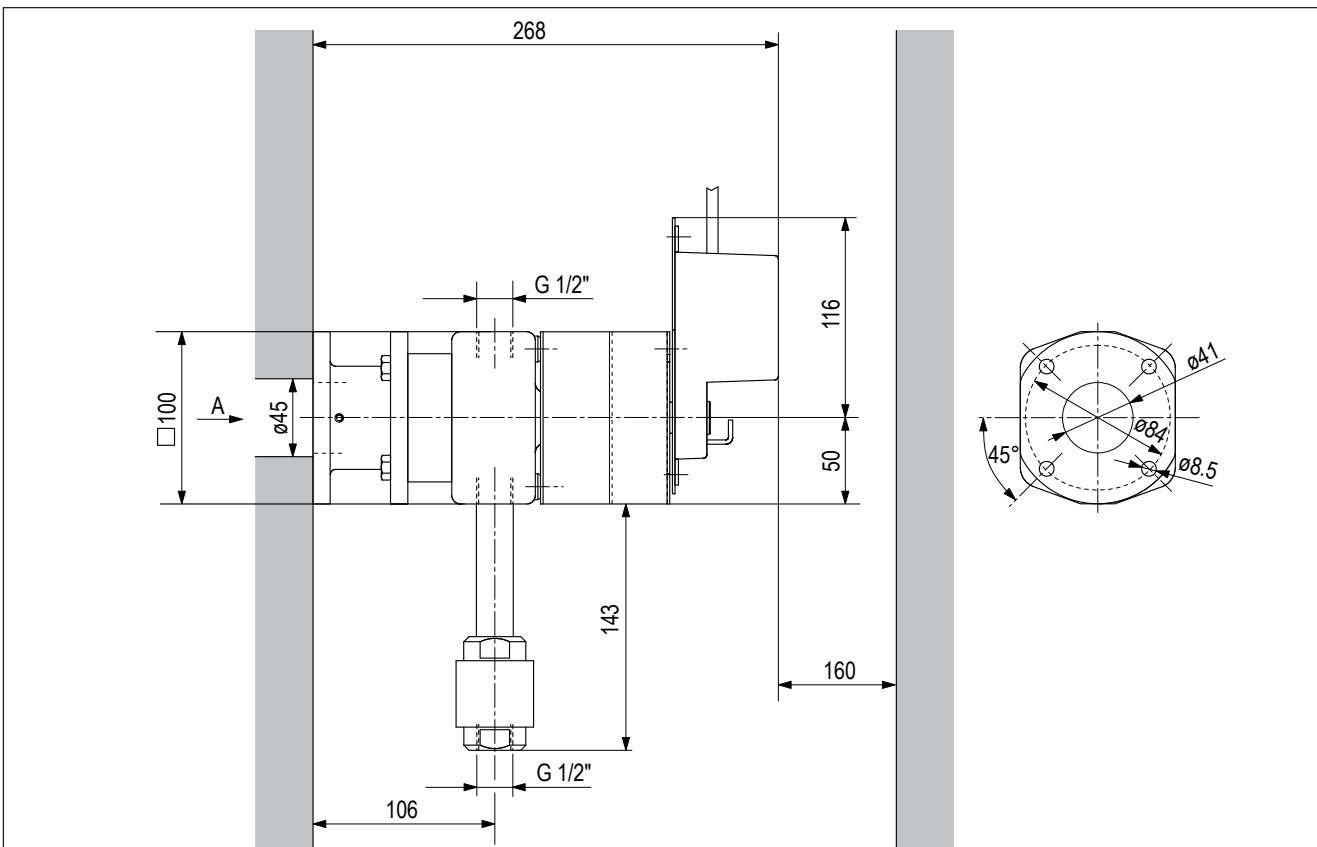

2.3 System Condair Esco 10, 20 and 30

Complete steam connection unit with rotary disk actuator and water separator for humidifiers type **DR73** and **DL40**.

DR73

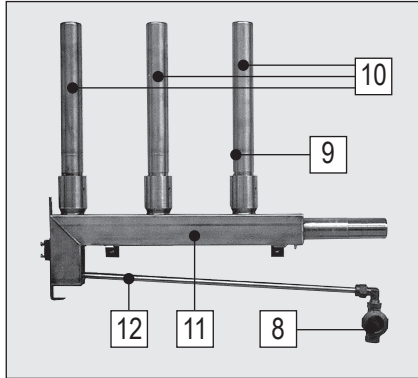

DL40

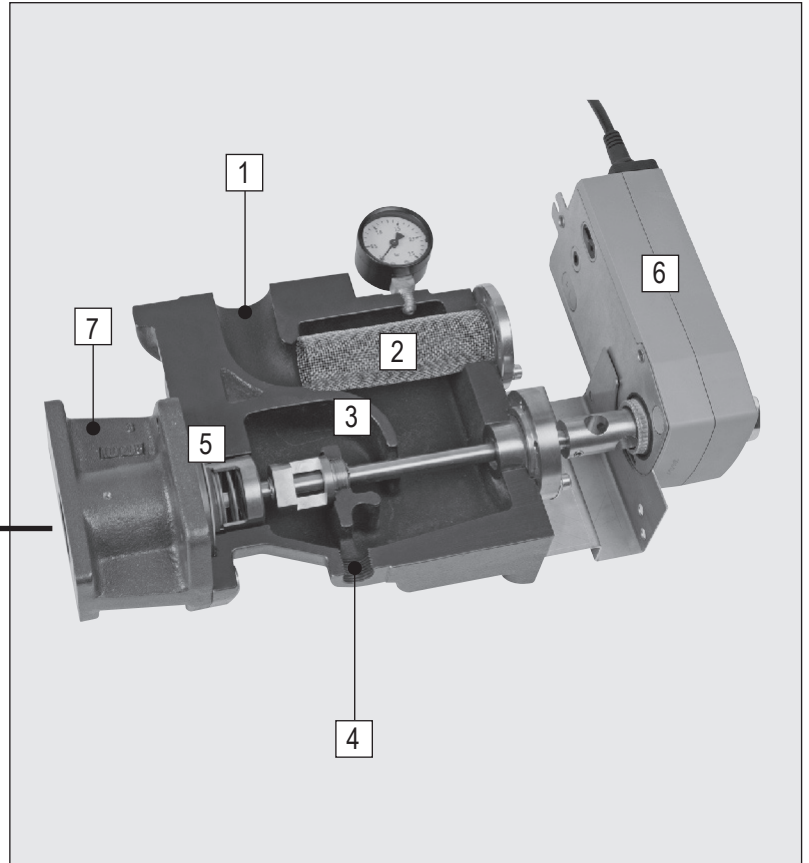
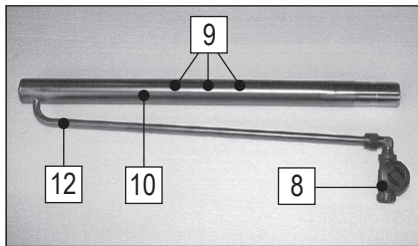

- | | | | |
|---|-------------------------------------|----|----------------------------|
| 1 | Steam connection | 7 | Connecting flange |
| 2 | Strainer | 8 | Secondary condensate drain |
| 3 | Water separator | 9 | Steam nozzles |
| 4 | Primary condensate drain connection | 10 | Steam distribution pipe |
| 5 | Ceramic rotary-disk control valve | 11 | Main distribution pipe |
| 6 | Rotary actuator | 12 | Condensate return line |

Type DR73 and DL40, of the steam humidification system Condair Esco, **blow precisely controlled**, dried steam, uniformly into the air current, void of any condensate spray.

Steam distribution takes place via steam distribution pipes with integrated nozzles. The nozzles, tapping the steam at the centre of the distribution pipe, render the jacket heating unnecessary, because accumulating condensate is drained via secondary steam trap. Operational reliability and compact, easy-to-install design characterise this steam humidification system.

2.4 Function

On the inlet side, the steam humidification systems Condair Esco DR73 and DL40 are connected to the live steam supply. The **steam on hand**, when the ceramic rotary-disk control valve is closed, **is continuously drained** by means of the primary condensate drain (spheric float). Thus, the humidifier is **operable any time**. The steam distributor, however, remains cold and does not heat the air current; **no energy is wasted**.

With the ceramic rotary-disk control valve open, the steam passes through the strainer into the water separator. As a result of the multiple steam deflection in the water separator, the **condensate, carried along, is reliably eliminated** and drained via primary condensate drain.

In the **DR73 type**, the **dried steam** exits the water separator through the ceramic rotary-disk control valve to flow via main distribution pipe into the **vertically arranged secondary pipes**. The hot, dry steam is tapped at the centre of the steam distribution pipes and discharged under pressure **on both sides**, by means of special nozzles, **at an angle to the air current**. Condensate, accumulating in the vertical pipes, slides along the inside of the pipe down into the horizontally attached main distribution pipe (= collector). This spaciouly designed pipe is **drained** by way of an externally mounted **thermal** secondary condensate drain.

In the **DL40 type**, the **steam is directly** routed into the **steam distribution pipe**, tapped at the centre of it and discharged under pressure, by means of special nozzles, **into or against the air current**. Condensate, accumulating along the inside of the pipe, is drained via condensate return line by way of an externally mounted thermal secondary condensate drain.

Any condensate accumulating during system start-up is immediately drained by the primary steam trap. The pre-dried steam is led via control valve into the distribution system, where it is taken from the dry center of the pipe and introduced uniformly into the volume flow by means of the differential pressure. Thanks to this dependable system, there is no need for a start-up protection and jacket heating.

Condensate-related backpressure is an impossibility in both lines of products even in a pressureless state, because the steam distributor pipe is drained via condensate return line with inherent down gradient.

2.5 Connection unit

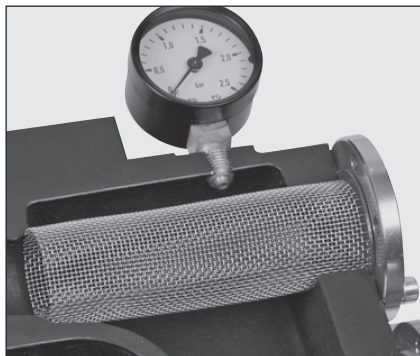

- **Steam connection**

Connection to the steam supply is made from the top by means of a standard flange.

- **Strainer**

The **strainer** is located **inside** the **connection unit** at an angle of 90 degrees to the steam inlet. **Its unique design** results in a uniform **flow of steam**, at a significantly reduced velocity, through the **entire screen area** into the water separator. If required, the **threaded connection facilitates cleaning** the screen.

- **Water separator**

The **water separator removes the condensate droplets** carried along by the **steam** entering through the strainer. The droplets slide down the inner wall of the water separator into the primary condensate drain. The **dried steam flows to the ceramic rotary-disk control valve**.

- **Steam trap**

The steam humidification systems Condair Esco DR73 and DL40 both utilise a **primary and a secondary condensate drain**. The **primary condensate drain consists of a spheric float** that adapts to pressure and capacity fluctuations and continuously drains the condensate from the steam connection unit (alternatively a drain with a bell-shaped float may be used instead).

The **secondary condensate drain** empties the condensate accumulating in the steam distribution pipes. This **thermal steam trap is maintenance-free**.

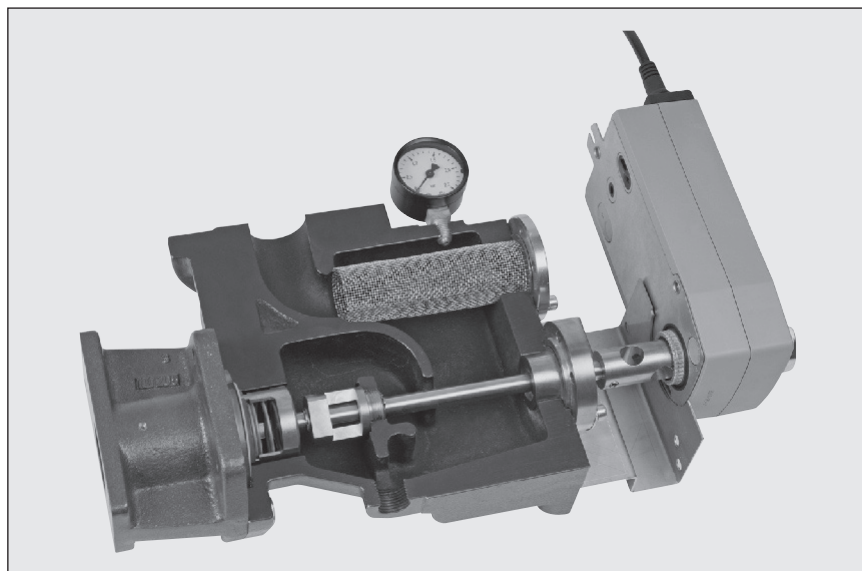

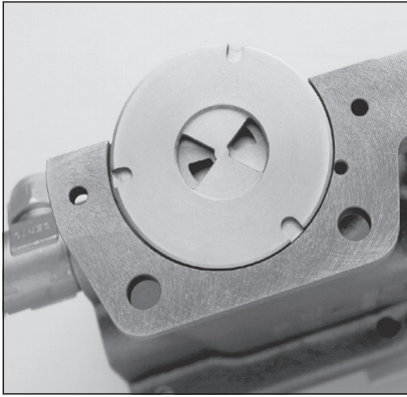

- **Ceramic rotary-disk control valve**

The humidifier control valve consists of two SiC (silicon carbide) ceramic disks, pressing against each other. One of them is fixed, while the other one is rotating. It is distinguished by the following features:

- **Compact design:** The control valve is integrated into the connection unit.
- **Tightness:** With the ceramic rotary-disk control valve closed, no steam can pass into the humidification section. Thus, the tightly sealing valve prevents undesired formation of condensate and damage, caused by off-periods (corrosion etc.).
- Beyond the opening point of the valve the **characteristic curve of the control valve** is linear for the entire regulating range.
- **Rotary control valve actuators:** One standardised rotary control valve actuator with emergency function for all valve bodies. A second rotary actuator (without emergency function) is available for low-capacity humidifiers.

Specifications:

Primary steam pressure range PN6 connection unit: 0.2....4.0 bar
 (Pressure values are generally expressed in bar overpressure)

Max. primary steam temperature: 152 °C

Leak rate of SiC ceramic rotary-disk control valve: 0.0001%

Standard
GGG 40
SiC
1.4301 (AISI 304)
GG20 (T90-20/T90-30) 1.4301 (T90-10)
CuAl10Ni5Fe4
1.4305
CuZn (T90-10/T90-20) 1.4305 (T90-30)
1.4401 (AISI 316L)
PTFE
CuZn
CuZn
GGG 40
EPDM / PTFE-FEP
CuZn
GGG 40
1.4301
1.4305

- Version
- Valve body/water separator/flange
- Ceramic rotary-disk control valve
- Strainer
- Filter cover
- Stuffing box
- Valve stem
- Valve catch
- Compression spring
- Flat-packing
- Bearing
- Threaded joint for primary condensate drain
- Primary condensate drain (spheric float drain)
- O-ring seals
- Manometer
- Coupling piece to actuator
- Complete steam distribution system DR73 and DL40
- Steam nozzles

3 Humidifier selection

3.1 The essentials in brief

When tendering or ordering, it should be noted that the steam humidification system Condair Esco, type DR73 and DL40 consists of the following components (*=optional):

1. Connection unit
2. Ceramic rotary-disk control valve
3. Rotary control valve actuator
4. Steam distribution system
5. Mounting set for insulated ducts*
6. Manometer*
7. Coupling piece for multiple piping*

Operating range for steam humidification systems Condair Esco, type DR73 and DL40:

Primary steam pressure (for live steam):	0,2...4,0 bar
Primary steam temperature:	104...152 °C
Max. ambient temperature:	50 °C
Max. ambient humidity:	98 % r.h.

Text for tendering

<p>Steam humidification system Condair Esco Steam humidifier for connection to an existing steam supply, consisting of:</p> <ul style="list-style-type: none"> • Connection unit with flanged connection, steam-tight ceramic rotary-disk control valve, strainer, separation chamber and primary spheric float steam trap • Steam distribution pipe, with steam nozzles, for a uniform discharge of live steam into air current throughout the entire length of the pipe, and thermal secondary condensate drain • Electric rotary actuator for connection to all commercially available humidity controllers 																						
<p>Type DR73 Steam humidification system consisting of: connection unit, electric rotary actuator, horizontal main distribution pipe with condensate drain pipe, and vertically arranged secondary pipes with steam nozzles.</p>	<p>Type DL40 Steam humidification system consisting of: connection unit, electric rotary actuator, horizontal steam distribution pipe with steam nozzles and condensate drain pipe.</p>																					
<table border="0"> <tr> <td>Humidification capacity:</td> <td>.....</td> <td>kg/hr</td> </tr> <tr> <td>Primary steam overpressure:</td> <td>.....</td> <td>bar</td> </tr> <tr> <td>Humidity inlet/outlet:</td> <td>.....</td> <td>g/kg</td> </tr> <tr> <td>Air volume:</td> <td>.....</td> <td>m³/hr</td> </tr> </table>	Humidification capacity:	kg/hr	Primary steam overpressure:	bar	Humidity inlet/outlet:	g/kg	Air volume:	m ³ /hr	<table border="0"> <tr> <td>Duct width/height in light</td> <td>.....</td> <td>mm</td> </tr> <tr> <td>Min. inlet air temperature</td> <td>.....</td> <td>°C</td> </tr> <tr> <td>Max. humidification distance</td> <td>.....</td> <td>m</td> </tr> </table>	Duct width/height in light	mm	Min. inlet air temperature	°C	Max. humidification distance	m
Humidification capacity:	kg/hr																				
Primary steam overpressure:	bar																				
Humidity inlet/outlet:	g/kg																				
Air volume:	m ³ /hr																				
Duct width/height in light	mm																				
Min. inlet air temperature	°C																				
Max. humidification distance	m																				
<table border="0"> <tr> <td>Brand</td> <td>Condair Esco</td> </tr> <tr> <td>Type</td> <td>.....</td> </tr> <tr> <td>Supplier</td> <td>.....</td> </tr> </table>	Brand	Condair Esco	Type	Supplier																
Brand	Condair Esco																					
Type																					
Supplier																					
<p>Accessories, optional</p> <ul style="list-style-type: none"> • Manometer mounted to connection unit, for steam pressure 0 - 2.5 bar • Manometer mounted to connection unit, for steam pressure 0 - 6.0 bar • Mounting set for insulated ducts / AHU's • Coupling pieces for multiple piping (only type DL40) 																						

Tabular overview of standard components and options

Standard Components	Connection unit for max. steam capacity see chapter 3.2 and 3.7	Esco 5 up to 127 kg/hr		Esco 10 up to 250 kg/hr		Esco 20 up to 500 kg/hr		Esco 30 up to 1000 kg/hr	
	Ceramic- rotary-disk control valve see chapter 3.2 and 3.7	7 valve sizes 5-1 to 5-7		10 valve sizes 10-1 to 10-10		4 valve sizes 20-1 to 20-4		4 valve sizes 30-1 to 30-4	
	Steam distribution type see chapter 3.4 and 3.7	DR73 not possible	DL40	DR73	DL40	DR73	DL40	DR73	DL40 not possible
	rotary-disk contr. valve actuator see chapter 3.3 Condair CA75		●		●				
	Condair CA150A		●	●	●	●	●	●	
	Condair CA150A-S		●	●	●	●	●	●	
	Condair P10		●	●	●	●	●	●	
Options	Mounting set for insulated ducts/AHU's (see chapter 3.5)		●	●	●	●	●	●	
	Manometer see chapter 3.6 Display 0 to 2,5 bar			● 1)	● 1)	● 1)	● 1)	● 1)	
	Display 0 to 6,0 bar			● 1)	● 1)	● 1)	● 1)	● 1)	
	Coupling pieces for multiple piping see chapter 3.4.2 2 x steam distrib. pipe type 10/ 3 x steam distrib. pipe type 10/.				● ●		● ●		

1) retrofitable

3.2 Connection unit and ceramic rotary-disk control valve

- **Connection unit Esco 10, 20 and 30**
- **Ceramic rotary-disk control valve**
Characteristic curve for 18 different valve sizes, depending on humidification capacity and steam pressure

Example:

- Required humidification capacity: 100 kg/hr
- Available steam pressure: 1.5 bar

The intersection of the two “search lines” for the connection unit is located in the Esco 10 diagram between the characteristic curves 10/7 and 10/8.

- Esco 10 with valve size 10/7 provides 76 kg/hr
- Esco 10 with valve size 10/8 provides 120 kg/hr

The HVAC engineer will select one of the two possible valves:

- the **Esco 10-10/7**, if it is permissible for the “comfort” humidification to be somewhat lower, in favour of optimal controllability during the remainder of the operating time.
- the **Esco 10-10/8**, if the humidity requirements were calculated rather tightly, or if a certain application in process technology requires the max. steam capacity.

With the rotary control valve actuator CA150A, the steam output can be limited to the actual system requirement. Without this limitation, the steam boiler output must be dimensioned to correspond with the max. steam capacity of the ceramic rotary-disk control valve.

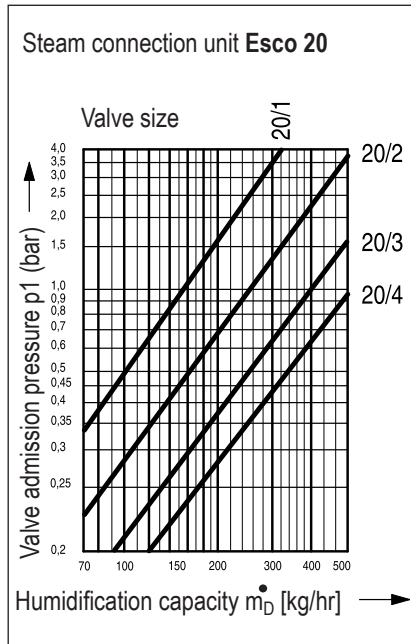

Selection diagram for dimensioning the connection unit **Esco 20** with the corresponding valve size.

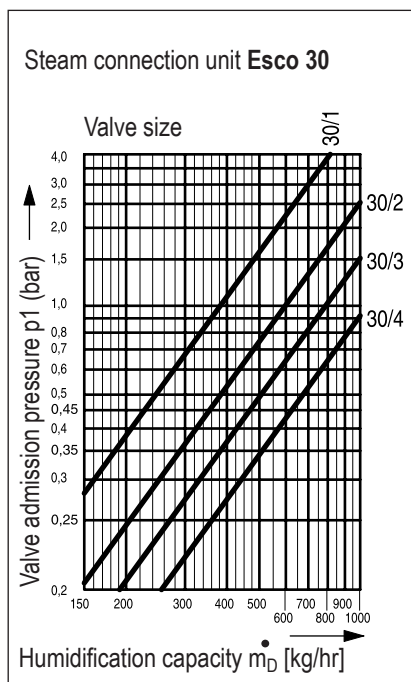

Selection diagram for dimensioning the connection unit **Esco 30** with the corresponding valve size.

Note:

The computer dimensioning program will always select the larger valve size.

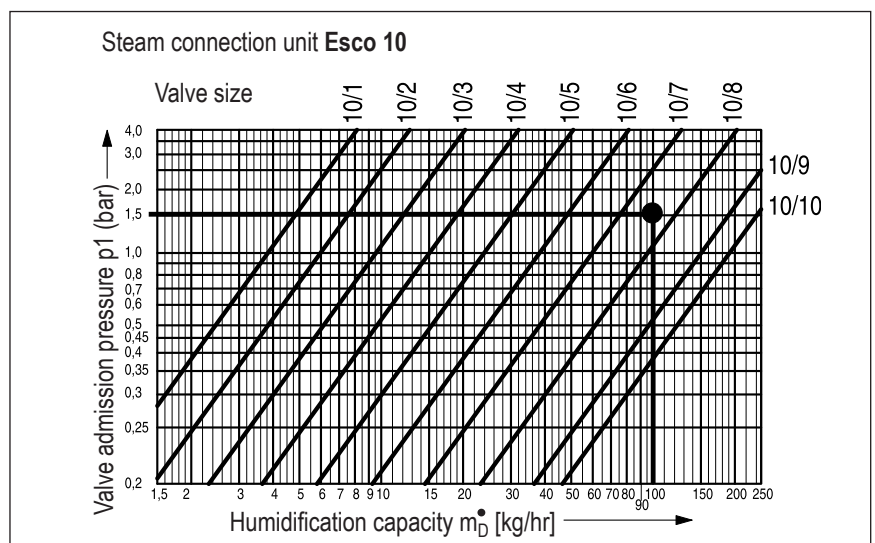

Selection diagram for dimensioning the connection unit **Esco 10** with the corresponding valve size.

3.3 Rotary control valve actuator

The steam humidification system Condair Esco is supplied with an electric Condair rotary actuator as standard equipment. As desired, the rotary control valve actuator comes either with (CA150A/CA150A-S) or without (CA75) attached spring-loaded return device (emergency function).

By using special adapter parts, other commercially available rotary control valve actuators can be employed as well.

ATTENTION/IMPORTANT



Rotary control valve actuators without spring-loaded return device (Condair CA75 or other makes) require additional on-site safety installations, in case the control voltage is lost (emergency stand-by voltage, auxiliary valve with automatic shut-off function). To prevent malfunction of the valve, **all electrical connections** of the rotary actuators must be properly wired to the connector box.



Electric rotary control valve actuator Condair CA150A and CA150A-S

Version:

Actuator housing: ground and cover plate made of metal with ultrasonic welded plastic housing, **emergency function by means of spring-loaded return device**, suitable for direct attachment to all Esco connection units. In addition, type CA150A-S comes with an adjustable and a fixed auxiliary switch. They are used to signal rotation angles of 10° or 10...90° respectively.

The regulating range of the electric rotary control valve actuators starts at a control signal of 2 VDC. However, because the ceramic rotary disks overlap in their closed state (to ensure absolute tightness), the valve starts opening at a signal value of 3 VDC.

Specifications:

	CA150A	CA150A-S
Supply voltage	24 VDC or 24 VAC / 50/60 Hz / Power consumption 7 VA	
Emergency function	by spring-loaded return device if supply voltage fails	
Control signal Y	Y1: 0-10 VDC	
Input impedance	Y1: 100 kΩ (0,1 mA)	
Operating range	Y1: 2-10 VDC	
Measuring voltage U	2-10 VDC (max. 0,5 mA)	
Torque / run time	20 Nm / motor: 150 s, spring return: 20 s	
Auxiliary switch potential free	none	2 x EPU 1mA...3(0.5)A
Protection class / System of protection	III (extra-low safety voltage), CE / IP 54 (drip-proof)	
Position indicator	mechanical	
max. permissible steam temperature	152 °C	
Ambient temperature	-30 ... +50 °C	
Ambient humidity	classe D in accordance with DIN 40040	
Weight	2100 g	

Electric rotary control valve actuator Condair CA75 without emergency function

Version:

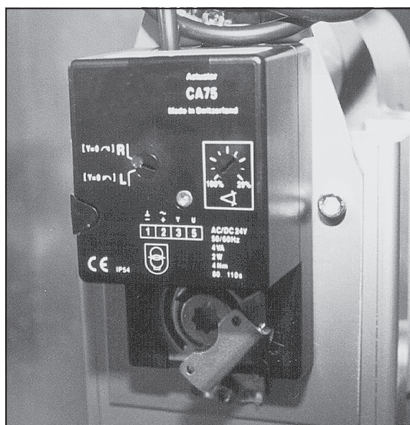

Actuator housing made of plastic, **without emergency function**, with electrically limited 90° rotation angle, **suitable only** for direct attachment to connection units **Esco 5 and Esco 10**. **Ideal for using in conjunction with low-capacity humidifiers to supplement humidification.**

Since the rotary control valve actuator Condair CA75 does not incorporate an emergency function, the responsibility for using it lies with the planning engineer. He must decide on the necessary safety measures in case of power loss, e.g. shut-off valve with spring-loaded return actuator, connected in series, or an emergency stand-by voltage supply.

Specifications:

	CA75
Supply voltage	24 VDC or 24 VAC / 50/60 Hz / Power consumption 2 VA
Control signal Y	0-10 VDC
Input impedance	100 kΩ (0,1 mA)
Operating range	2-10 VDC
Measuring voltage U	2-10 VDC (max. 0,5 mA)
Torque / run time	5 Nm / motor: 150 s
Auxiliary switch potential free	none
Protection class	III (extra-low safety voltage), CE / IP 54
Position indicator	mechanical
max. permissible steam temperature	152 °C
Ambient temperature	-30 ... +50 °C
Ambient humidity	Class D in accordance with DIN 40040
Weight	480 g

Adaptor for mounting rotary control valve actuators of different makes

The steam humidification system Condair Esco can be adapted to any commercially available rotary actuator makes, by using appropriate adaptor parts and accessories.

Before installing different rotary control valve actuators, the supplier must be contacted.

Adaptors are currently available for the following third-party electric rotary actuators:

- Sauter ASF 123 SF 122
- Siemens GCA 161.1E
- Joventa DM 1.1 F-R

**Pneumatic actuator type P10 for steam connection units
Condair Esco 5, 10, 20 and 30**

For continuous or on/off control of Condair Esco steam connection units. The actuators are equipped with a mounting panel and delivered completely together with the steam connection units.

Housing is of olive-yellow, self-extinguishing, glass-fibre-reinforced plastic; membrane of silicon; drive spindle of stainless steel; compressed-air connection RP 1/8", female thread.

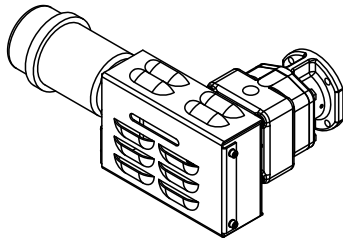

Pneumatic actuator P10 for Esco 5

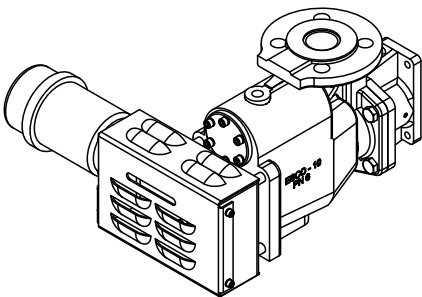

Pneumatic actuator P10 for Esco 10

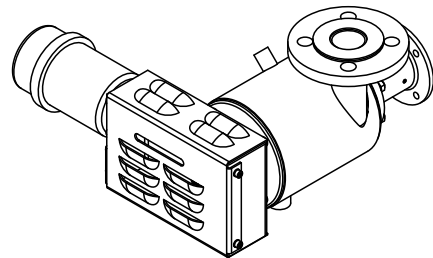

Pneumatic actuator P10 for Esco 10
stainless steel version

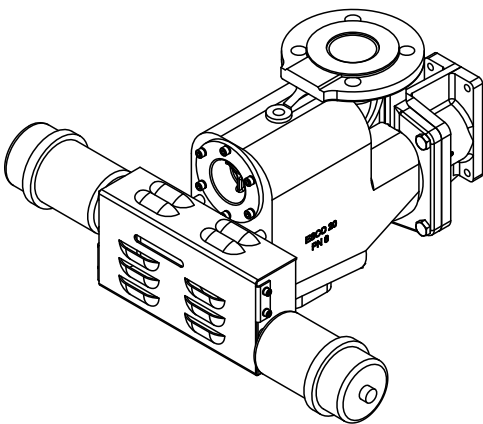

Pneumatic actuator P10 for Esco 20

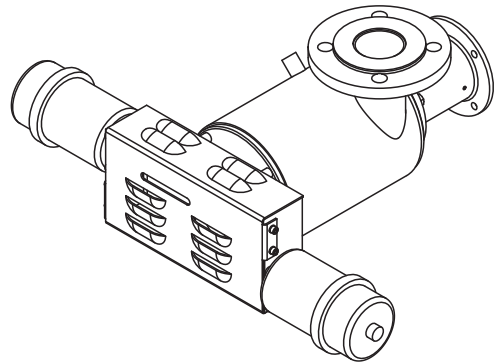

Pneumatic actuator P10 for Esco 20
stainless steel version

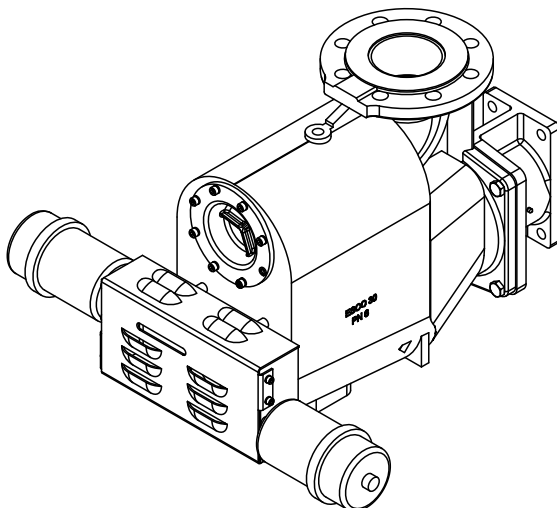

Pneumatic actuator P10 for Esco 30

Technical specifications:

Control pressure:	0...1.2 bar
Max. pressure:	1.5 bar
Working pressure range:	0.3...0.9 bar
Actuating power:	100 N
Stroke:	63 mm
Running time for 100% stroke:	7 s
Air consumption for 100% stroke:	0.5 I _n
Permissible ambient temperature:	-10...70 °C
Degree of protection:	IP 20

Accessory:**Pneumatic positioner XSP31 for actuator type P10**

Used to convert a continuous positioning signal y into the defined position of the pneumatic actuator P10.

The positioners capabilities:

- increases the positional accuracy
- divides up the positioning range, (e.g. sequence)
- increases the positional speed.

Execution:

Housing of light alloy; with two diaphragm cells and integrated pressure adjuster for setting the zero-point; double-armed lever for matching the unit to the type of drive and for setting the control span; control element of plastic, measuring connection M4 for the output pressure, compressed-air connection RP 1/8" female thread. Complete with assembly material.

If the pneumatic positioner for the valve unit is ordered together with the P10 actuator, these units are assembled and pe-adjusted at the factory.

Technical specifications:

Supply pressure:	1.3 ±0.1 bar
Max. control pressure:	1.4 bar
Adjustment range:	0.2...1.0 bar
Linearity:	1 %
Perm. ambient temperature:	0...70 °C
Degree of protection:	IP 54

Matrix stroke actuators P10 for Condair Esco steam connection units		
Type of steam connection unit	Pneumatic actuator P10	Positioner (optional)
Condair Esco 5	1	1
Condair Esco 10	1	1
Condair Esco 10, stainless steel version	1	1
Condair Esco 20	2	1
Condair Esco 20, stainless steel version	2	1
Condair Esco 30	2	1

3.4 Steam distribution

The steam humidification system Condair Esco offers two different types of steam distribution:

– Type DL40

Ideally suited for low duct or system cross-sections. The horizontal steam distribution pipe, with integrated nozzles, is especially useful for circulating air systems having a **low duct cross-section** and an **extended humidification zone**. Can be connected to the steam connection units Esco 10 and Esco 20.

With optionally available coupling pieces, multiple piping is possible with two or three steam distribution pipes arranged on top of, or next to each other.

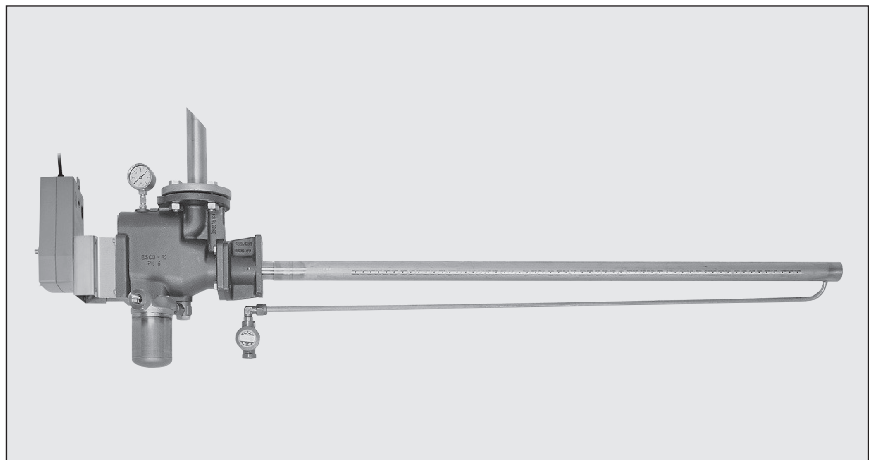

– Type DR73

Ideally suited for large fresh-air portions and high duct or system cross-sections. Vertical steam distribution pipes, with integrated nozzles, guarantee the **shortest possible humidification distance**, thanks to computer aided customised system design. Can be connected to all steam connection units.



3.4.1 Type DR73

There are different types of installations for the Condair Esco system DR73, which are explained in more detail below. Each one of these types may have a varying number of distribution pipes and different connection units. This is why the unit designation is comprised of the following components:

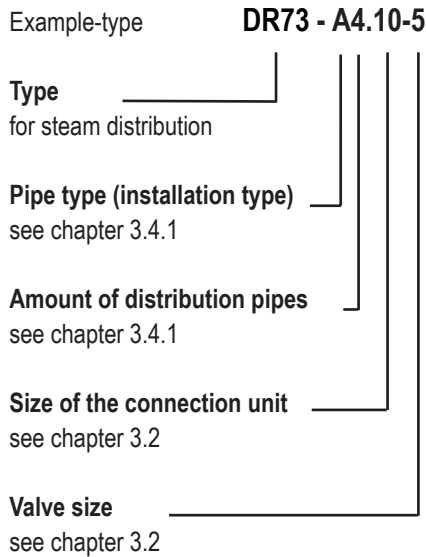

- **Pipe type (installation type)**

There is a choice of the following types:

- **Type A (Type JA)**

for installation in horizontal ducts or units **without** ground clearance

Type DR73 - A

Type DR73 - JA* from 488 kg/hr

Type DR73-J2A* from 2 x 488 kg/hr

(with 2 connection units Esco 30)

- **Type B (Type JB)**

for installation in horizontal ducts or units **with** ground clearance

Type DR73 - B

Type DR73 - JB* from 488 kg/hr

Type DR73 - J2B* from 2 x 488 kg/hr

(with 2 connection units Esco 30)

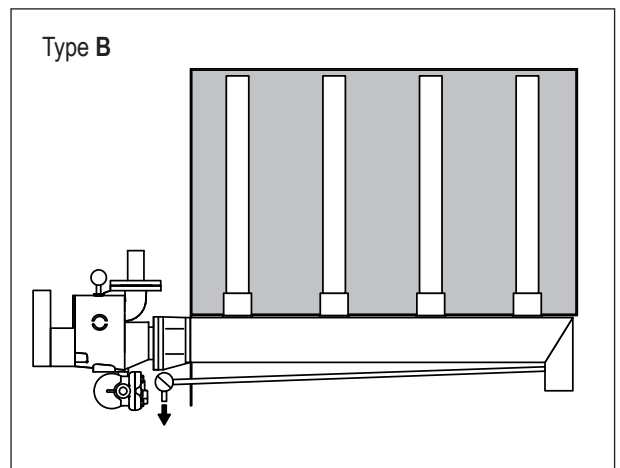
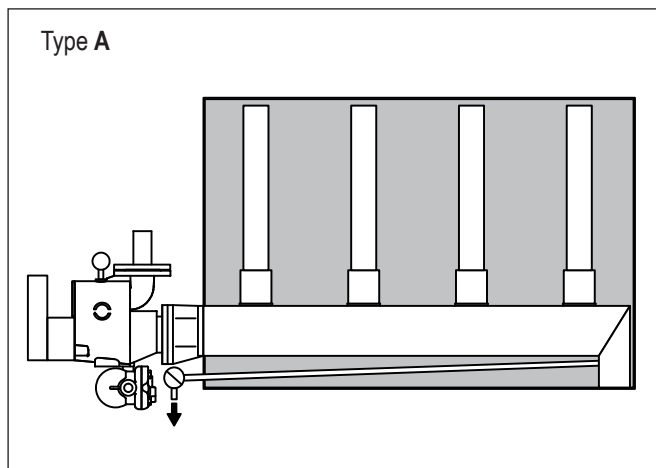

* Dimension diagrams for types DR73-J.. up on request

- Determining the number of steam distribution pipes types A, B and J*

Notes on the following selection diagrams

The following diagrams, used to determine the steam distribution pipes of both systems, are always based upon the shortest possible humidification distance. To calculate a cost-optimised system that selects the steam distribution pipes, based on a given humidification distance, is possible only with the computer program.

Table 1

Determining the number of steam distribution pipes in dependence of the duct height **b**, the air velocity **w** and the humidification capacity m_D .



Tabelle 2

Determining the number of steam distribution pipes in dependence of the air velocity **w** and the duct width **a**

Air-velocity w (m/s)	Number of steam distribution pipes											
	1		2		3		4		5		6	
	Duct width a (mm)		Duct width a (mm)		Duct width a (mm)		Duct width a (mm)		Duct width a (mm)		Duct width a (mm)	
	min.	max.	min.	max.	min.	max.	min.	max.	min.	max.	min.	max.
1 - 1,9	800	1100	900	1550	1000	2000	1100	2450	1200	2900	1300	3350
2 - 2,9	700	1000	800	1450	900	1900	1000	2350	1100	2800	1200	3250
3 - 3,9	600	900	700	1300	800	1700	900	2100	900	2500	1100	2900
4 - 4,9	500	800	600	1200	700	1600	800	2000	800	2400	1000	2800
5 - 7,4	400	700	500	1050	600	1400	700	1750	700	2100	900	2450
7,5 - 9,9	300	600	400	950	500	1300	600	1650	600	2000	800	2350

Air-velocity w (m/s)	Number of steam distribution pipes											
	7		8		9		10		11		12	
	Duct width a (mm)		Duct width a (mm)		Duct width a (mm)		Duct width a (mm)		Duct width a (mm)		Duct width a (mm)	
	min.	max.	min.	max.	min.	max.	min.	max.	min.	max.	min.	max.
1 - 1,9	1400	3800	1500	4250	1600	4700	1700	5150	1800	5600	1900	6000
2 - 2,9	1300	3700	1400	4150	1500	4600	1600	5050	1700	5500	1800	5950
3 - 3,9	1200	3300	1300	3700	1400	4100	1500	4500	1600	4900	1700	5300
4 - 4,9	1100	3200	1200	3600	1300	4000	1400	4400	1500	4800	1600	5200
5 - 7,4	1000	2800	1100	3150	1200	3500	1300	3850	1400	4200	1500	4550
7,5 - 9,9	900	2700	1000	3050	1100	3400	1200	3750	1300	4100	1400	4450

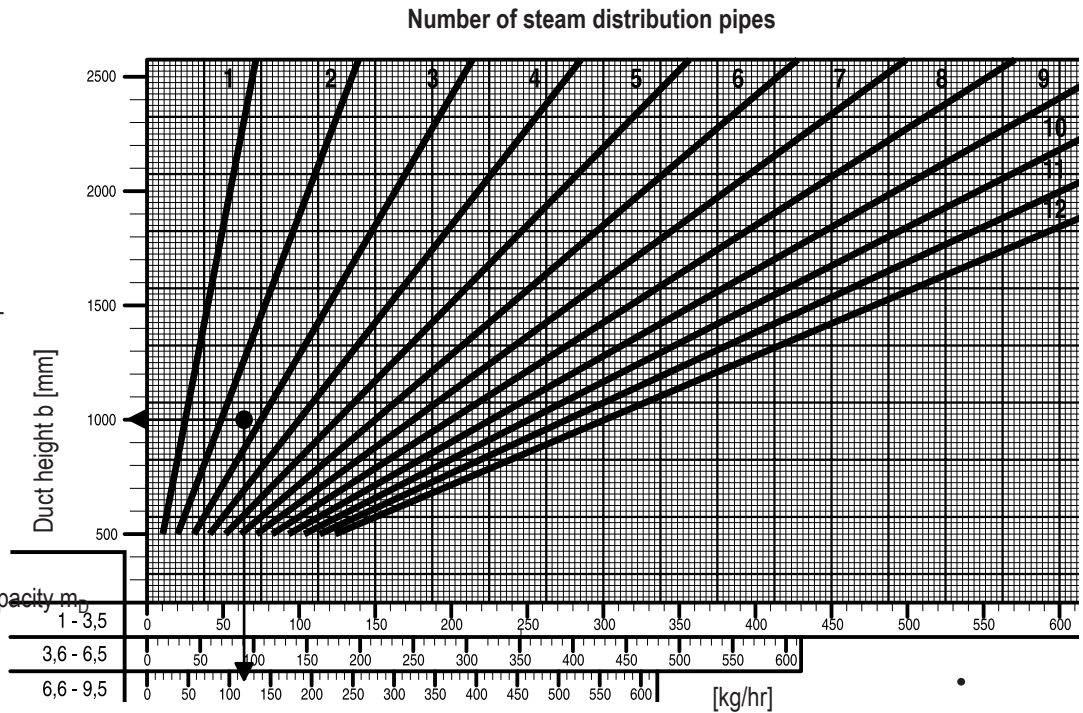
* Minimum duct height per type:

Type	min. height in mm
A	600
B	400
JA	800
JB	800

Example:

Duct height **b** = 1000 mm
 Duct width **a** = 1700 mm
 Humidification capacity m_D = 120 kg/hr
 Air velocity **w** = 7 m/s

From Table 1 = 3 (3 steam distribution pipes)
 From Table 2 = 4 (4 steam distribution pipes)

If the number of secondary pipes, calculated from the two tables, does **not** coincide, always select the **higher** number.

Result: **Type DR73 - ...4.20** → Size of the connection unit in accordance with chap. 3.2

* Note: Number of vertical pipes for J-types have to be divisible with two.

3.4.2 Type DL40

The steam humidification system Condair Esco, type DL40 uses a standardised steam distribution pipe, suitable for all injecting directions. The distribution pipes come in standard lengths and can be connected to connection units Esco 10 or Esco 20. The unit designation is comprised of the following components:

– **Pipe type**

Initially, the pipe types are selected on the basis of the air duct width. It must then be noted, that there is a maximum steam capacity that can be accommodated by a given length.

– **Multiple coupling pieces**

Where it is required by the **system** and permitted by the **available space**, **dual or triple piping is possible with steam distribution pipes arranged on top of, or next to each other. The connection units Esco 10 and Esco 20 are available with the matching coupling pieces, for a standard pipe spacing of 300 mm, 600 mm and 900 mm.**

For dimension diagrams refer to chap. 4.6.2.

Example-type **DL40-1-10/118-10-3**

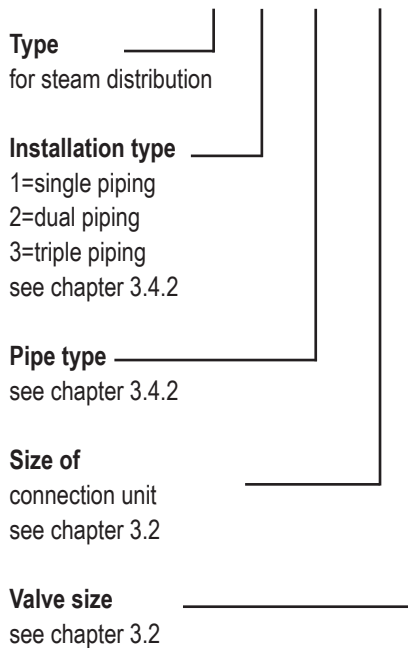

Steam-Connection unit [size]	Pipe for type DL40	Duct width [mm]	max. steam capacity [kg/hr]
10	10/023	250-399	16
	10/038	400-499	27
	10/048	500-599	32
	10/058	600-699	41
	10/068	700-899	50
	10/088	900-1199	62
	10/118	1200-1499	94
	10/148	1500-1799	118
	10/178	1800-2099	142
	10/208	2100-2399	187
	10/238	2400-2699	214
	10/268	2700-2999	241
	10/298	3000-3299	250
	10/328	3000-3599	250
20	20/058	600-899	41
	20/088	900-1199	62
	20/118	1200-1499	94
	20/488	1500-1799	118
	20/178	1800-2099	142
	20/208	2100-2399	187
	20/238	2400-2699	214
	20/268	2700-2999	241
	20/298	3000-3299	268
	20/328	3300-3599	295
20/358	3600-3899	322	
20/388	3900-4299	349	

3.5 Mounting set for insulated ducts and AHU's

There are distance-sleeves available to put through the insulation in order to fix and stabilize the steam connection units on the devices, (see picture). The tublets are delivered with length of 45 or 75 mm and can be easily cutted on site to the needed insulation thickness, according to the wall thickness of the duct/ahu.

For detailed information to the mounting set please see separate brochure "Condair Esco installation instructions".

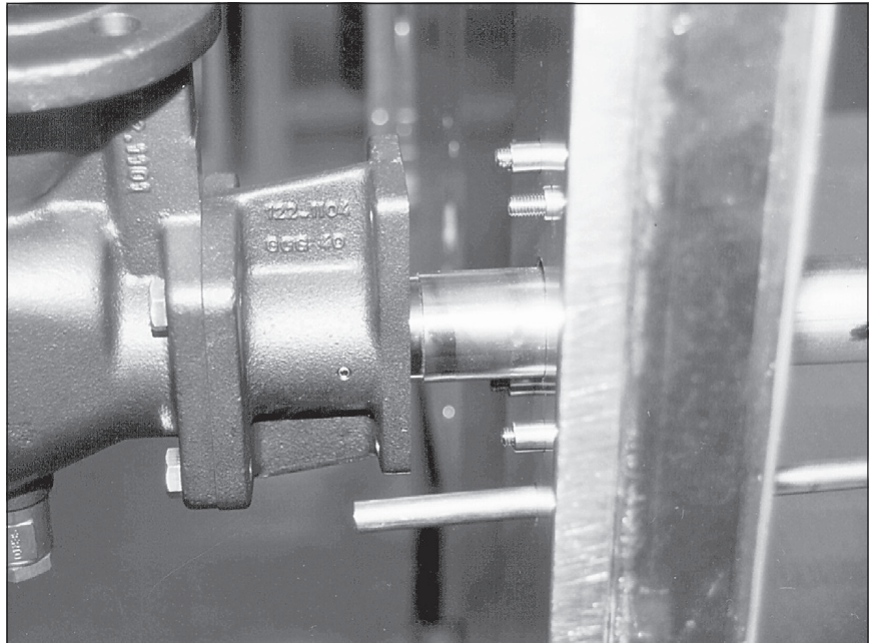
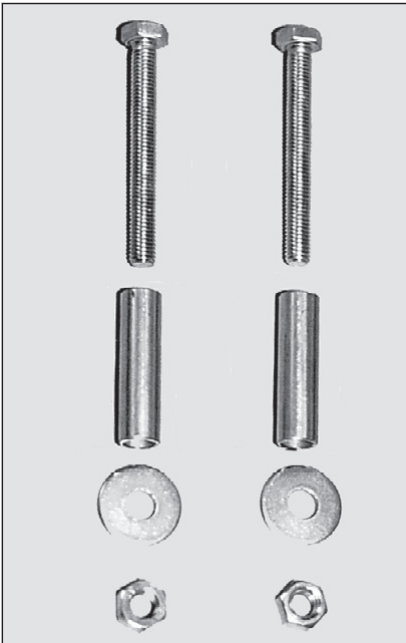

3.6 Manometer

All connection units Esco 10 - 30 may **optionally** be equipped with a **manometer**. This allows monitoring of the valve admission pressure during operation.

The selection of the appropriate manometer depends on the valve admission pressure:

– **Pressure display 0 - 2,5 bar**
for valve admission pressure
0,2 - 1,5 bar

– **Pressure display 0 - 6,0 bar**
for valve admission pressure
1,5 - 4,0 bar

For information on retrofitting individual components refer to the tabular overview in chapter 3.1.

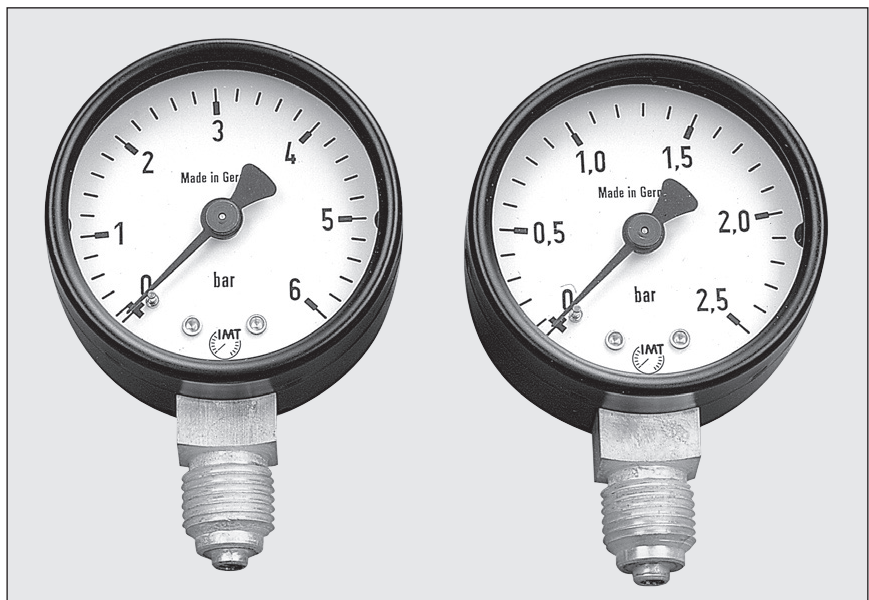

3.7 Condair Esco stainless steel

Condair Esco DL40 and DR73 steam humidifiers made entirely from high-grade steel

The steam connection unit

The rust-protected steam connection unit consists of an amply-dimensioned steam pressure relief compartment, in which a steam drier has been integrated. The steam is supplied to the valve in cycles. The condensate produced when starting the system is therefore separated at the steam drier and taken to the spheric float primary trap. This ensures that only dry steam flows through the valve. The steam inlet is flanged and is of welded design tested for strength.

Electrical rotary drives or a pneumatic actuator from the existing range can be fitted as required.

The steam connection units are supplied complete and ready for installation.

- steam capacity: maximum 500 kg/hr with
- steam overpressure: maximum 4.0 bars

The valve characteristic of the integrated ceramic rotary-disk valve corresponds to the performance of the Condair Esco 10 and Esco 20 steam connection unit (see selection diagram for Esco 10 or Esco 20 in chapter 3.2).

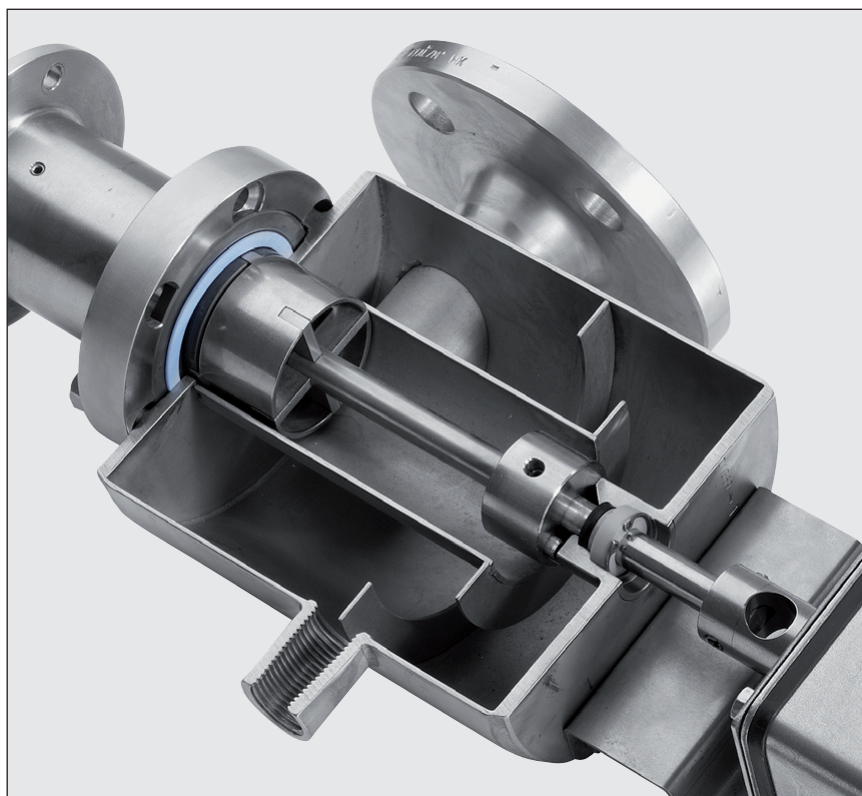

The steam distribution systems

The stainless steel steam connection unit has been developed for the connection to the:

- DL40 system: Single pipes 10/023...10/388 (see chapter 3.4.2)
Double and triple pipes (see chapter 4.6.2)
- DR73 system: Short absorption manifolds (see chapter 3.4.2)

The delivery of all steam distribution systems includes the stainless steel, thermostatic secondary steam trap.

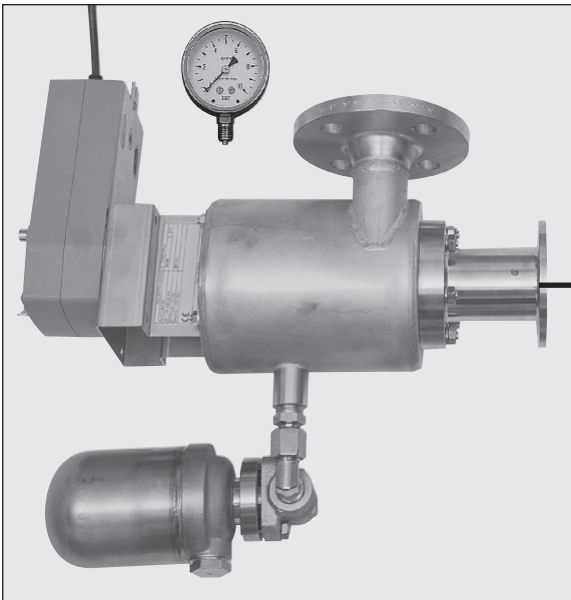

DL40 Single piping

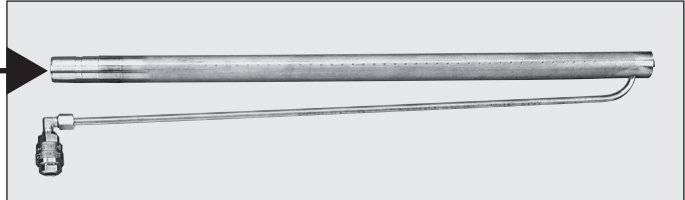

DL40 Double piping

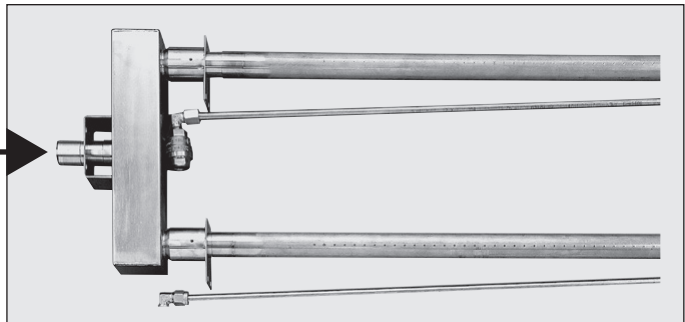

DR73 Multiple piping

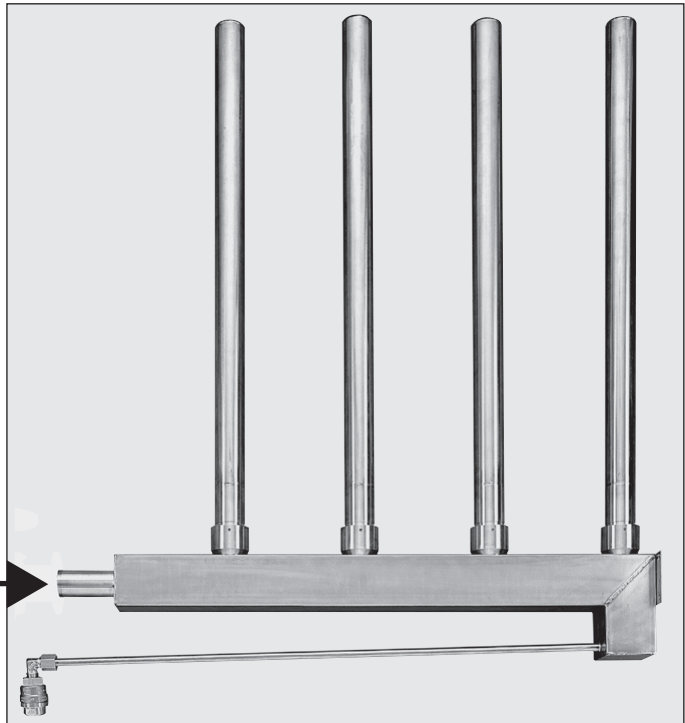

Primary steam trap

Standard: Spheric float condensate drain with stainless steel connector 0...4.0 bar or bell-shaped condensate drain with screw-type connector 0...1.5 bar or 1.5...4.0 bar

Optional: For steam capacities less than 100 kg/hr, a thermostatic primary steam trap can be used.

Tabular overview of Condair Esco stainless steel:
Standard components and options Esco 10 and Esco 20

Standard components	Steam connection unit for max. steam capacity see chapter 3.2	Esco 10 up to 250 kg/hr stainless steel		Esco 20 up to 500 kg/hr stainless steel	
	Ceramic rotary disk control valve see chapter 3.2	10 valve sizes 10-1 to 10-10		4 valve sizes 20-1 to 20-4	
	Steam distribution type see chapter 3.4	DR73	DL40	DR73	DL40
	Rotary control valve actuator see chapter 3.3 Condair CA75		●		
	Condair CA150A	●	●	●	●
	Condair CA150A-S	●	●	●	●
	Condair P10	●	●	●	●
Options	Mounting set for insulated ducts/AHU's see chapter 3.5	●	●	●	●
	Manometer Display 0 to 2,5 bar	● 1)	● 1)	● 1)	● 1)
	Display 0 to 6 bar	● 1)	● 1)	● 1)	● 1)
	Coupling pieces for Multiple piping see chapters 3.4.2 and 4.6.2 2 x steam distribution pipe Typ 10/. 3 x steam distribution pipe Typ 10/.		● ●		● ●

1) retrofitable

The robust industrial Bourdon tube pressure gauge with display

- 0...2.5 bar
- 0...6.0 bar

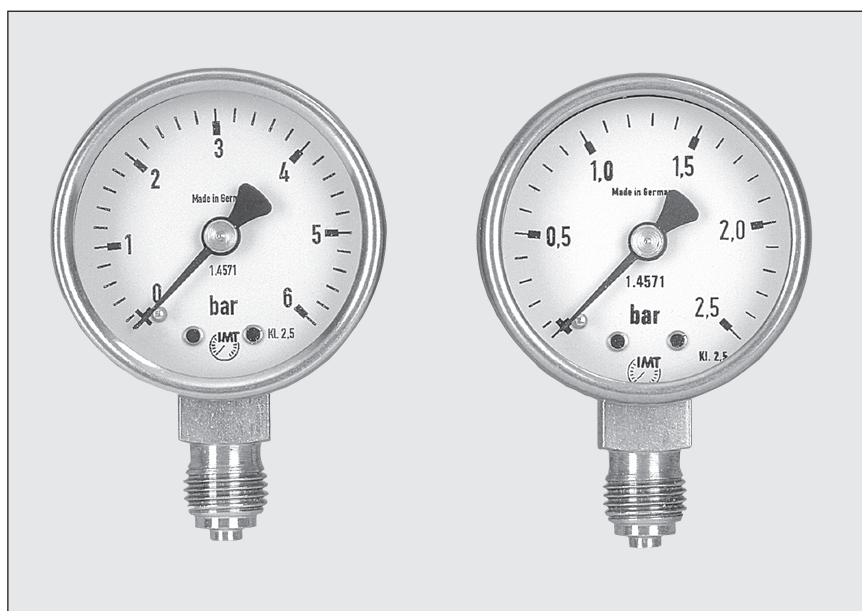

Material specification of the stainless steel components

DIN-W-No.:	Specification:
1.4301/1.4305	Steam connection unit (welded design)
1.4301	Steam inlet flange
1.4301	Flange for steam distribution systems
SIC	Ceramic rotary disk control valve
1.4301	Live spindle
1.4401	Compression spring
1.4305	Drive shaft
PEEK, (free from PTFE, silicone and halogens)	Bearing
EPDM/PTFE	O-rings
PTFE	Flat packing
1.4301	Nuts
1.4305	Cylindrical pins
1.4301	Bell-shaped primary float trap
1.4571	Connection screwing to spheric float drain
1.4305	Thermostatic primary and secondary steam trap
1.4305	Connection screwing to secondary steam trap
1.4571	Manometer
1.4301	Steam distribution system DR73 and DL40

Steam connection flange for steam distribution systems, Flange measurements

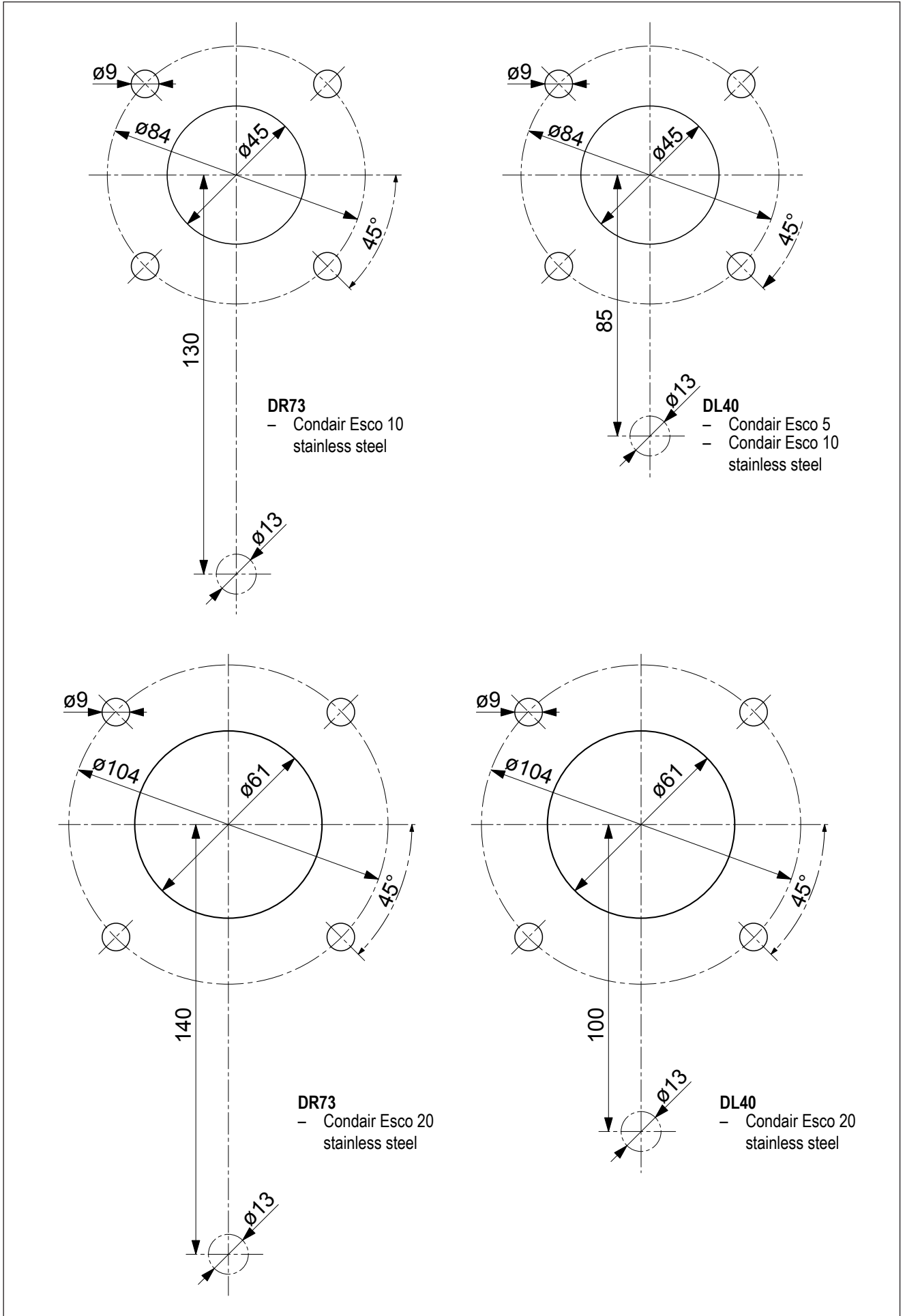

Dimension diagrams

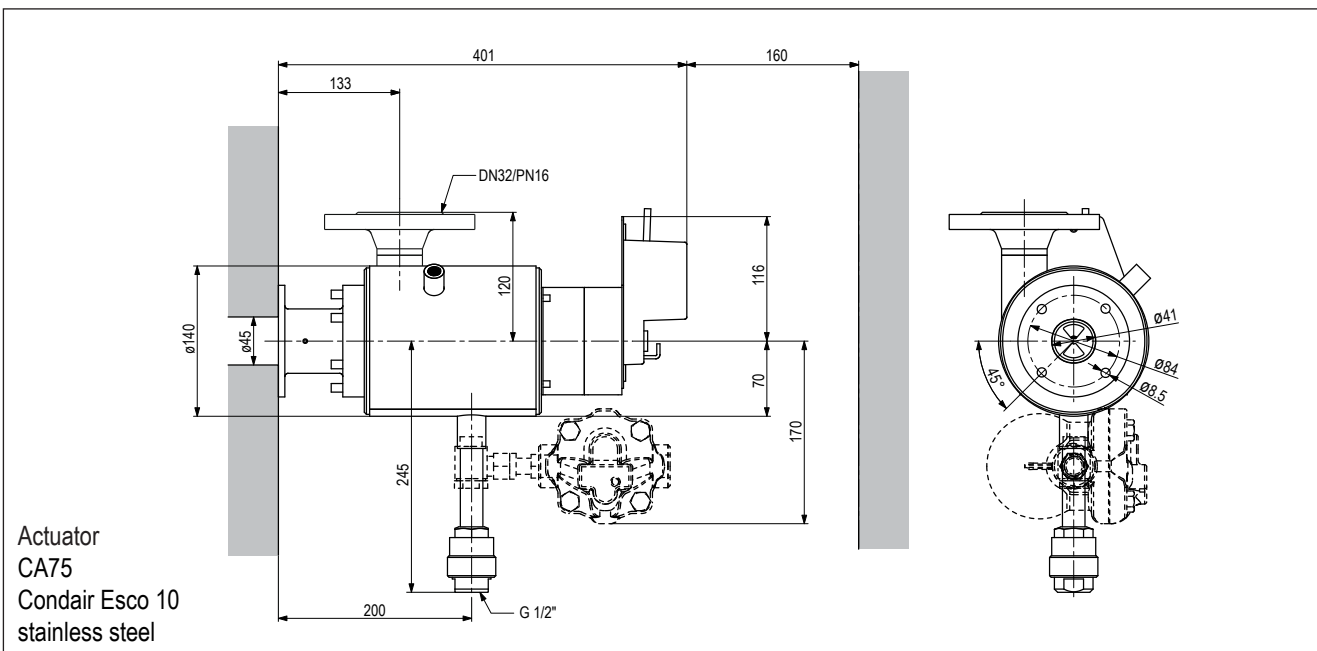
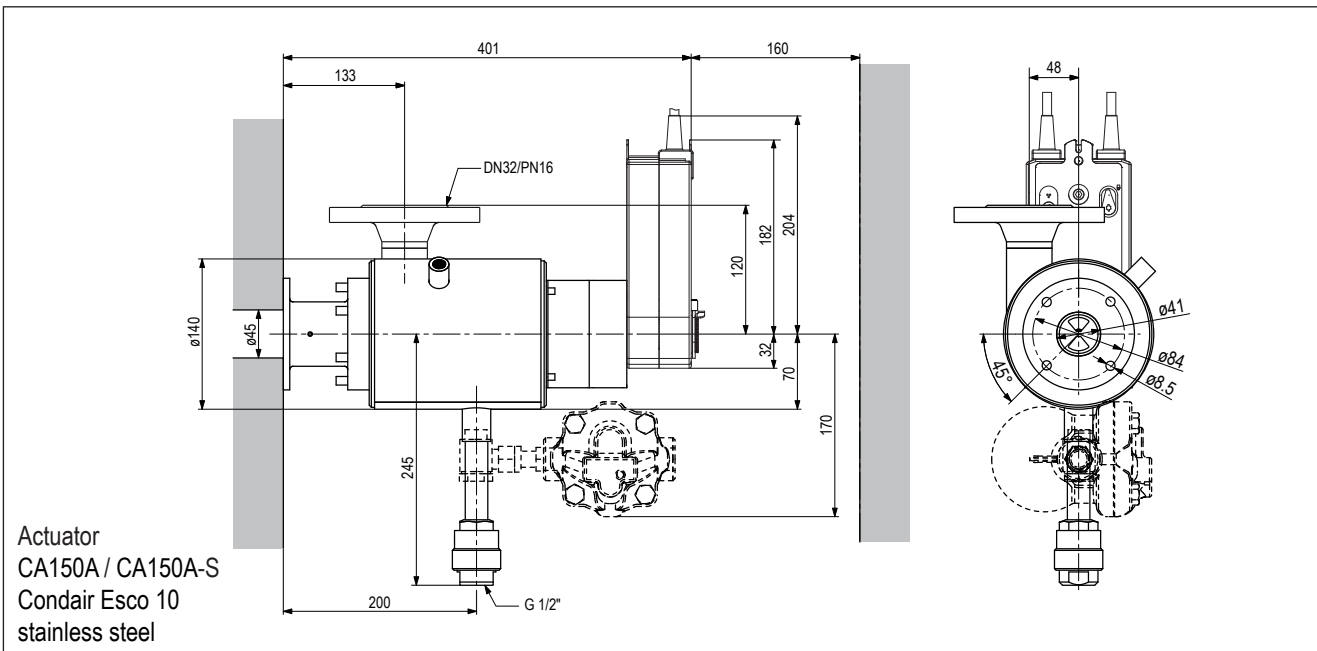
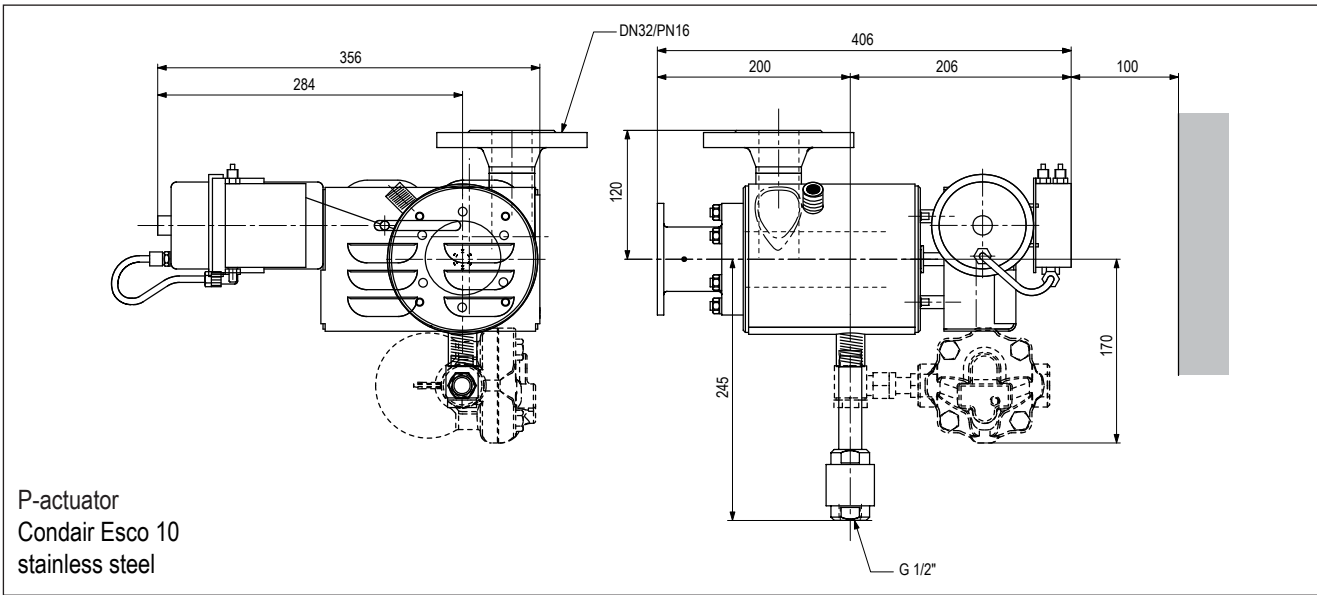

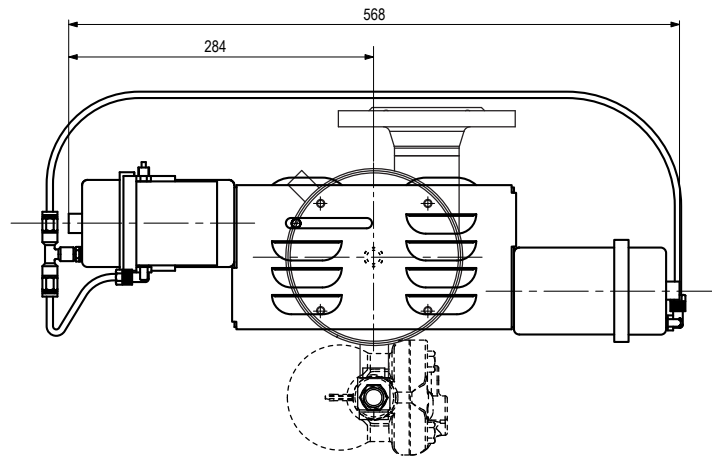
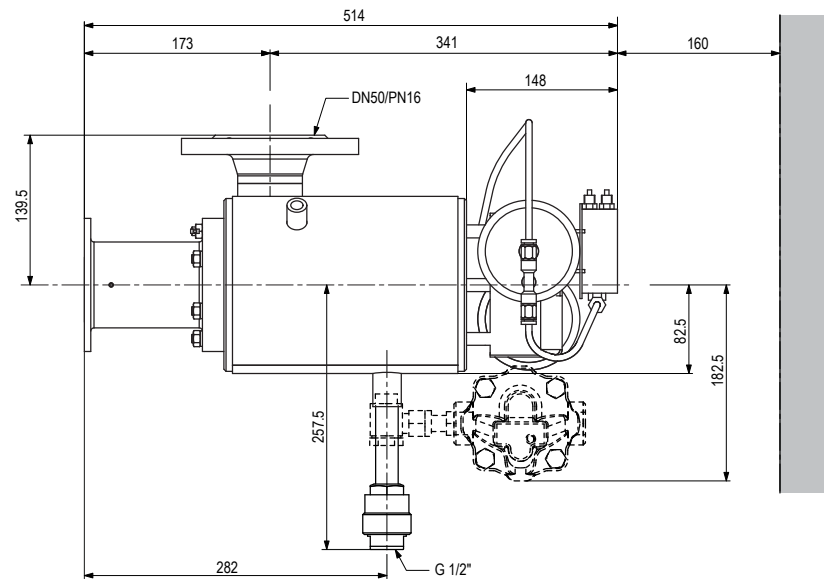

P-actuator
Condair Esco20
stainless steel

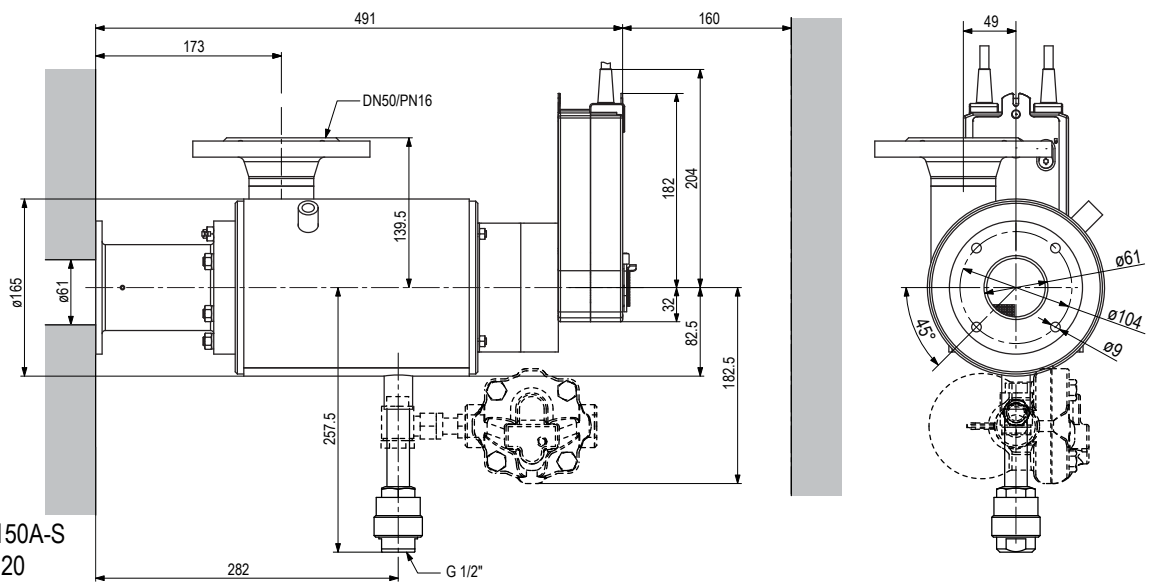

Actuator
CA150A / CA150A-S
Condair Esco 20
stainless steel

4 Hints for the consulting engineer and the HVAC technician

4.1 The use of steam in air humidification

To use steam from an existing steam boiler system, for the humidification of air, constitutes an actual consumption of energy and steam, whereas with steam heating, only the heat energy of the steam is utilised, and the condensate is recycled. Because steam is removed from the existing network, different operating conditions from those usually encountered are often created in the boiler house. This subject deserves a few remarks from actual practice.

– Feed-water conditioning

The **capacity** of the feed-water conditioning system **must be adjusted** to the future steam withdrawal rate. Furthermore, it is necessary to ensure trouble-free operation by carrying out **regular maintenance**. **Feed-water additives must not be allowed to exceed** the values for permissible concentration in the room air. One must also **keep in mind** the possibility of **odours being created** by feed-water additives or by contamination of the steam.

– Feed-water pump

The **pump capacity** must **be suited** for the additional steam withdrawal.

– Steam generation

All **steam boilers** that permit efficient steam withdrawal, from a sufficiently **large steam chamber**, are suitable. Continuous flow heaters and flash steam boilers are, as a rule, unsuitable.

– Boiler flushing

The continuous **withdrawal of steam** for air humidification **raises** the concentration of **residues**. **Periodic and adequate flushing is the only way** to avoid steam odour.

– Heat content of the steam

Does air humidification with steam affect the temperature of an air-conditioned room?

The **purpose** of humidification is to **increase the water vapour content** of the air. While the heat content of water vapour, contained in the air, is approx. 2550 kJ/kg, that of introduced steam usually amounts to about 2675 kJ/kg. The result is only a **slight increase of the air temperature** of approx. 0.1 °C, based on a specific humidification rate of 1 g per kg of air. This hardly results in an **additional temperature increase**, except perhaps by heat radiation.

– How “dry” does the steam have to be for air humidification?

The **task** of a steam humidifier **is to introduce** condensate-free, “**dry**” **water vapour**, from the existing steam supply, into the air, at a rate which is controlled by the required humidity. This effectively prevents corrosion, growth of bacteria and algae, and the development of odours in air ducts. **Drop collectors** and **drainage facilities** are **unnecessary** (see chapter 4.4).

4.2 Installation instructions

On the theory of humidification

The air's ability to absorb water vapour is dependent upon the prevailing conditions of the air. It can be determined from the h-x diagram as the difference between the saturated condition x_S and the water vapour content x_1 before humidification. **Standard practice in air conditioning is to always maintain a certain safety margin between the air condition x_2 , after humidification, and the saturated condition x_S (=100% relative humidity), to avoid the risk of condensation in the ducts. This danger is reinforced further by the following factors:**

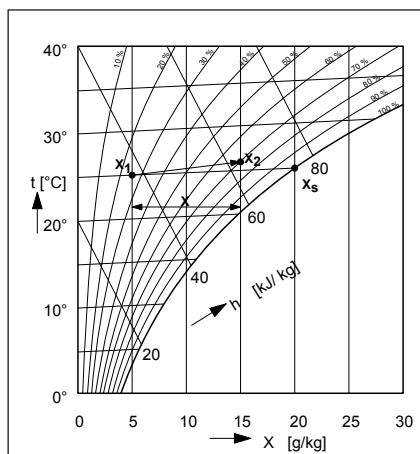

- Supply-air temperature fluctuations prior to humidification, because with lowering temperature, the state of saturation x_S may drop below the computed value for the state of saturation x_2 (humidification based on humidifier performance),
- Humidity control system is not consistently adjusting to less than full capacity requirements during transitional periods.
- **Restricting factors** (e.g. contaminated air filters) may **greatly reduce the operating air volume.**
- When air ducts pass through cooler rooms, not x_S at room temperature **is relevant**, but rather at the **duct's inner wall temperature**, which might drop below the dew point.

These obvious physical relationships in air conditioning technology express why condensation may occur in air ducts. **Air will always absorb humidity**, offered in the form of **water vapour**, but not beyond the limit set by the **saturated condition**.

4.3 Using the humidification distance diagrams

Please pay **close attention** to the following **diagrams**, and strictly observe the distances to downstream obstacles, when using the steam humidification system Condair Esco. This way only, can you be **assured**, that the steam is absorbed by the air and **no formation of condensate** on individual system components **takes place**.

However, the exact calculation of the guaranteed humidification distance, for the steam distribution system DR73, is only possible by means of the **computer dimensioning software**.

4.3.1 Type DR73

The **conical discharge** of steam at a **right angle to the air current**, and the variable arrangement of the steam pipes (illustration 1), account for the very high steam resolution achieved with the distribution pipes type DR73. **Steam therefore is absorbed by the air after a relatively short distance**; accordingly, the humidification distances to a downstream obstacle or the measuring point are also short.

As depicted in **illustration 1**, the **arrangement and distribution** of the steam outlet openings of the distribution pipe DR73 is **identical to that of a spray nozzle air humidifier**. Furthermore, compared to most commercial steam humidifiers, the steam pipes are **spaced considerably closer**, so the max. steam mass flow per meter of distribution pipe is substantially reduced.

To compute the humidification distances B_N , B_F or B_S to the respective **obstacles** and B_M to the **measuring point** (in accordance with illustrations 2-5), and the “terminology of the humidification distance”, the aforementioned optimal steam distribution and the following values are essential:

- Air velocity w
- Humidity x_1 before humidifier
- Humidity increase Δx
- Air temperature t before humidification
- Type of downstream obstacle and measuring point

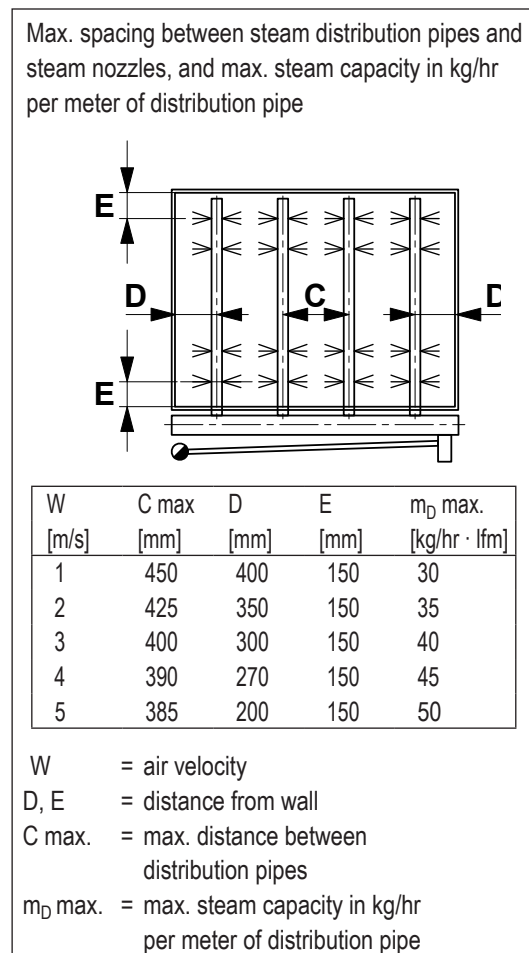
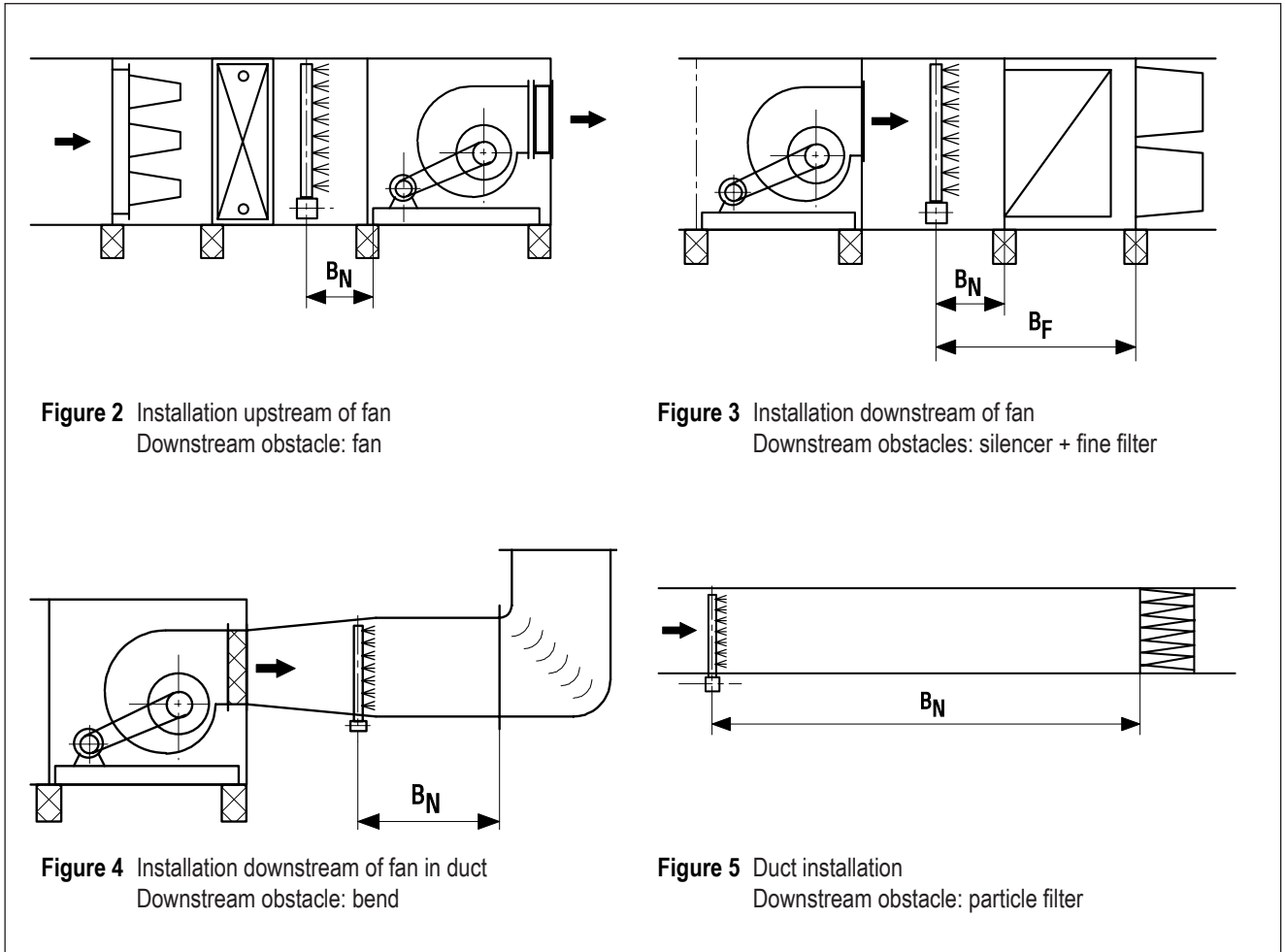

Figure 1

In the humidification distance diagram 1, empirically calculated standard values, based on lab tests, are used to express the humidification distances B_N , B_F or B_S to downstream obstacles in dependence of the above mentioned values. The air temperature t , before the distribution pipe, must not fall below the given values t_{min} , in order to avoid supersaturating the air (N), which causes wetting of the filters (F, S) when the relative humidity is increased accordingly.

The maximum steam mass flow -the most important prerequisite for determining the humidification distance- is based on the steam pipe dimensioning on page 26.



Terminology of the humidification distance

Example for operation with outside air:

- Air velocity $w = 3 \text{ m/s}$
- Air temperature before humidifier $t = 13^\circ\text{C}$
- Humidity increase $\Delta x = 6 \text{ g/kg}$
- Closest obstacle: fine filter F

Result:

Humidification distance
(from diagram): $B_F \approx 2,3 \text{ m}$

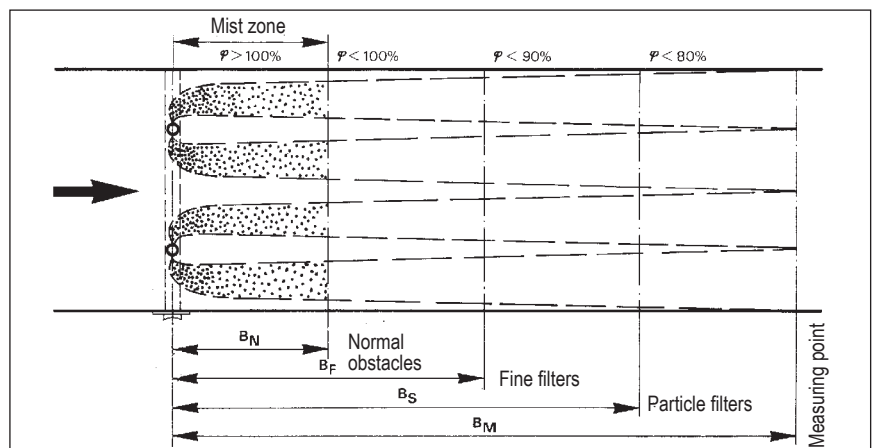

Humidification distance - diagrams 1

Diagram for calculating the distance to a downstream obstacle in **fresh** air operation, $x_1 = 1$ g/kg

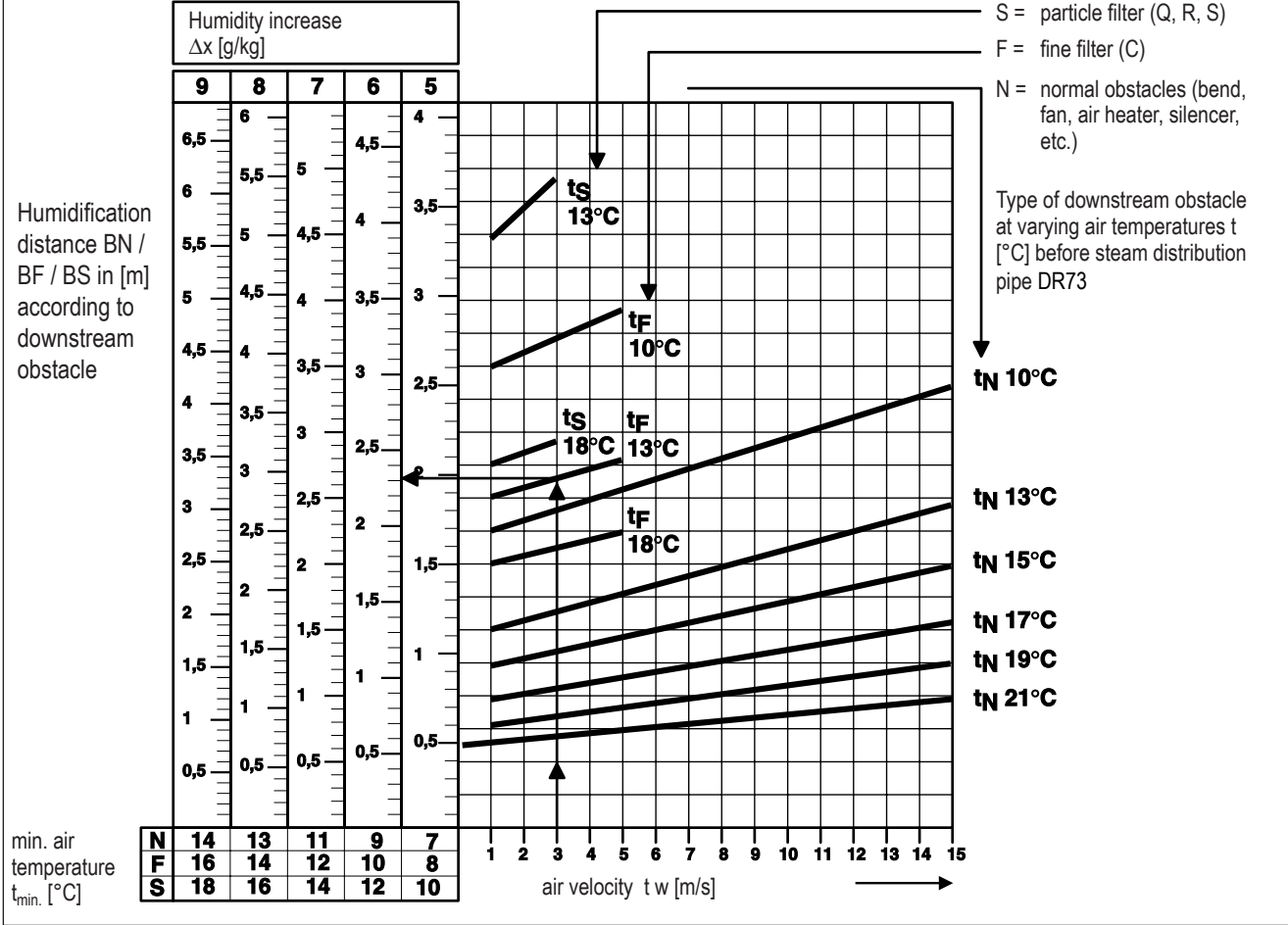
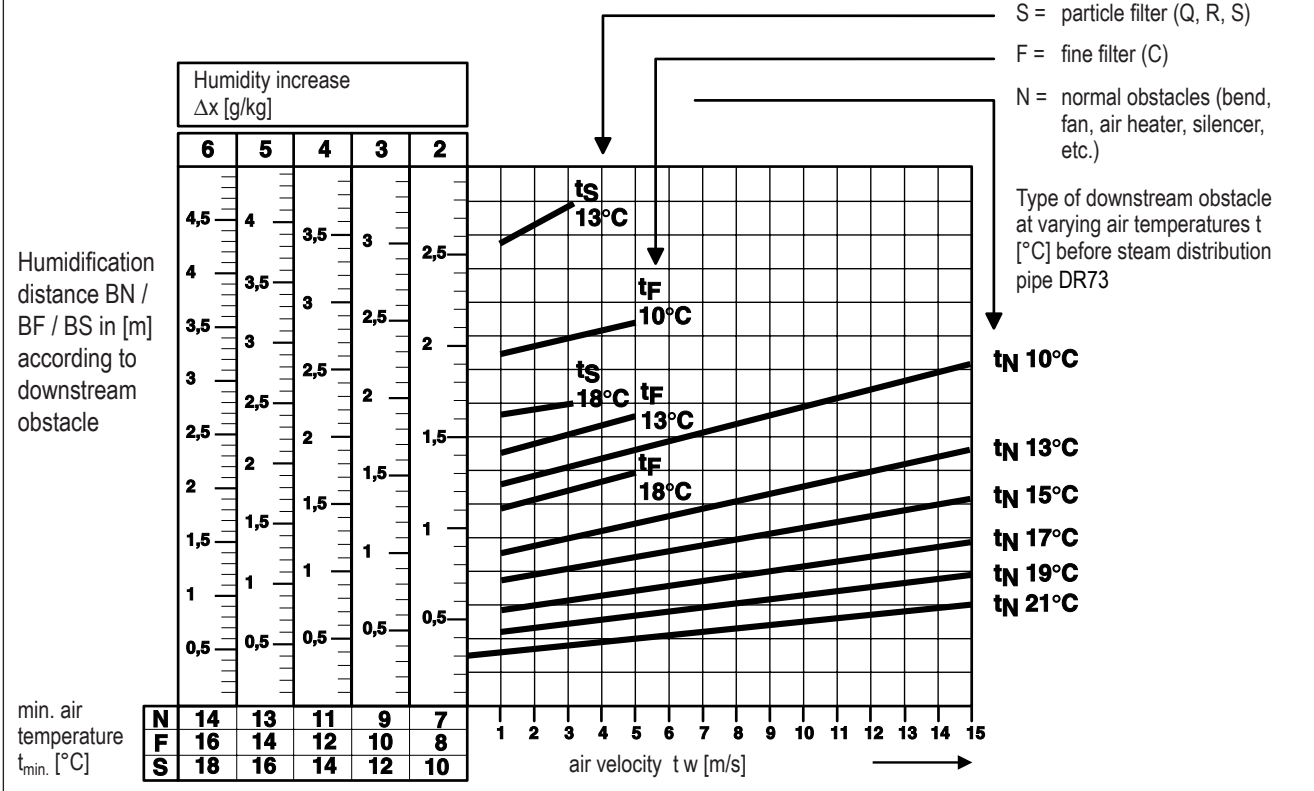

Diagram for calculating the distance to a downstream obstacle in **circulating** air operation, $x_1 = 4$ g/kg



Location of the humidity sensor to calculate the measuring point distance

Using the diagram below, the humidification distance between the steam distribution pipe and the measuring point, in dependence of the air velocity w and the humidity increase Δx can be determined.

Computing the distance to the measuring point or to the downstream obstacles presents two totally different physical problems:

At the measuring point, the measured value must correspond to the humidity mean value and occasional fluctuations, caused by turbulence, must not exceed a certain value.

As regards the obstacles, a distance must be observed which guarantees that **no water droplets**, temporarily formed past the discharge point (mist zone), collide with the obstacle only **to be eliminated as condensate**.

Example:

Air velocity	$w = 3,5 \text{ m/s}$
Humidity increase	$\Delta x = 4,5 \text{ g/kg}$
Humidific. distance (from diagram) to measuring point	$B_M \approx 6,4 \text{ m}$

This diagram is only to be used in conjunction with the steam distribution system type DR73.

Humidification distances B_M , computed from this diagram, are valid only for measuring points located in duct humidity control systems. They are meant to be recommendations for installing companies and control specialists.

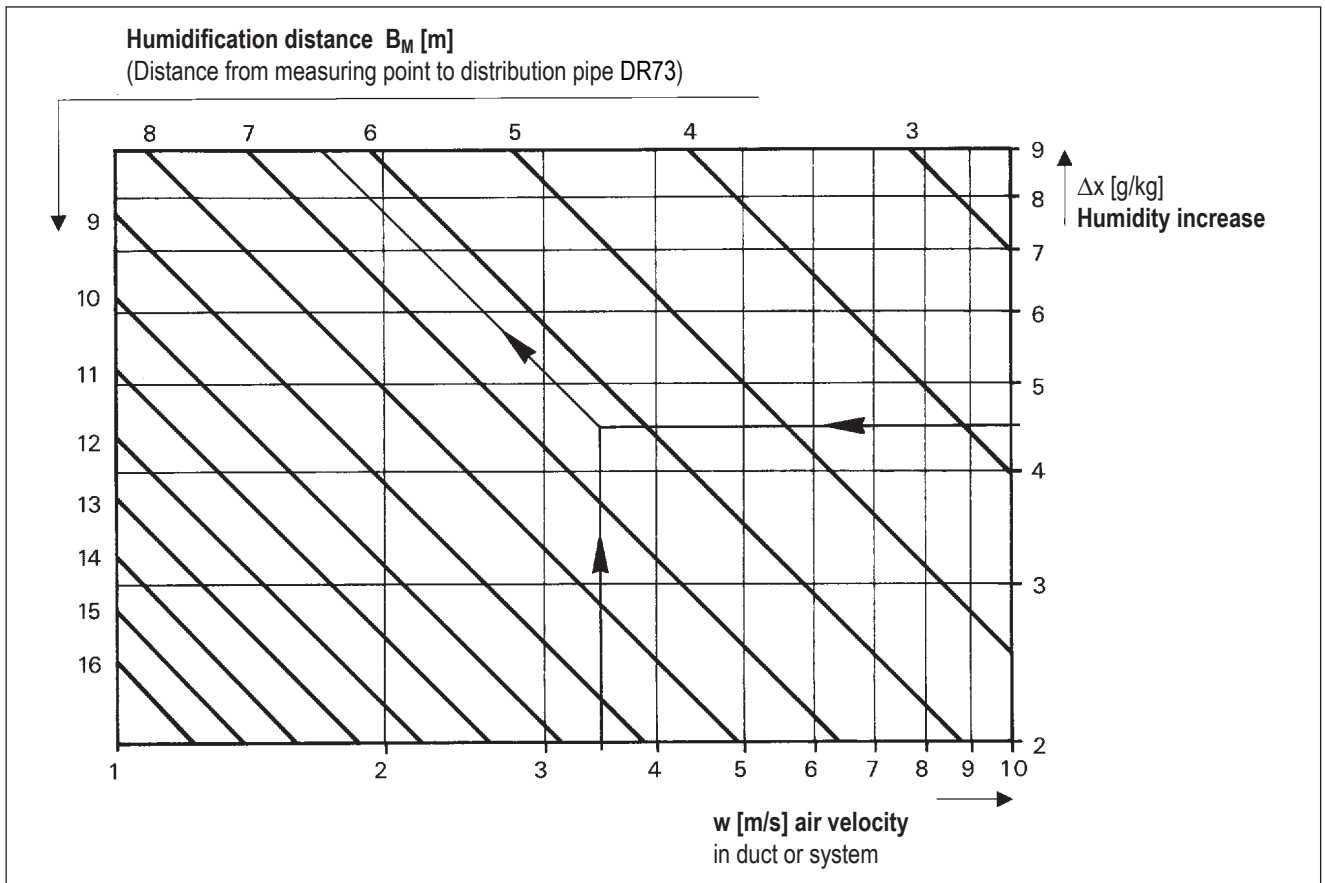

4.3.2 Type DL40

From the following humidification distance diagram 2, the extension factor as compared to type DR73 can be found and with its help the required humidification distance to the downstream obstacles determined. If this turns out to be too long, the steam humidification system Condair Esco DR73 is to be chosen in order to avoid the formation of condensate.

Humidification distance diagram 2

Diagram for determining the distance to a downstream obstacle **in circulating air operation, $x_1 = 1 \text{ g/kg}$**

Example:

Humidity increase	$\Delta x = 5 \text{ g/kg}$
Steam distribution pipe	$L = 1,8 \text{ m}$
Air velocity	$w = 3 \text{ m/s}$
Actual steam mass flow	$m_D = 108 \text{ kg/hr}$
Duct height/width	$= 0,9/1,9 \text{ m}$
Air temperature	$= 19 \text{ }^\circ\text{C}$

Calculation:

The air velocity w determines the rated load per meter of steam distribution pipe (40 kg/hr). The actual load per meter of steam distribution pipe is calculated from:

$$\frac{m_D (108 \text{ kg/hr})}{L (1,8 \text{ m})} = 60 \text{ kg/hr per meter}$$

Continuation from this intersection in the diagram is self explanatory.

Applying the same parameters, the humidification distance is now calculated from diagram 1 (type DR73) and the two results multiplied with each other:

Humidification distance from Humidification distance diagram 1: **0,75 m**

Extension factor from Humidification distance diagram 2: **1,8**

Humidification distance DL40:
 $0,75 \text{ m} \times 1,8 = 1,35 \text{ m}$

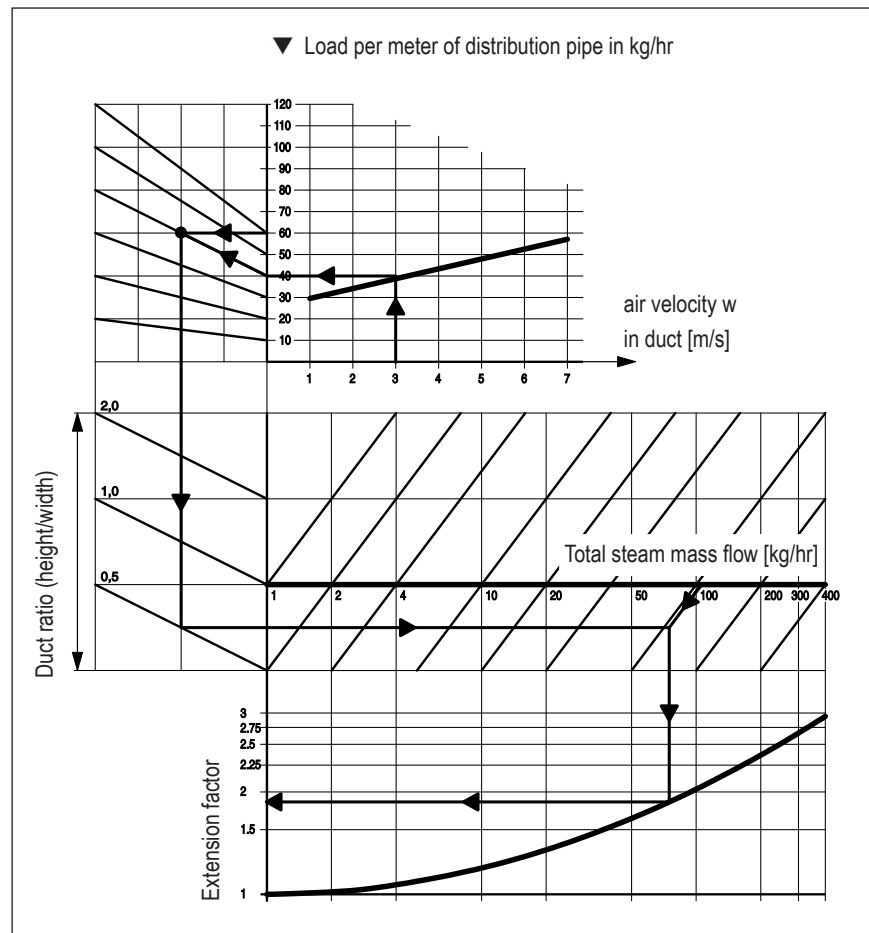

4.4 Installation in systems or ducts

Note: Detailed information on the installation is found in the separate “Condair Esco Installation Instructions”.

In principle, when you purchase the steam humidification system Condair Esco, we **guarantee a drop-free** humidification. An oversupply, however, from the humidifier, a clogged secondary condensate drain, or a malfunctioning controller or control valve are all it takes to feed water or a water/steam mixture into the steam distribution pipe. It will always be an advantage, therefore, to **protect** your system from **water damage** by installing either a **sealed section of duct** or a **drip pan** with drain.

To allow operational checks and **inspections of the humidification section**, at any time, we recommend to install an **inspection cover, inspection glass** or a **service opening** past the distribution pipe.

Important: The humidifiers have to be mounted in a horizontal way.

Procedure:

– Type DR73

Systems **without** ground clearance (**A-type**):

1. Provide openings (round holes) in duct (see chap. 4.6.1).
2. From the duct side, slide the main distribution pipe through the prepared openings.

Systems **with** ground clearance (**B-type**):

1. Provide a round hole in the duct bottom for each distribution pipe.
2. Attach the main distribution pipe with fixing plates.

Continued procedure for all unit types DR73

3. Mount the connection unit with connecting flange to the side of the duct (do not damage O-rings).
4. Carefully (without damaging O-rings) insert the clean steam distribution pipes into the sleeves of the main distribution pipe. To improve sliding, slightly moisten O-rings with water. **Never use oil or grease.**
Adjust the distribution pipes in such a manner that the steam nozzles are faced crosswise to the air flow.
5. Use the bolts to secure the distribution pipes.
6. Install the steam and condensate connections. Make sure that the condensate line has a down slope of approx. 0.5 - 1% .

– **Type DL40**

1. Provide openings (round holes) in duct.
2. From the duct side, slide the steam distribution pipe through the prepared openings. Make sure not to damage the steam pipe ends.
3. Mount the connection unit with connecting flange to the side of the duct. Make sure not to damage O-rings. To improve sliding, slightly moisten O-rings with water. **Never use oil or grease.**
4. Secure the distribution pipe with the bolt.
5. Install the steam and condensate connections. Make sure that the condensate line has a down slope of approx. 0.5 - 1%.

4.5 Dimension diagrams

4.5.1 Steam connection unit

Esco 10, 20 and 30

4.5.2 Rotary actuator

CA150A, CA150A-S and CA75

Steam connection unit		
	Esco 10	Esco 10
Rotary actuator	CA75	CA150A/ CA150A-S
A	417	424
B	159	159
C	121	121
D	85	85
E	74	74
F	81	81
G	205	205
H	143.5	143.5
I	132	132
K	116	182
L (Flange)	DN32/PN16	
M	66	98
N	125	125
O	210	210

all dimensions in mm

Steam connection unit		
	Esco 20	Esco 30
Rotary actuator	CA150A/ CA150A-S	CA150A/ CA150A-S
A	514	619
B	214	254
C	157	223
D	113.5	154
E	100	100
F	112	148
G	236	272
H	189	261
I	172	195
K	182	182
L (Flange)	DN50/PN16	DN80/PN16
M	98	98
N	132	187
O	315	350

all dimensions in mm

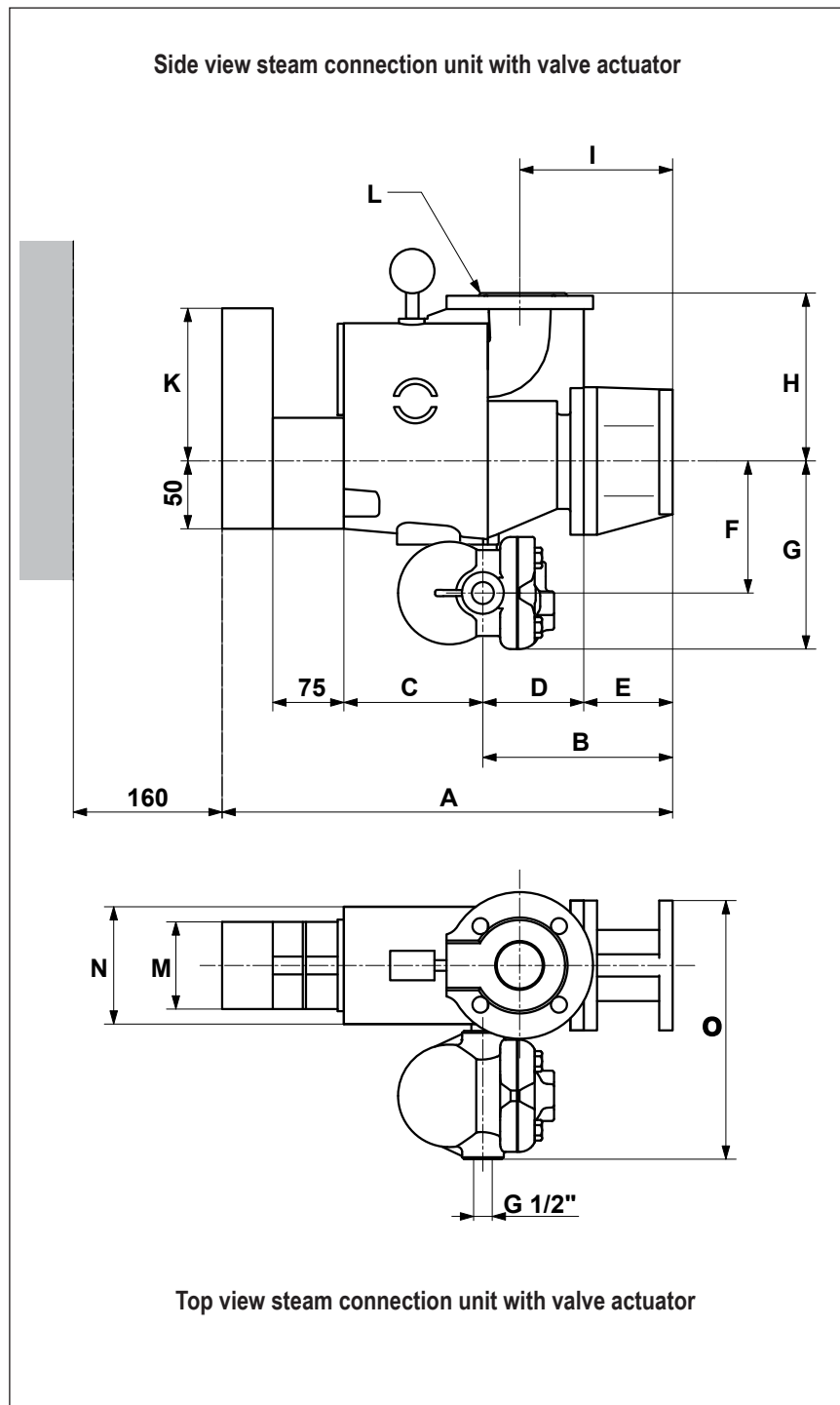

4.5.3 Pneumatic actuator P10

Condair Esco 5

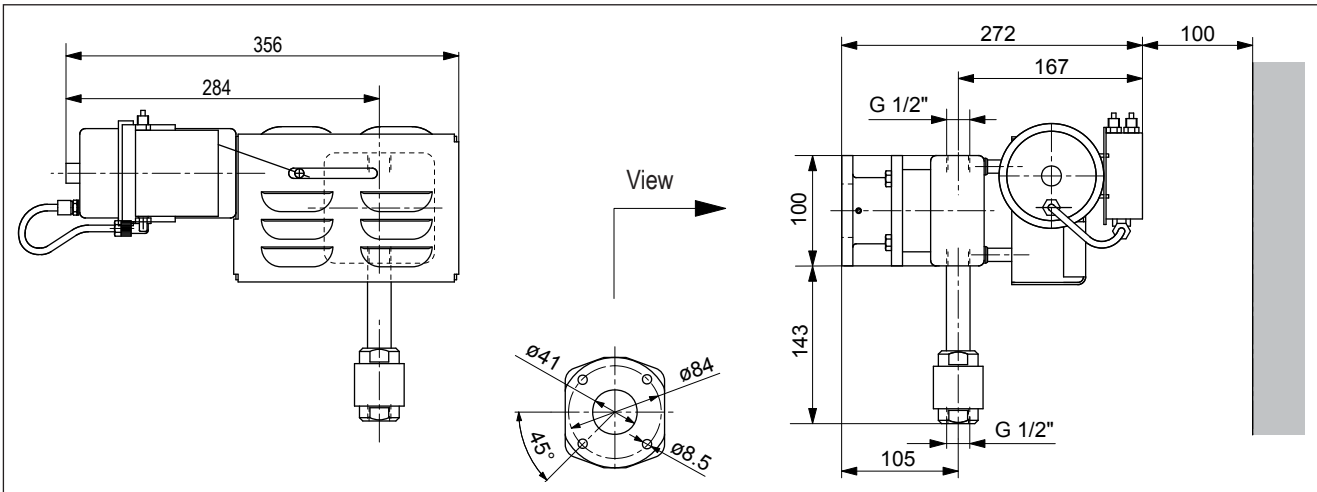

Condair Esco 10

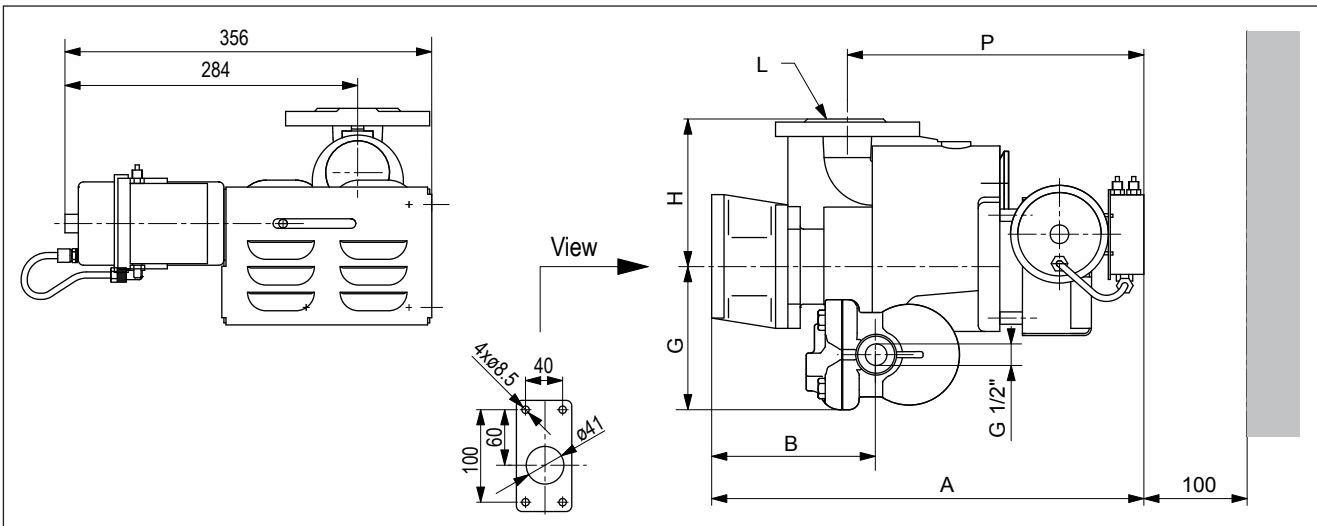

Condair Esco 20 and Condair Esco 30

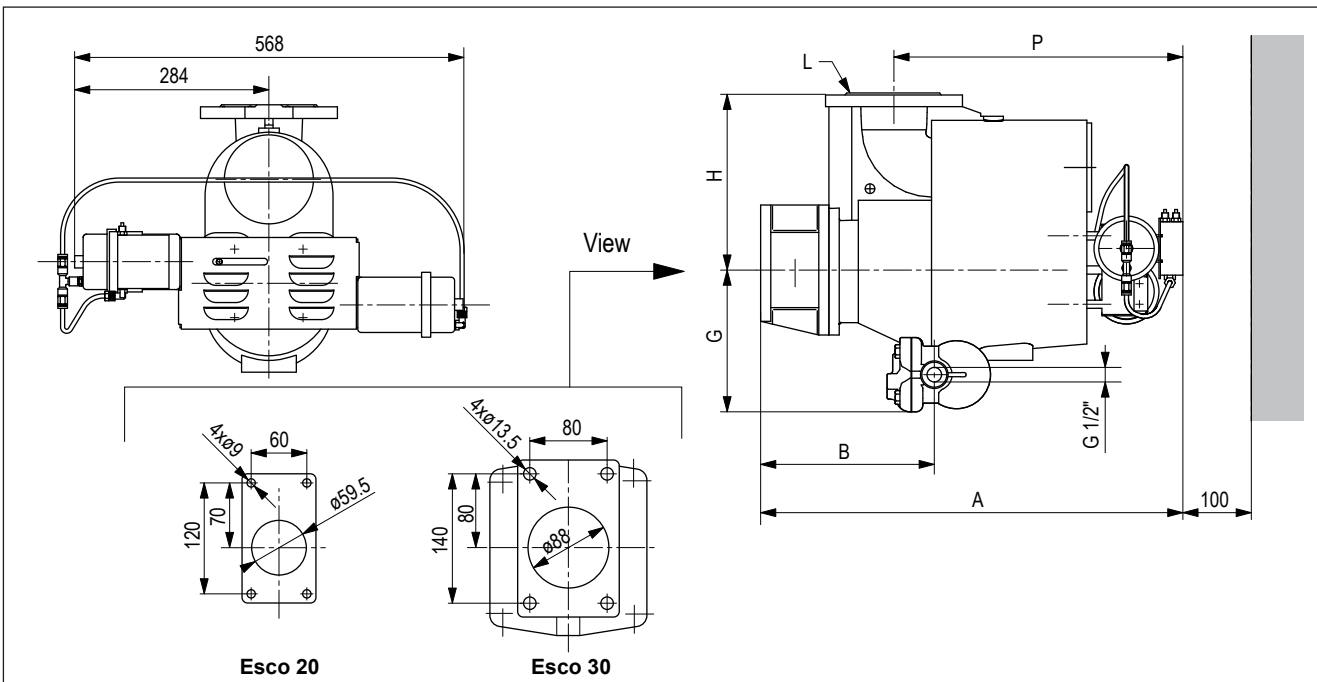

Steam connection unit Esco 10, Esco 20 and Esco 30
with pneumatic actuator

	Esco 10	Esco 20	Esco 30
P	288	338	422
B	159	214	254
L	DN32/PN16	DN50/PN16	DN80/PN16
G	205	236	272
H	143.5	189	261
A	420	510	617

all dimensions in mm

4.6 Dimensions diagrams for installation

4.6.1 Type DR73

Types A • Side view • Template

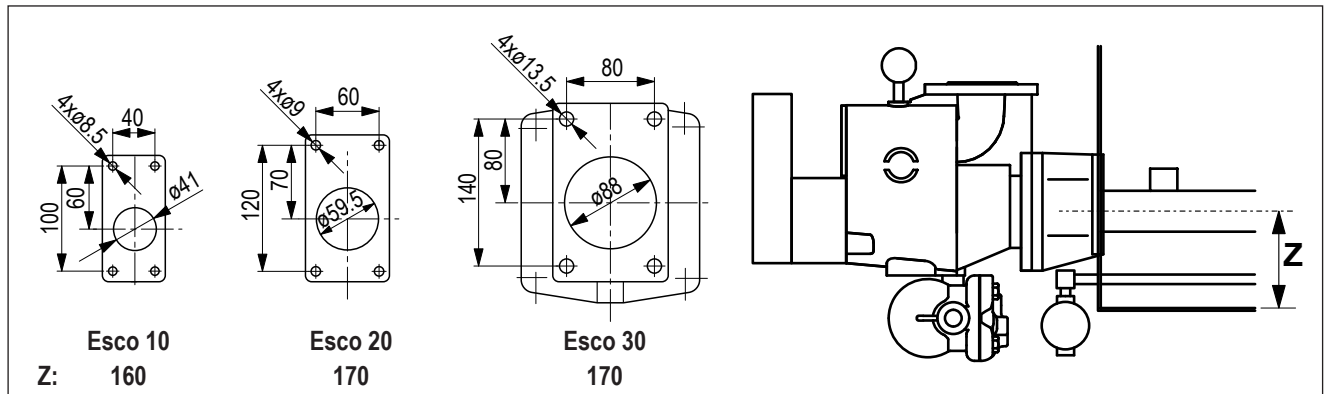

Type B • Side view • Template

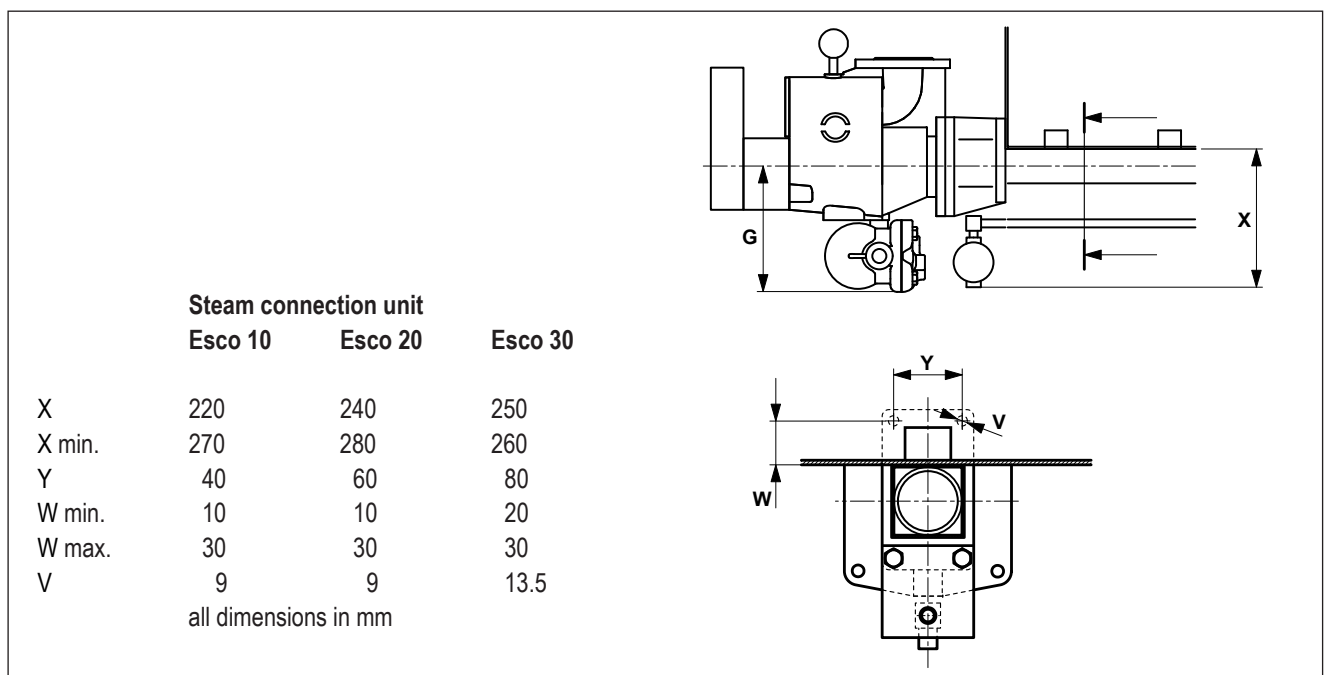

Detailed dimensions for steam distribution pipes DR73 can be requested following order confirmation.

4.6.2 Type DL40

- Position of the steam nozzles
- Coupling piece for multiple piping

The manufacturer recommends, mostly for uninsulated ducts and AHU's, to insulate the multiple couplings on site, or to install a silencer inside the duct, in order to reduce any noise that might occur.

Note: A special collector with built-in silencer is available from your Condair distributor on request.

Pipe length	X	Y
230 - 380 mm	80 mm	60 mm
580 - 1180 mm	110 mm	90 mm
1480-3880 mm	150 mm	130 mm

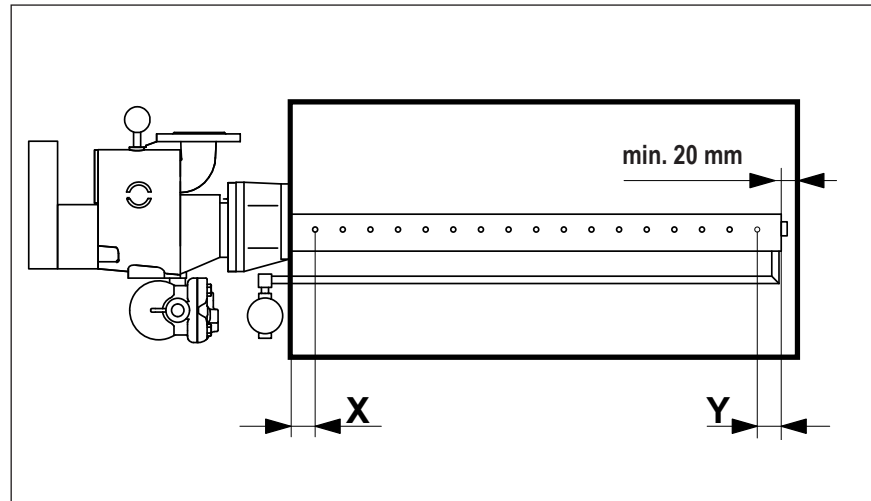

Dimensions for multiple piping

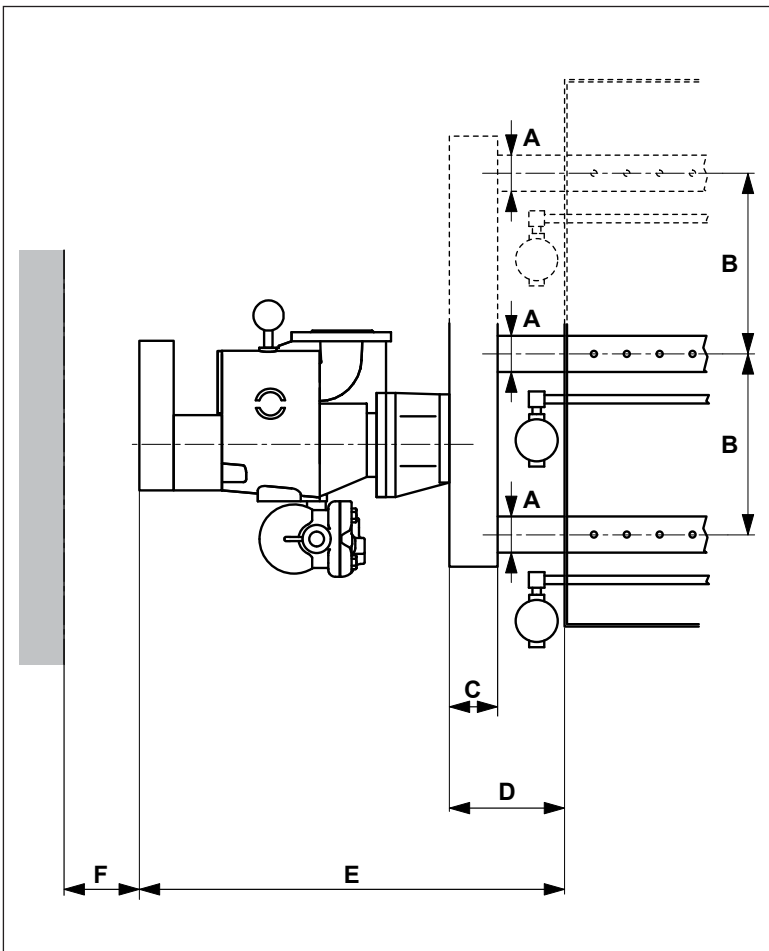

	Esco 10	Esco 10	Esco 20
	CA75	CA150A	
A	$\varnothing = 1 \frac{1}{4}'' (\varnothing=42)$		
B	300/600/900		
C	60/80/100	80/100/120	
D	135/155/175	155/175/195	
E	604/624/644	574/594/614	679/699/719
F	160	160	

all dimensions in mm

Side view • Template

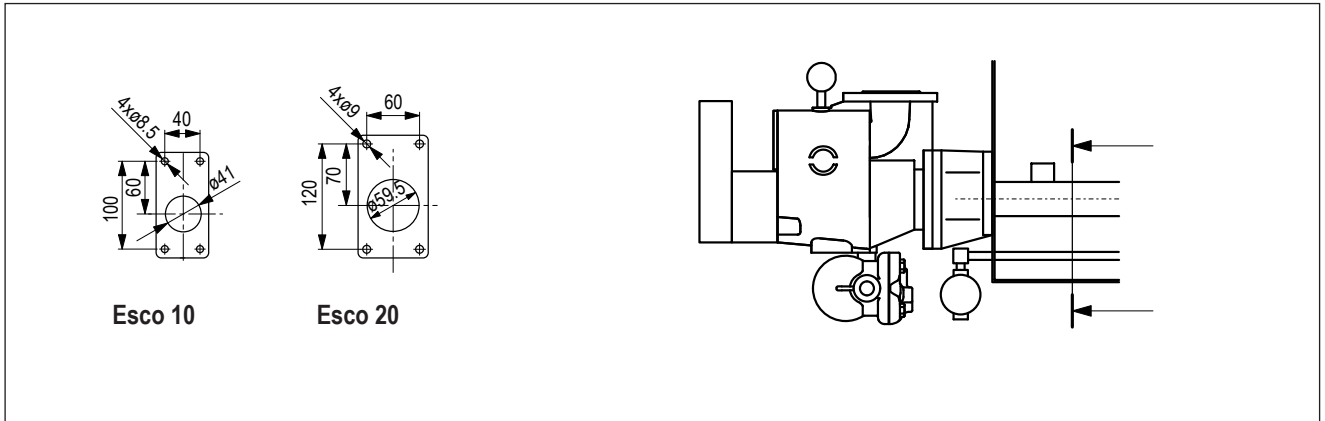

Installation for **single piping**

Installation for **dual piping**

Installation for **triple piping**

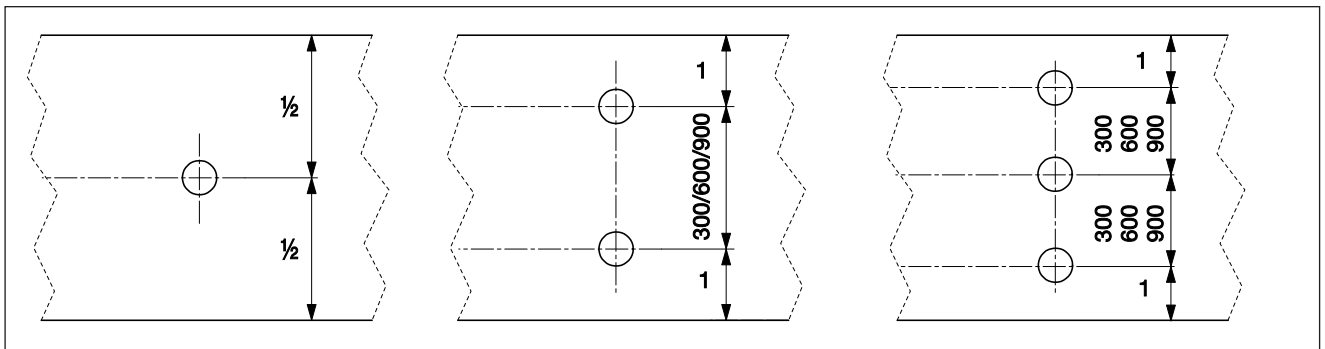

1 = min. 200 mm

Distance to upstream obstacle for ...

Upwind steam discharge:

Downwind steam discharge:

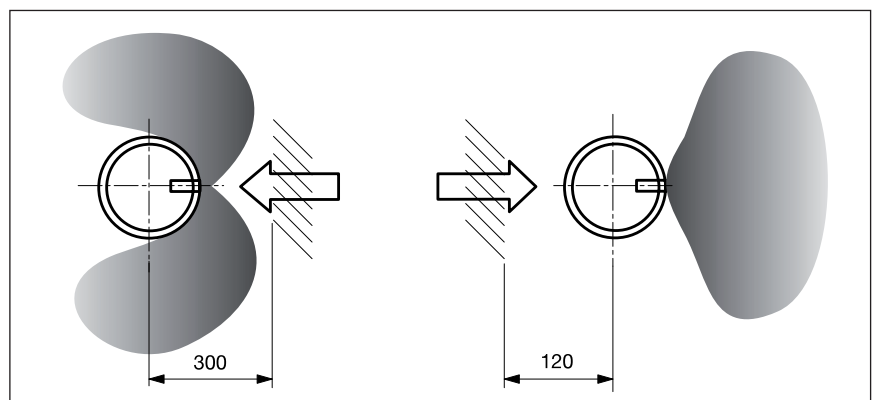

4.7 Connection diagrams for actuators

4.7.1 Electric rotary actuator CA150A and CA150A S

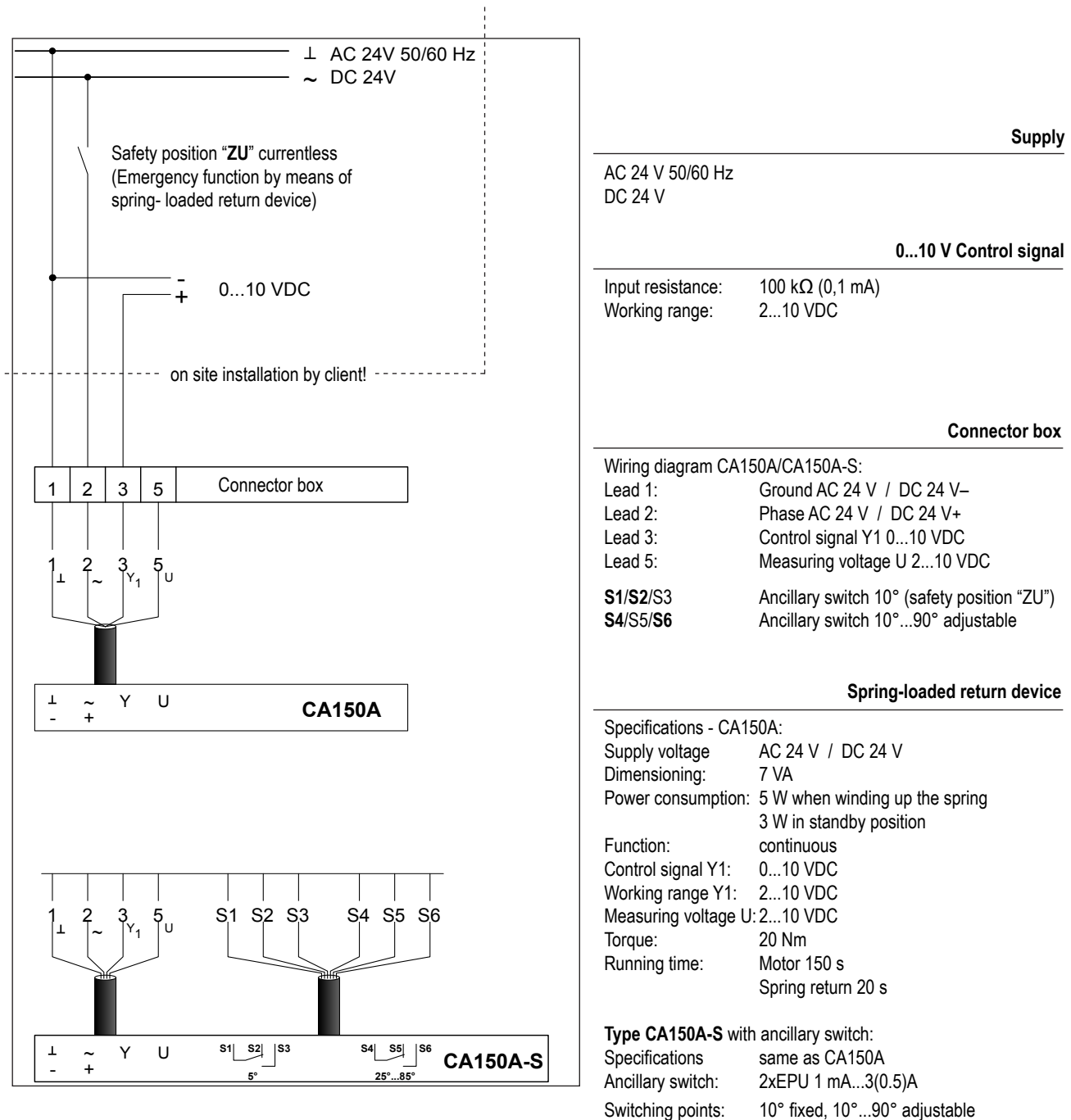

Caution: This is a functional diagram. The installation has to be carried out in accordance with local regulations. To prevent malfunction of the valve, **all electrical connections** of the rotary actuators must be properly wired to the connector box.

Note: The regulating range of the electric rotary control valve actuators starts at a control signal of 2 VDC. However, because the ceramic rotary disks overlap in their closed state (to ensure absolute tightness), the valve starts opening at a signal value of 3 VDC.

4.7.2 Electric rotary actuator CA75

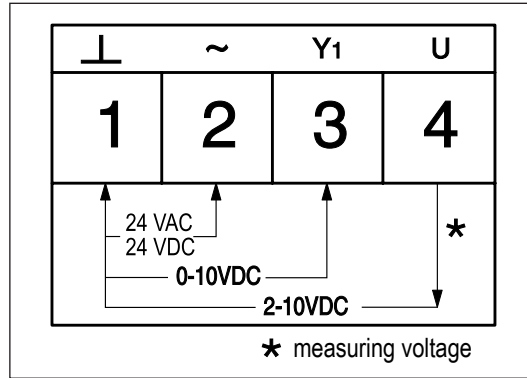

4.7.3 Positioner XSP 31 for pneumatic actuator P10

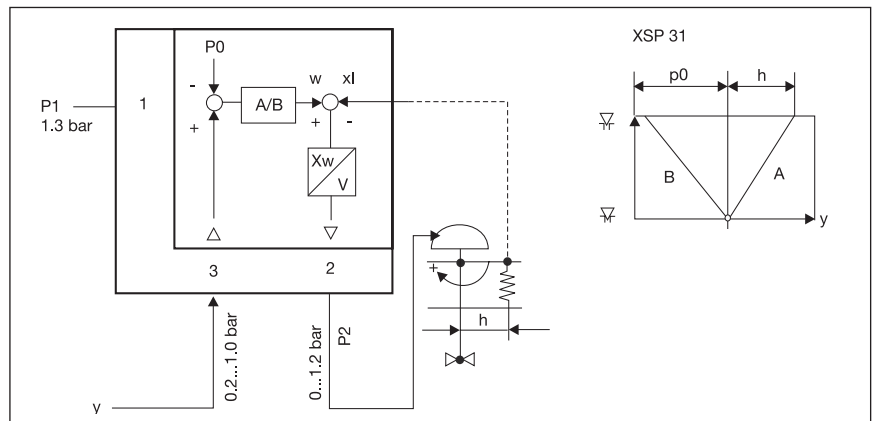

5 Hints for the heating engineer

5.1 Connecting the steam supply pipe

The supply pipe should be connected to the top of a perfectly drained main steam pipe and run with a down gradient to the steam humidifier. A shut-off valve (provided by customer) is installed preceding the humidifier. A steam pressure gauge (manometer) may also be provided.

Longer steam supply lines require appropriate draining!

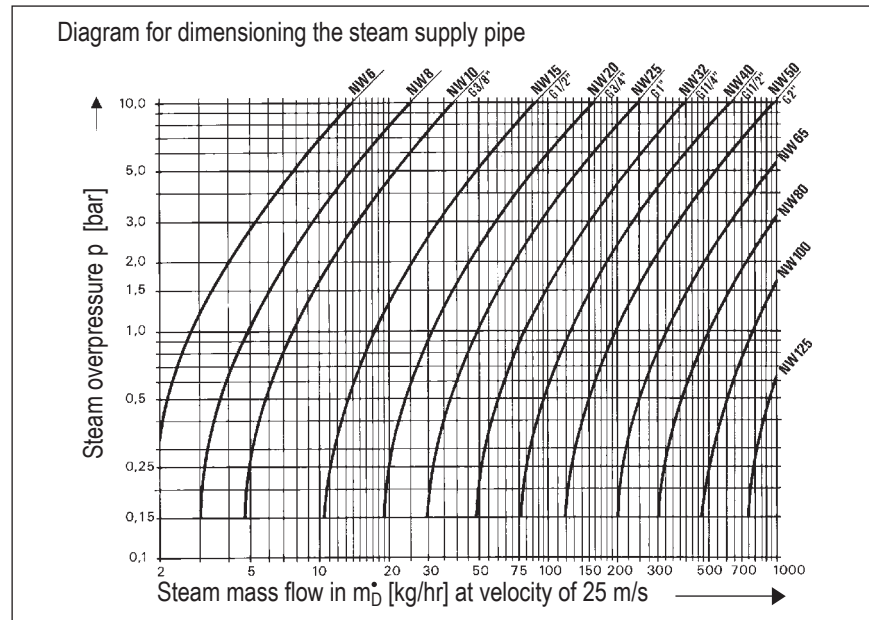

5.2 Installing the steam pipes

Insulation:



Always insulate steam pipes to prevent condensation.

Down gradient:



Always install steam pipes with a **down gradient in the flow direction**.

Steam tapping pipes:

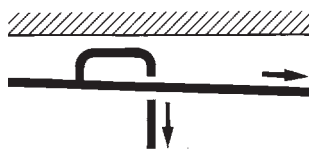

Always tap steam **from the top** of the pipe.

Suspension



Space steam pipe **attachments evenly**. Steam pipes must be installed **without any restrictions**. Use compensators or loops to allow for pipe expansion.

Ascending pipes

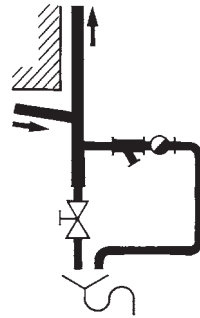

Always drain **ascending pipes at the lowest point**..

Key:

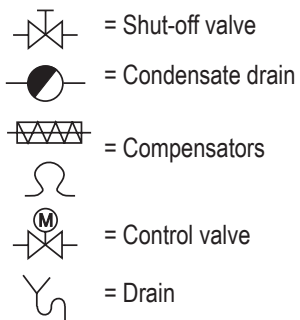

Deviations

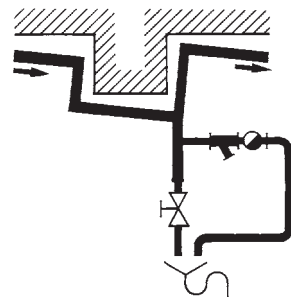

Always **drain by-passes**.

Control valves

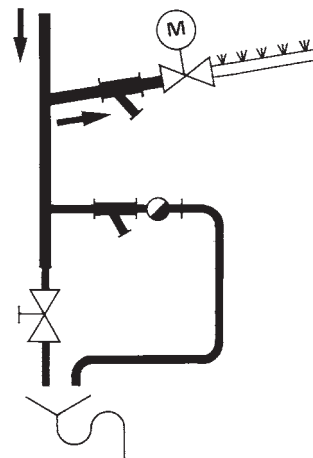

Always **drain control valves on the primary side**.

Installation examples

1. Short ascending pipes

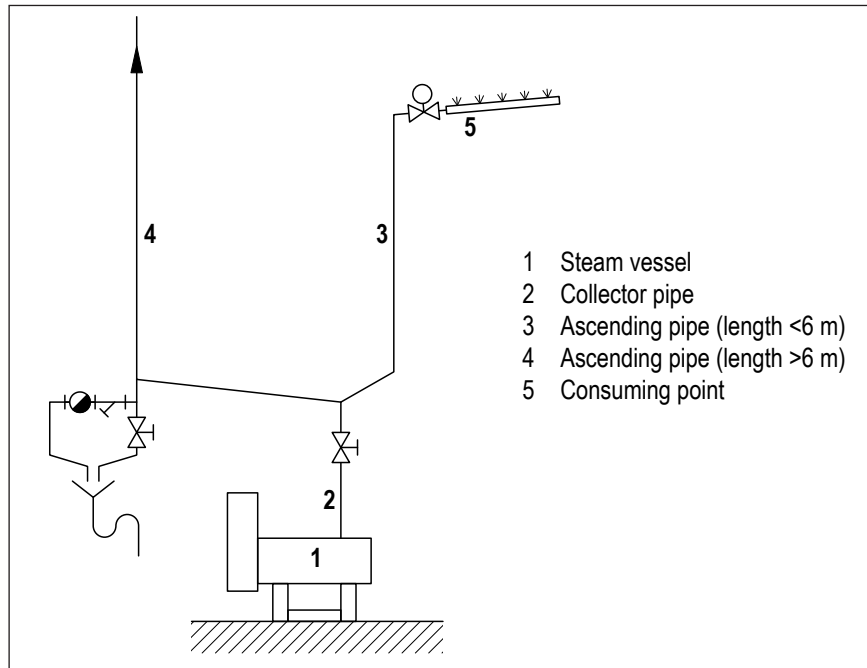

The collector pipe (2) from or to the steam vessel must be oversized by one nominal width unit!

Short ascending pipes up to 6 m max. (3) without transversal piping may be drained in backward direction towards the steam vessel (against the flow direction of the steam in this exceptional case).

Ascending pipes longer than 6 m (4) must be drained at their lowest point.

All supply lines to the humidifier at the customer's facility require appropriate draining at their lowest point.

2. General example

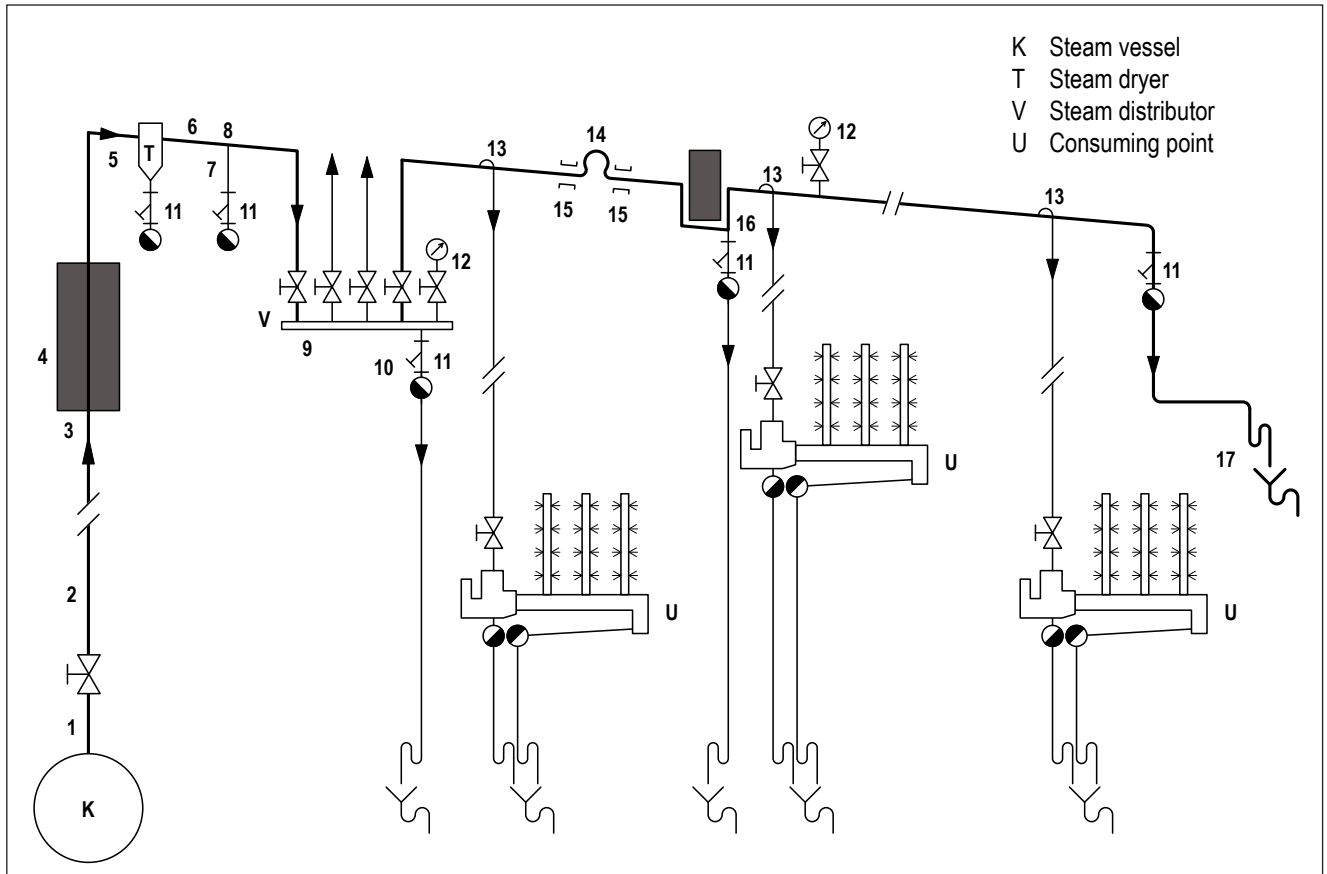

Checklist for the expert

- 1 Slowly open stop valve of steam collector line
- 2 Steam line: saturated steam at about 25 m/s
- 3 Insulation: 30...100 mm
- 4 Supports and fittings have to be insulated.
- 5 Install steam dryer (wet steam erodes the pipes)
- 6 Install lines at a downslope of 1:100 in flow direction
- 7 Use T-pieces for drains
- 8 Provide a drain every 20 to 40 m
- 9 Design the steam distributor as large as possible
- 10 The steam distributor requires a drain
- 11 Install a dirt pan to improve operational reliability
- 12 Install a pressure gauge for monitoring the steam pressure
- 13 Tapping of steam must always take place on the upper side of the steam line
- 14 Provide compensators for line expansion
- 15 Design an appropriate array of sliding and fixed points
- 16 Install drains at the lowest point of all steam lines
- 17 Provide a drain at the end of the steam line

Before commissioning: thoroughly rinse the entire system, open valves and connectors, clean, and blow out dirt at the lowest points of the line.

5.3 Schematic diagram

When Z is larger than 5 m, the pipe must be drained.

P = primary condensate drain:

The primary condensate can be drained, even against pressure, via built-in condensate drain. The back pressure must not exceed 50 % of the primary steam pressure.

S = secondary condensate drain:

The secondary condensate must be able to flow without any restrictions.

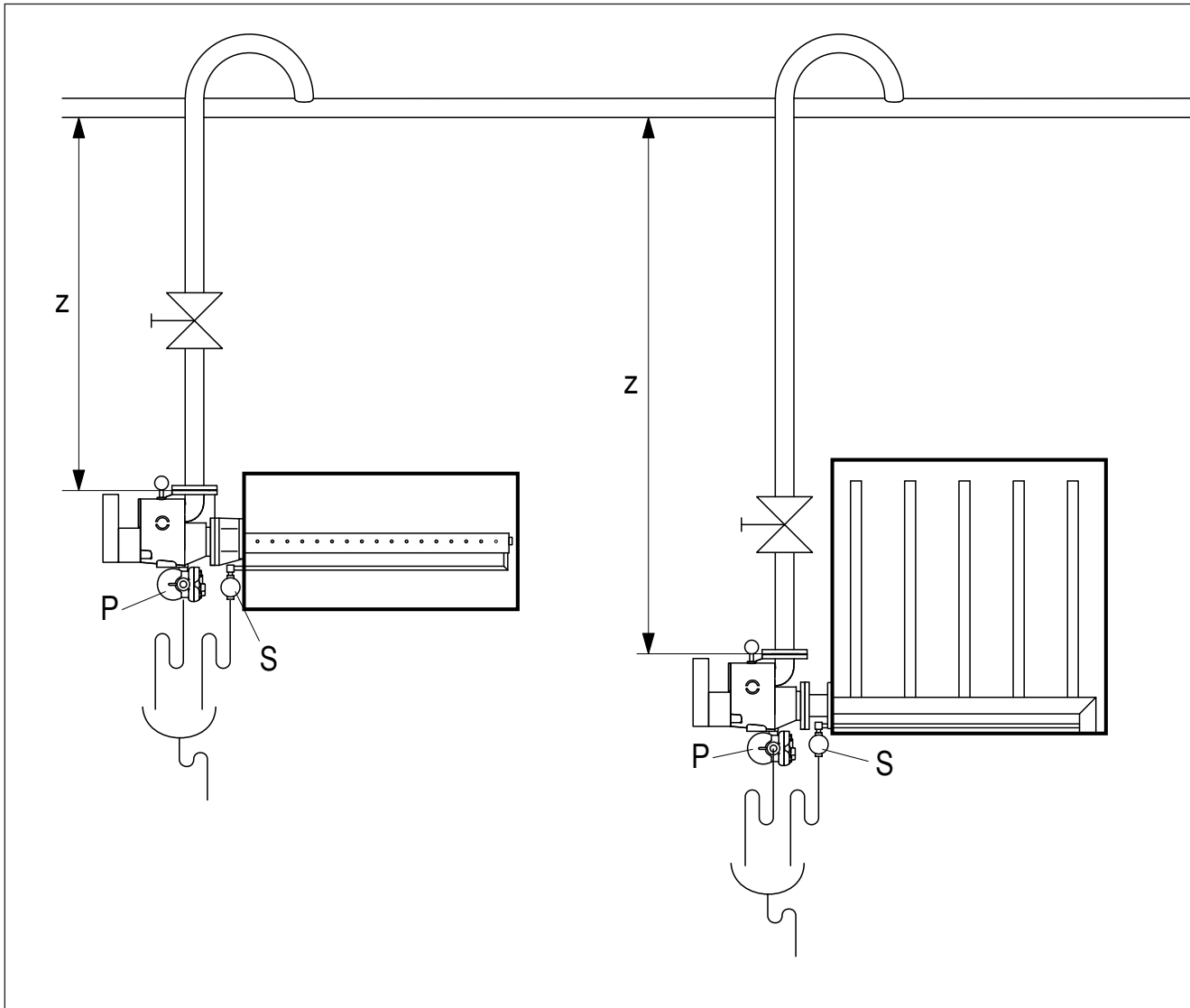

Primary and secondary condensate must be drained separately (unequal pressure).

5.4 Connections to be prepared by customer

Steam distribution pipes, type DR73 and DL40 can be connected to steam boilers, steam converters or existing steam supplies. The supply overpressure (live steam) should be as consistent as possible and be between 0.2 and 4.0 bar. Steam supply and condensate pipes are to be installed using suitable material. All gaskets, sealing material, threaded connections, and insulating material must be able to withstand temperatures of up to 152 °C, depending on the pressure. A shut-off valve is to be installed in the steam supply pipe.

The humidifier steam supply pipe is to be connected always to the top of a main supply pipe or steam generator with large steam volume. Installations of steam and condensate networks are to incorporate latest technical advances. Attention is to be paid to assure complete drainage during full capacity, less than full capacity and standstill.

Steam supply pipes, to be installed by the customer, must be connected to the Esco connection unit. Optimally arranged, it combines strainer, separation chamber, control valve and manometer (optional). This arrangement ensures contamination-free, dried steam at the inlet side of the control valve, which is thus protected from erosion. Condensate, accumulating from the steam supply pipe and the connection unit, is continually drained prior to reaching the control valve.

All condensate pipes, to be installed by the customer, are directly connected to the condensate drains and, with a slight down gradient (0.5-1 %), routed via siphon (steam trap) to a funnel or floor drain.

One steam connection, two condensate pipes, and the simple installation procedure, result in minimal installation costs at a maximum steam humidification quality. To avoid drainage problems, caused by a high steam volume or valve admission pressure, the condensate from the primary and secondary steam traps must be drained separately. **This means, the two condensate drain pipes must not be merged before the funnel.**

Post-vaporization: Upon draining of the conduit system through the condensate drains, post-vaporization may occur at the end of the condensate line which can be recognized by a continuous steam plume. Post-vaporization occurs when the condensate pressure drops to the ambient pressure, and by the large gradient between the condensate temperature and the ambient temperature. Post-vaporization is normal and should not be confused with steam loss caused by problems in the condensate drain.

Caution! In closed locations the steam caused by post-vaporization may have some undesired side effects. In such cases post-vaporization must be suppressed by taking appropriate measures (siphons, cooling section, etc.).

6 Initial start-up

1. Make sure the steam supply and condensate pipes are properly connected.
2. Slowly open the shut-off valve, examine the entire steam supply pipe to the control valve for leaks, and monitor the manometer for the required steam pressure. Retighten leaking connections, and close the shut-off valve again.
3. Insulate the entire steam supply pipe with appropriately heat-resistant material.
4. To put the steam humidification system Condair Esco DR73 and DL40 as well as the attached valve actuator into operation, refer to the guidelines provided by the control and installation firms. Operation may be initiated only by an appropriately trained control specialist or service technician.
5. Testing the system behaviour in case of voltage loss ⇒ The steam discharge from the steam distribution pipes must be interrupted. When using **actuators without emergency function**, the interruption of steam discharge from the pipes, in case of voltage loss, must be guaranteed **by some other on-site safety device**. Without this on-site safety device, steam discharge from the steam pipes cannot be interrupted. **The manufacturer cannot be held responsible for any water damages resulting from this.**

7 Maintenance

Immediately following the initial operation, all screwed connections must be checked for leaks and retightened if necessary. After the steam distribution system Condair Esco has been in operation for one to two weeks, the strainer in the connection unit must be cleaned.

The strainer must be cleaned whenever necessary.

The attached rotary control valve actuators CA75, CA150A and CA150A-S are maintenance-free. For other actuators, the operating and maintenance instructions of the appropriate supplier are applicable.

Primary and secondary condensate drains are maintenance-free. However, clogging can also occur within the connections or in the condensate network.

In case of problems with the condensate drainage, consult the troubleshooting guide.

The condition for a perfect functioning during a long time is:

Application of dry steam, which does not contain any mineral salt, such as chloride, sulphate, sulfide and ammonia. (see note VdTÜV 1453, edition 4/83; Editor: Union of the associations of technical observation e.V., Essen).

8 Trouble-shooting guide

Error or malfunction and possible cause

No steam is discharged from the distribution pipes

- Actuator mounted incorrectly
- Control or high-limit humidistat set too low
- Defective control line between humidistat, controller and rotary control valve actuator
- Defective or interrupted control line to safety devices (system interlock)
- High-limit humidistat placed in wrong location
- Ceramic rotary-disk control valve in closed position
- Defective rotary control valve actuator or Ceramic rotary-disk control valve is jammed
- Control voltage or pressure loss

Malfunctioning steam supply

- Shut off valve in steam supply pipe closed (Check manometer)
- Steam supply pipe clogged by dirt
- Safety shut off valve closed

Ceramic rotary-disk control valve is not closing, excessive humidification

- Actuator mounted incorrectly
- Humidistat defective or improperly set
- Defective controller
- Defective rotary control valve actuator (voltage available)
- Ceramic rotary-disk control valve is jammed
- Pressure spring has lost its resilience
- Loss of control voltage; actuator (without emergency function) does not close valve

Water is discharged from the steam distribution pipes

- Steam supply pipe not insulated
- Steam supply pipe not properly drained
- Steam supply pipe connected incorrectly to the main pipe (bottom or side instead of on top)
- Incorrect primary pressure resulting in incorrect secondary pressure after the valve ($p_2 > 0.15$ bar) or improperly dimensioned ceramic rotary-disk control valve
- Oversupplied or overstressed steam generator (water is forced along)
- Malfunctioning steam distribution pipe drainage (clogged or defective condensate drain)
- Excessive back pressure in condensate drain pipe (secondary condensate drained under pressure)
- Primary and secondary condensate drains are joined together
- Condensate line is routed too high (static back pressure)
- Main distribution pipe is not installed horizontally

9 Vaporisation / condensation

9.1 Terminology and definitions

- **Vaporisation**

Vaporisation is understood to be the transition of a liquid into the gaseous stage upon reaching the substance's boiling point. The onset of the boiling process depends on the following parameters:

- Steam pressure of the liquid
- Ambient pressure
- Temperature
- Substance

- **Saturated vapour pressure**

The saturated vapour pressure is that value, which is characterised by the balance between the ambient pressure and the vapour pressure of a liquid.

Once the equilibrium is reached, vaporisation of the liquid takes place; this is called saturated steam.

The steam pressure of a liquid is temperature-dependent so that the pressure equilibrium, at which evaporation begins, is characterised for each substance by a temperature pressure curve. This curve is called saturated steam curve.

- **Saturated steam**

Steam that reaches the saturated steam pressure but is not separated from the liquid phase, interacts with the liquid, i.e. the amount of water that vaporises equals the amount of steam that condenses. Steam, in such an interactive state, is called saturated steam.

Most important characteristic:

Saturated steam is not compressible (a part of it would condense in the process).

- **Wet steam**

When saturated steam cools down (e.g. by heat loss) part of it condenses, and the share of water droplets in the steam increases. This is called wet steam.

- **Superheated steam**

Steam, which is separated from the liquid and heated up, is called superheated steam.

Most important characteristic:

Superheated steam is compressible.

- **Vaporisation heat**

Vaporisation heat equals the transformation energy required to vaporise a liquid. In order to compare different substances, the specific vaporisation heat (transformation energy per measuring unit kJ/kg) is observed.

From the diagram for water (see below) it can be seen, that the temperature (at sea level) remains constant at a 100 °C. Any additional heat is used for vaporising; this heat is called vaporisation heat.

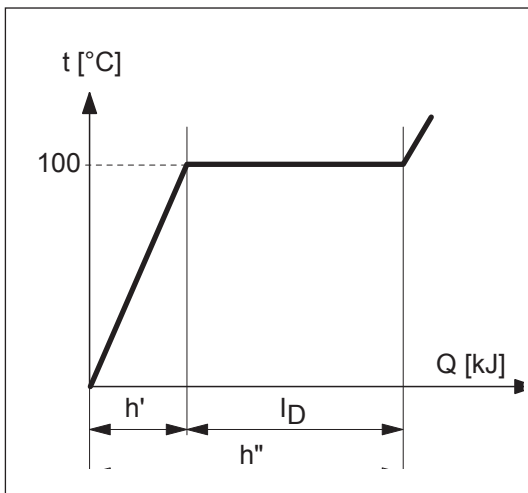

Key:

- Q = Thermal energy
- t = Temperature
- h' = Heat content water
- h'' = Heat content steam
- l_D = Vaporisation heat

- **Enthalpy**

Enthalpy equals the latent energy of a substance.

In steam, the enthalpy equals the heat content, which is the heat required for vaporisation plus the latent energy which already existed before the vaporisation.

Enthalpy is expressed per measuring unit (kJ/kg)

- **Condensation**

Condensation is understood to be the transition of saturated steam into the liquid state.

Condensation occurs when a certain pressure or temperature change takes place. Gas does not condense outside the saturated steam range (e.g. superheated steam cannot be condensed by a pressure increase).

- **Condensate**

Condensate equals water which originates from condensed steam. The temperature of the condensate is the same as that of the steam.

- **Condensation heat**

Energy, which was used to vaporise, is released again when condensation takes place; it is referred to as condensation heat. Condensation heat is utilised in many instances, e.g. in dehydration processes.

10 Work sheet DR73 / DL40

		Work sheet	DR73		DL40	
1	Position					
2	System designation					
3	Amount (humidifier)	pcs.				
4	max. humidification capacity mD	kg/hr				
5	Steam overpressure (valve admission pressure) p1	bar				
6	Humidity before humidification x1	g/kg				
7	Humidity after humidification x2	g/kg				
8	Humidity increase Δx	g/kg				
9	Inner duct width a / wall thickness	mm	/	/	/	/
10	Inner duct height b / wall thickness	mm	/	/	/	/
11	Installation in (G = Unit / K = Duct)					
12	Air volume flow	m³/hr				
13	Air mass flow	kg/hr				
14	min. air velocity	m/s				
15	min. air temperature t1 (before distributor pipe)	°C				
16	Existing humidification distance	Downstram obstacle	m/...	/	/	/
17	Actual humidification distance B	m				
18	Steam distributor pipe	Type				
19	Number of steam distributor pipes	pcs.				
20	Steam connection unit	Esco				
21	Steam connection DN 32 / PN 16	NW				
22	Control valve (according to diagram)	Type				
23	Valve actuator	Type				
24	Options	Manometer	pcs.			
25		Dual coupling	Type	xxxxxxxx	xxxxxxxx	
26		Triple coupling	Type	xxxxxxxx	xxxxxxxx	
27		Mounting set for insulated ducts/AHU's	pcs.			
28						
29						
30						
31						
32						
33						
34						
35						
36						
37	Total price per system:					

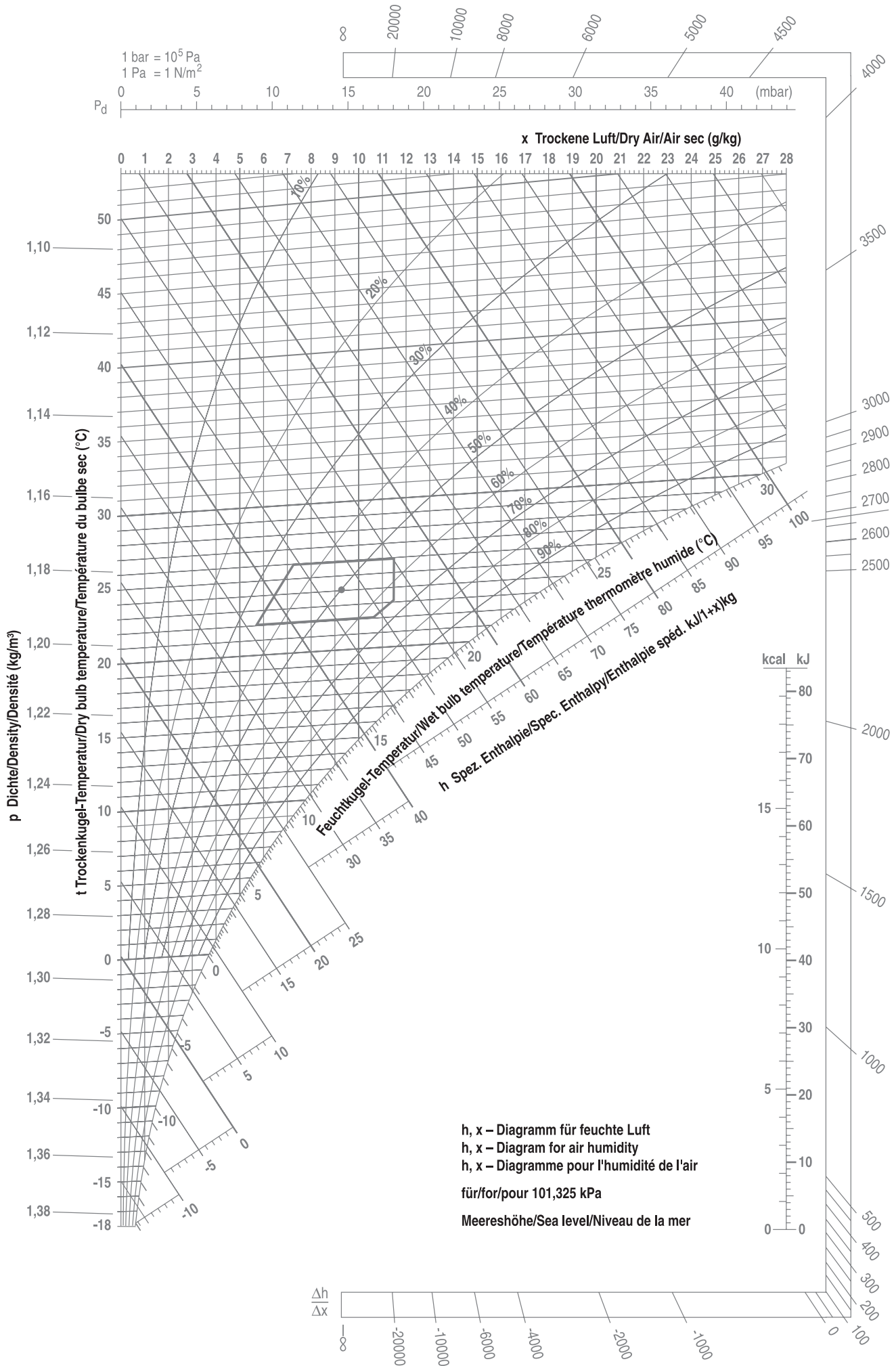

Notes

Notes



CONSULTING, SALES AND SERVICE:



JS Humidifiers plc
Artex Avenue, Rustington,
LITTLEHAMPTON, West Sussex
BN16 3LN (United Kingdom)
Phone +44 (0)1903 850 200, Fax +44 (0)1903 850 345
www.jshumidifiers.com, sales@jshumidifiers.com

Solutions for Indoor Climate



Reg.No. 40002-2

Manufacturer:
Walter Meier (Climate International) Ltd.
Talstr. 35-37, P.O. Box, CH-8808 Pfäffikon (Switzerland)
Phone +41 55 416 61 11, Fax +41 55 416 62 62
www.waltermeier.com, international.climate@waltermeier.com

**walter
meier**